

AEG

Instruction Book

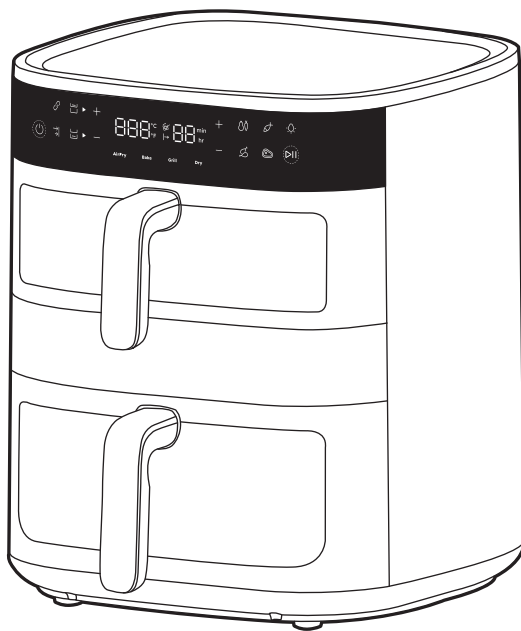

8000 Air Fryer Dual

General Overview

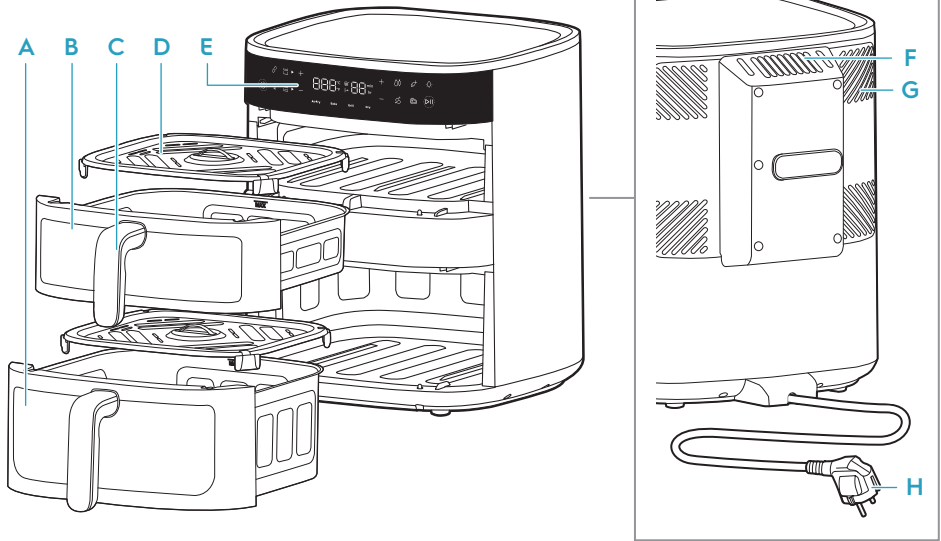

- | | | | |
|-----------------------------|------------------------|------------------------|-------------------------|
| A Bottom basket (7L) | C Basket handle | E Control panel | G Cooling system |
| B Top basket (4L) | D Grid | F Air outlet | H Main cord |

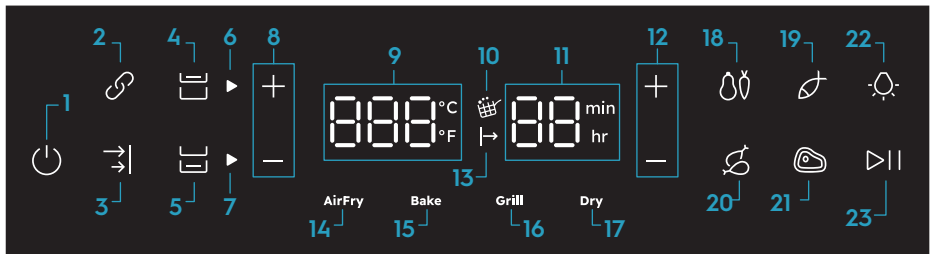

- | | | | |
|----------------------------|---|------------------------|-------------------|
| 1. On/Off | 8. Temperature control | 12. Time control | 18. Vegetables |
| 2. Link function | 9. Temperature indicator (40-200°C) | 13. Waiting to cooking | 19. Fish |
| 3. Sync End function | 10. Shake Reminder | 14. AirFry function | 20. Chicken |
| 4. Top basket control | 11. Time indicator (AirFry: 1-99min, Dehydrate: 1-5h) | 15. Bake function | 21. Steak |
| 5. Bottom basket control | | 16. Grill function | 22. Light control |
| 6. Top basket indicator | | 17. Dry function | 23. Play/Pause |
| 7. Bottom basket indicator | | | |

GB

BG

DE

ES

FR

GR

IT

PT

NL

CA

SE

FI

DK

NO

HU

AR

Before first use

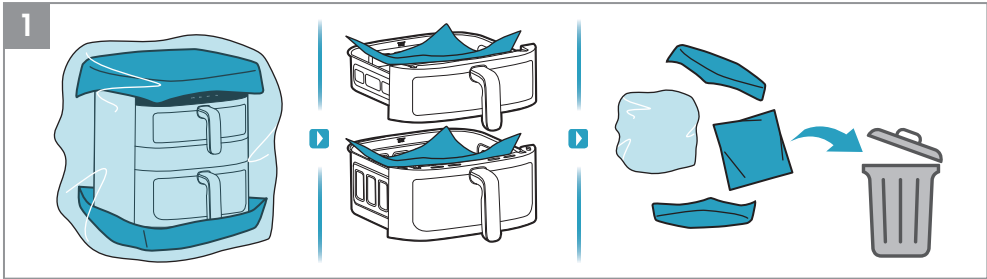

1. Remove all the packaging and protective material.

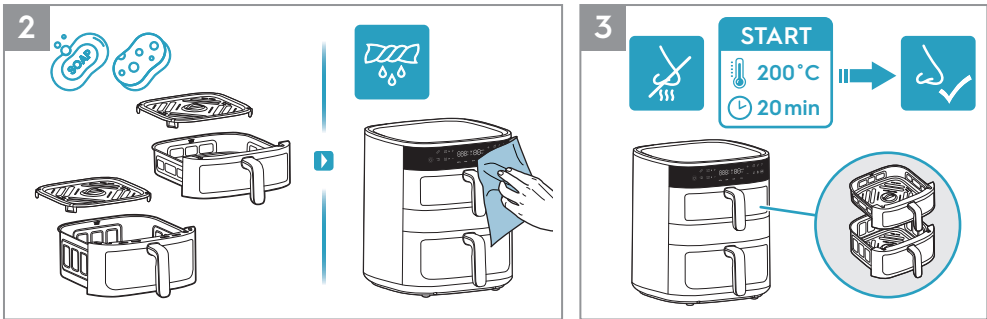

2. Clean the pan and grid with warm water and dish soap. Wipe inside and outside of the appliance with a soft cloth.
3. It is normal for a new unit to emit odors the first few times it is operated. Run the empty air fryer at 200°C for 20 minutes before first use to avoid that.

! Safety precautions

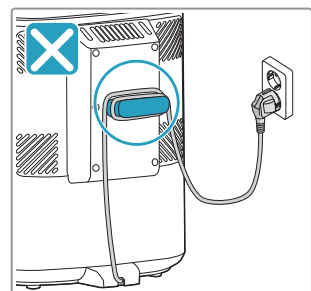
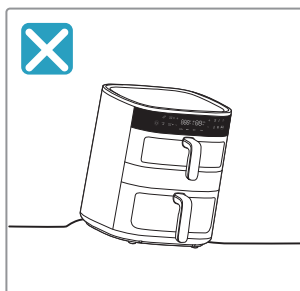
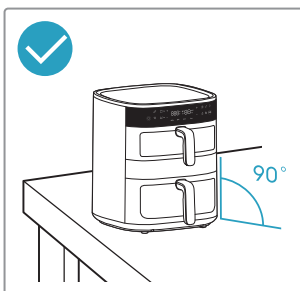
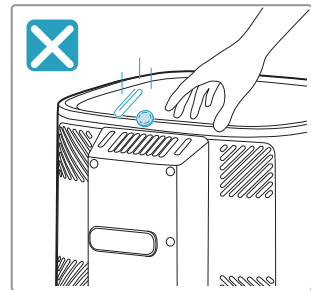
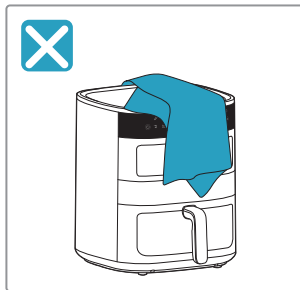
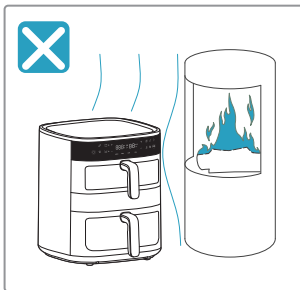

GB

BG

DE

ES

FR

GR

IT

PT

NL

CA

SE

FI



DK

NO





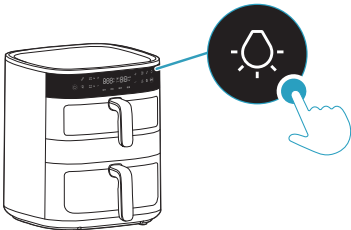
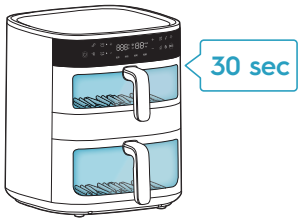

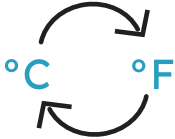



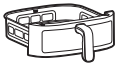
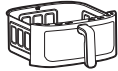

HU

AR

Lighting control & temperature scale conversion

 <p>Lighting control</p>		
<p>°C/°F</p> <p>Temperature scale conversion</p>		

Basket selection

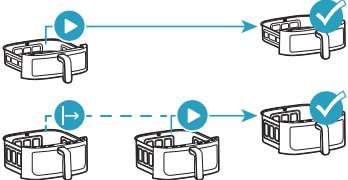
	 <p>4L</p>	 <p>7L</p>	
 <p>Top Basket</p>			
 <p>Bottom Basket</p>			
 <p>Link function</p>			
 <p>Sync end function</p>			

GB

BG

DE

ES

FR

GR

IT

PT

NL

CA

SE

FI















DK

NO

HU

AR

Pre-set Functions

 AirFry					
AirFry	180°C	15min	60~200°C	1~99min	
	170°C	10min	60~200°C	1~99min	
	140°C	15min	60~200°C	1~99min	
	180°C	30min	60~200°C	1~99min	
	200°C	10min	60~200°C	1~99min	
Bake	170°C	15min	60~200°C	1~99min	
Grill	200°C	5min	60~200°C	1~99min	
Dry	80°C	5h	40~80°C	1~5h	

Before Cooking

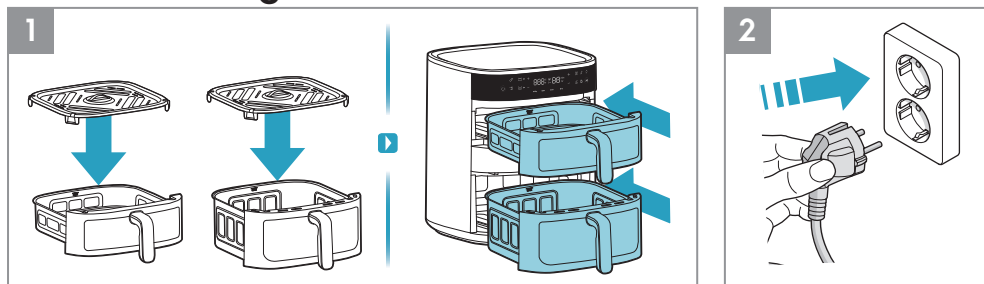

1. Before each cooking, please place the grid into the basket (the heat-resistant silicone foot pad of the grid does not need to be removed), and fully push the basket into the appliance.
2. Insert the power plug into the power outlet.

GB

BG

DE

ES

FR

GR

IT

PT

NL

CA

SE

FI

DK

NO

HU

AR

How to use - Single basket

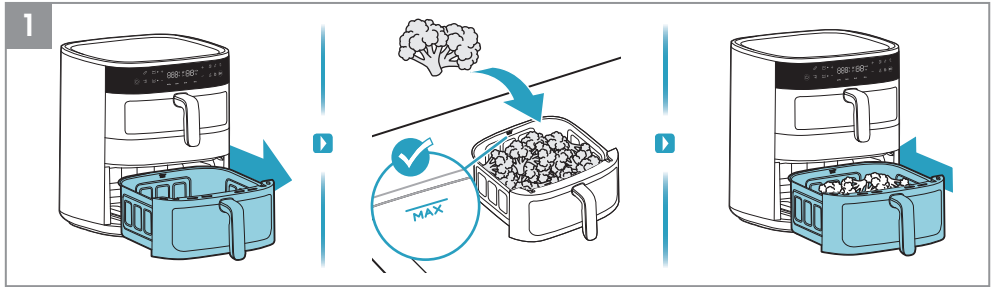

1. Pull out one basket and place it on a stable surface, put the food in the basket, observing the "MAX." capacity indication. Then push the basket with food completely back into the appliance.

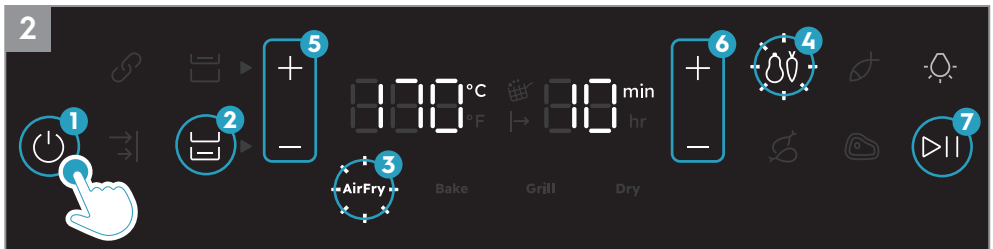

2. Press the On/Off button. First select the basket with food. Then select your desired cooking method, for example, Air Fry function. Adjust the time and temperature to your taste or select one of the pre-set recipes, for example, Vegetable. At last, press the Play/Pause button.

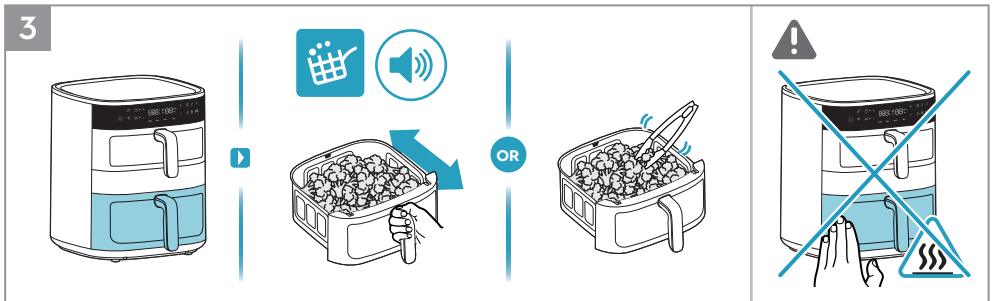

3. When the "Shake Reminder" icon lights up and beeps during the cooking process, use heat-resistant tools to flip the food once or carefully shake the food in the frying basket slightly.

- ⚠ **CAUTION:** Do not shake the frying basket vigorously to avoid food splashing and causing burns.
- ⚠ **CAUTION:** Be careful with hot surfaces when the appliance is in use.

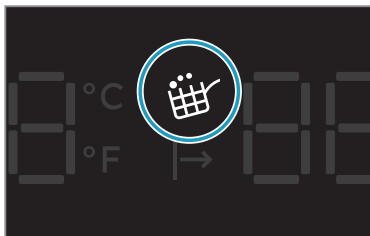

Shake Reminder

The "Shake Reminder" is activated during Air Fry function and the pre-sets recipes, such as vegetables, Fish, Chicken legs and Steak.

When it is time to shake or flip your food, the "Shake Reminder" icon will light up and blink for one minute, while a beep sound will repeat for three times.

The "Shake Reminder" is not mandatory, hence the cooking will continue as usual even if the food is not flipped or shaken.

GB
BG
DE
ES
FR
GR
IT
PT
NL
CA
SE
FI
DK
NO
HU
AR

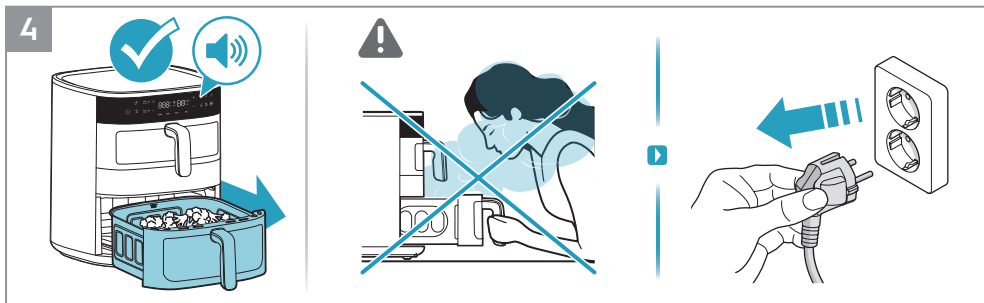

4. At the end of the cooking time, the appliance will issue a beep signal. Carefully remove the basket and place it on a heat-resistant surface. Unplug the appliance after using it.

⚠ CAUTION: Hot steam can come out of the basket when it is opened mid or at the end of cooking. Make sure your face, arms and hands are away from the steam when opening it.

How to use - Top + Bottom basket

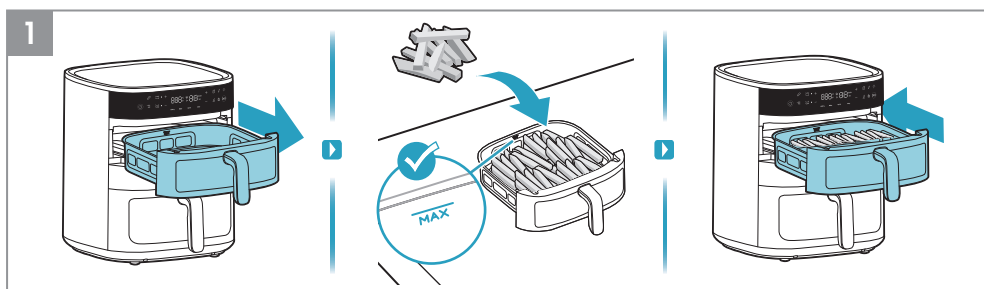

1. Firstly, pull out the top basket and put the food in the basket, for example, french fries.

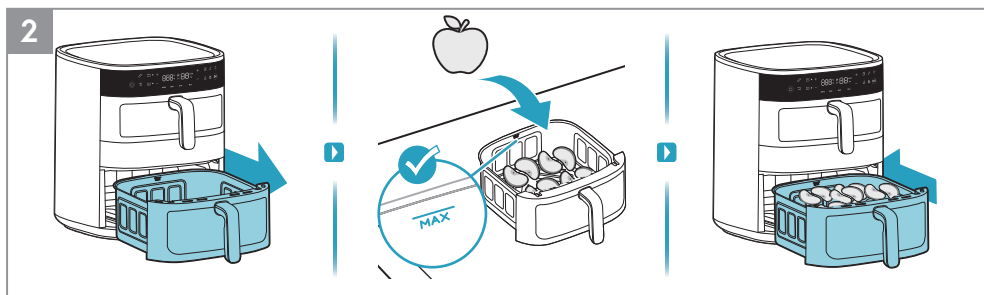

2. Secondly, pull out the bottom basket and put the food in the basket, for example, apple slices.



3. Press the On/Off button. First select the top basket. Then select your desired cooking method, for example, Air Fry function. Adjust the time and temperature to your taste or select one of the pre-set recipes, for example, Vegetable. At last, press the Play/Pause button.

GB

BG

DE

ES

FR

GR

IT

PT

NL

CA

SE

FI

DK

NO

HU

AR



4. Secondly, select the bottom basket. Then select your desired cooking method, for example, Dry function. Adjust the time and temperature to your taste. At last, press the Play/Pause button.

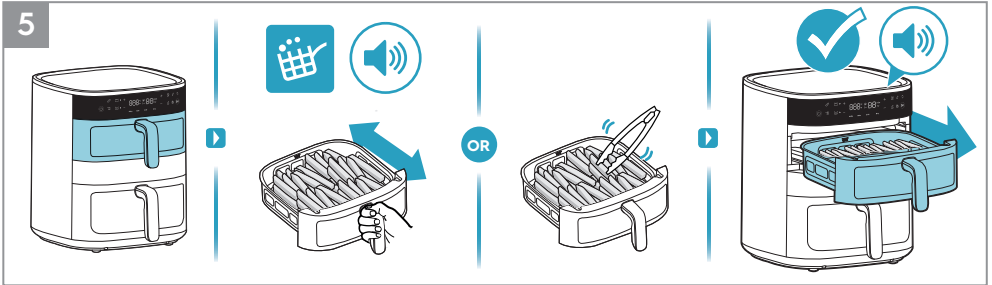

5. When the "Shake Reminder" icon lights up and beeps during the cooking process, use heat-resistant tools to flip the food once or carefully shake the food in the frying basket slightly. At the end of the top basket cooking time, the appliance will issue a beep signal.

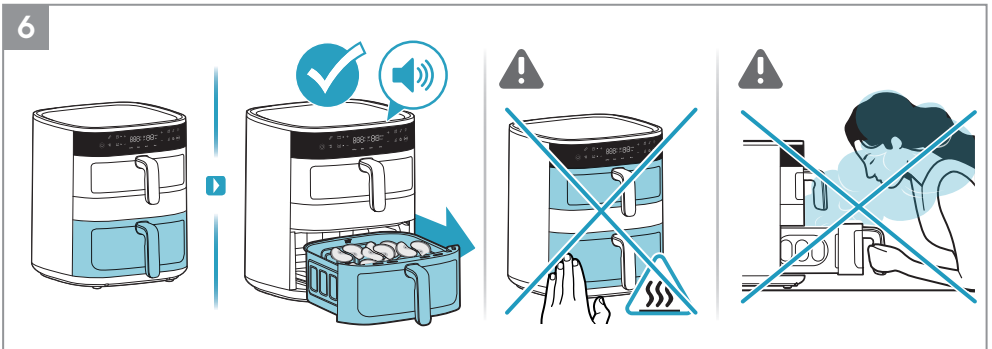

6. At the end of the bottom basket cooking time, the appliance will issue a beep signal.

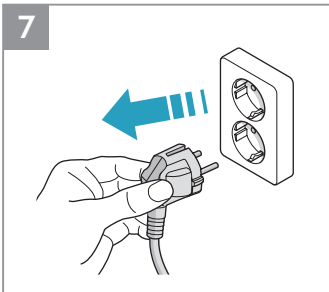

7. Unplug the appliance after using it.

GB

BG

DE

ES

FR

GR

IT

PT

NL

CA

SE

FI

DK

NO

HU

AR

How to use - Link function

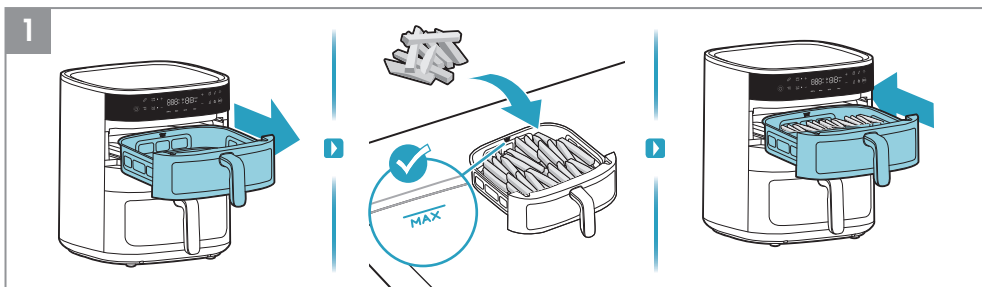

1. Firstly, pull out the top basket and put the food in the basket, for example, french fries.

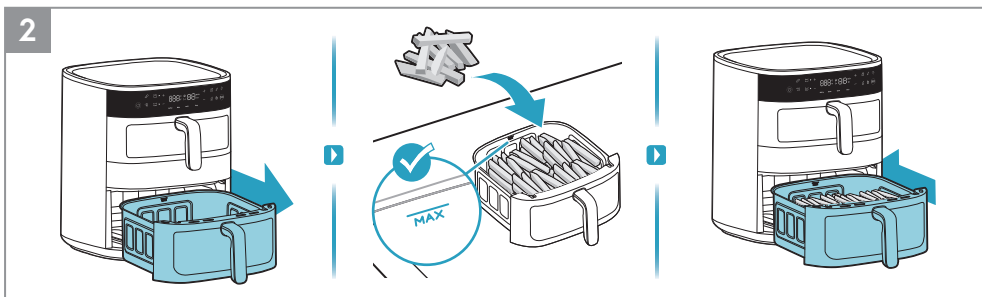

2. Secondly, pull out the bottom basket and put the food in the basket, for example, french fries.



3. Press the On/Off button. First select the link function. Then select your desired cooking method, for example, Air Fry function. Adjust the time and temperature to your taste or select one of the pre-set recipes. At last, press the Play/Pause button.

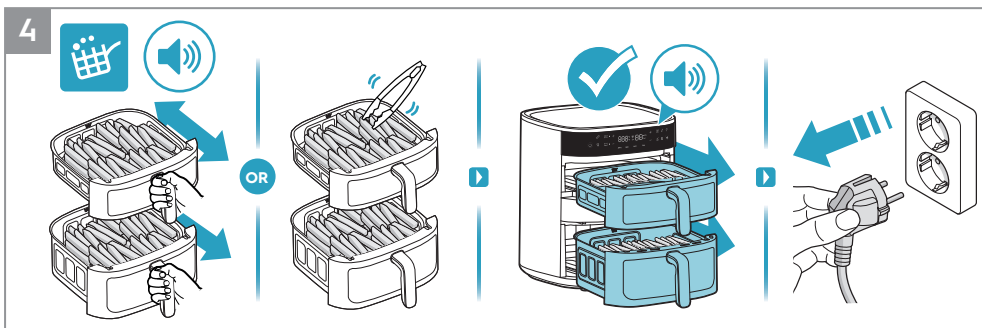

4. When the "Shake Reminder" icon lights up and beeps during the cooking process, use heat-resistant tools to flip the food once or carefully shake the food in the frying basket slightly. At the end of the cooking time, the appliance will issue a beep signal. Unplug the appliance after using it.

GB

BG

DE

ES

FR

GR

IT

PT

NL

CA

SE

FI

DK

NO

HU

AR

How to use - Sync End function

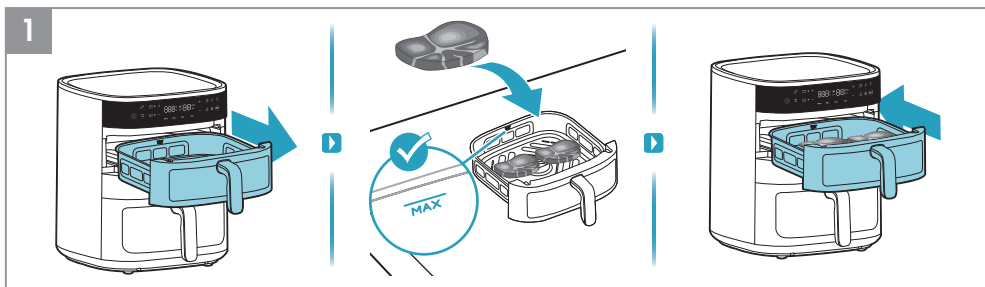

1. Firstly, pull out the top basket and put the food in the basket, for example, steak.

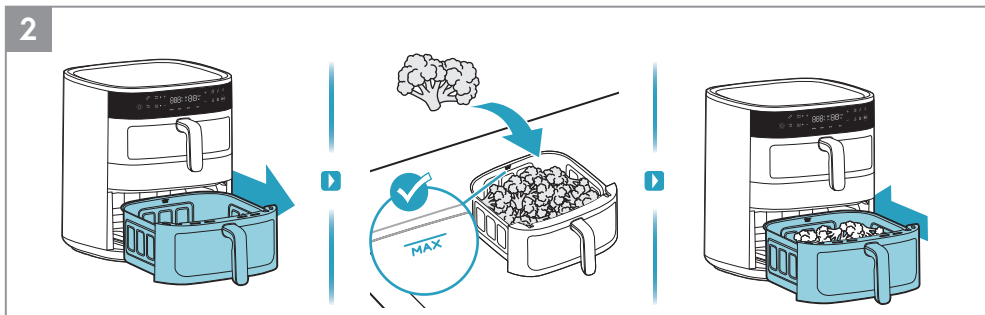

2. Secondly, pull out the bottom basket and put the food in the basket, for example, broccoli.



3. Press the On/Off button. Select the Sync End function. First select the top basket, then select your desired cooking method, for example, Air Fry function. Adjust the time and temperature to your taste or select one of the pre-set recipes, for example, Steak.



4. And then select the bottom basket, select your desired cooking method, for example, Air Fry function. Adjust the time and temperature to your taste or select one of the pre-set recipes. At last, press the Play/Pause button.

GB

BG

DE

ES

FR

GR

IT

PT

NL

CA

SE

FI

DK

NO

HU

AR

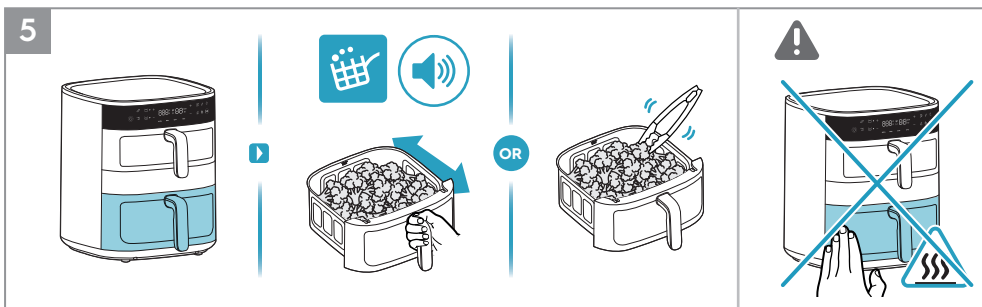

5. Firstly, bottom basket with longer setting time will be prioritized for cooking. When the "Shake Reminder" icon lights up and beeps during the cooking process, use heat-resistant tools to flip the food once or carefully shake the food in the frying basket slightly.

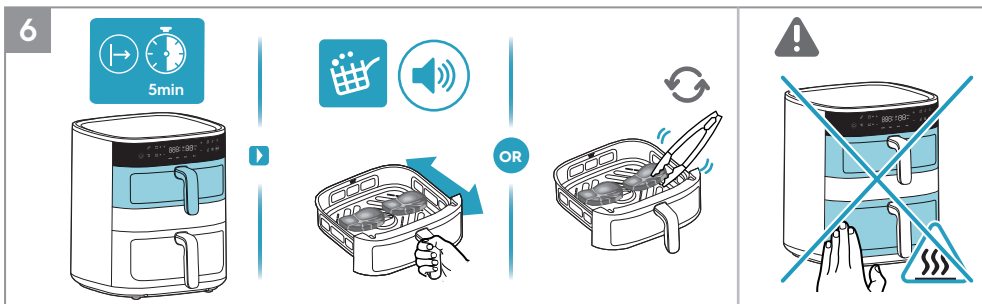

6. Secondly, top basket with shorter setting time will start cooking. When the "Shake Reminder" icon lights up and beeps during the cooking process, use heat-resistant tools to flip the food once or carefully shake the food in the frying basket slightly.

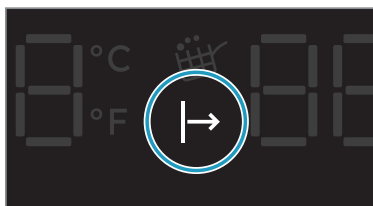

Waiting to cooking indicator

When the "Sync end function" is activated, the basket with shorter cooking time will wait for cooking until the basket with longer cooking time cooking for a while, so that both baskets can end cooking at the same time. During this period, the "waiting to cooking indicator" will light up until cooking begins.

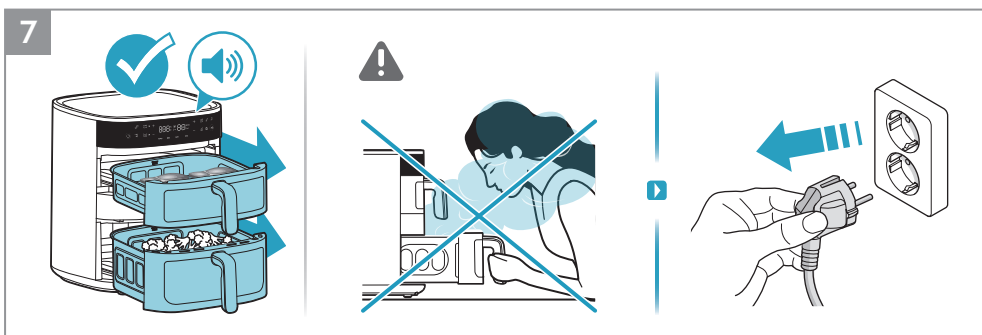

7. At the end of the cooking time, the appliance will issue a beep signal. Unplug the appliance after using it.

GB

BG

DE

ES

FR

GR

IT

PT

NL

CA

SE

FI

DK

NO

HU

AR

Cleaning

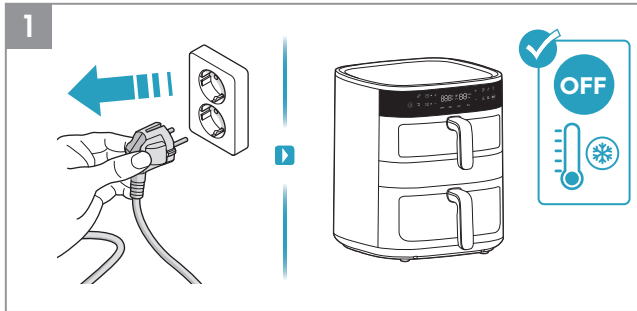

1. Always unplug the appliance and wait until it cools down before cleaning it.
2. Wipe the outside of the appliance with a soft cloth.

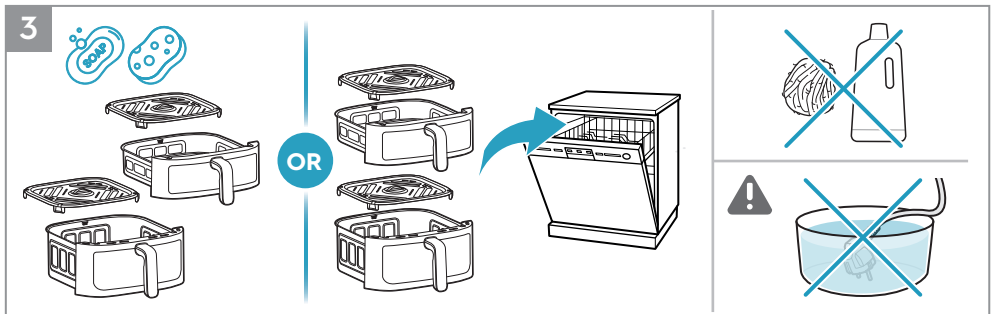

3. Clean the pan and grid with warm water and dish soap, or place them in the dishwasher.

▲ NOTE: Avoid using abrasive cleaning products or metal tools in order to protect the non-stick coating.

CAUTION: Never submerge the product, its cord or plug in water or any other liquid.

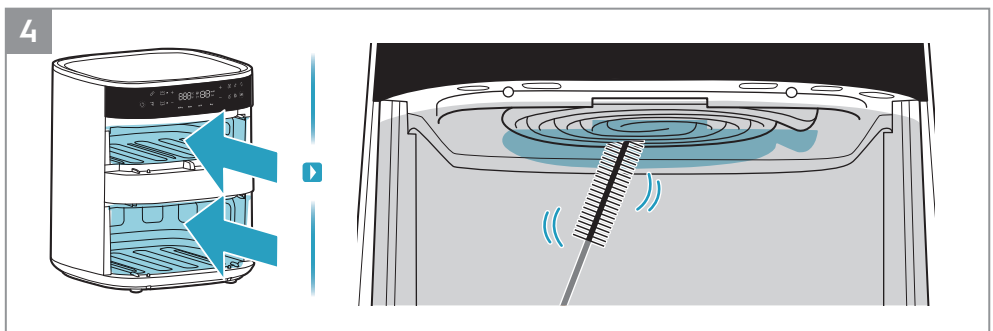

4. Clean the heating element with a cleaning brush.

NOTE: Ensure the appliance is completely cooled down before cleaning the heating element.

GB

BG

DE

ES

FR

GR

IT

PT

NL

CA

SE

FI







































DK

NO

HU

AR

Cooking Guide

							
AirFry	7mm/10mm 	4L 	400g	180°C	18min		
		7L 	400g	180°C	18min		
AirFry		4L 	400g	170°C	8min		
		7L 	400g	170°C	10min		
AirFry		4L 	400g/2pcs	140°C	15min		
		7L 	400g/2pcs	140°C	15min		
AirFry		4L 	1000g/8pcs	180°C	28min		
		7L 	1000g/8pcs	180°C	28min		
AirFry		4L 	400g/2pcs	200°C	10min		
		7L 	400g/2pcs	200°C	10min		
AirFry		4L 	220g/6inches	160°C	12min		
		7L 	220g/6inches	160°C	14min		

GB

BG

DE

ES

FR

GR

IT

PT

NL

CA

SE

























FI

DK

NO

HU

AR

							
AirFry		 7L	1200g	180°C	55min		
Bake		 7L	400g/9pcs	160°C	20min		
Grill		 4L	180g/4pcs	180°C	8min		
		 7L	180g/4pcs	180°C	9min		
Dry		 4L	180g	80°C	3h		
		 7L	180g	80°C	3h		
Dry		 4L	200g	80°C	3h		
		 7L	200g	80°C	3h		

- GB
- BG
- DE
- ES
- FR
- GR
- IT
- PT
- NL
- CA
- SE
- FI
- DK
- NO
- HU
- AR

What to do if...

Problem	Check if...
You cannot activate or operate the appliance.	<ul style="list-style-type: none"> • The appliance is correctly connected to an electrical supply. • The baskets are in the correct position. Ensure they are completely pushed into the appliance to enable the electrical supply. • The cooking time is set.
You cannot slide the basket into the appliance.	<ul style="list-style-type: none"> • The basket is filled over its maximum capacity. • The basket is placed correctly. It has to click when you place it in the unit. • There's an object under the basket that is an obstacle to close it properly.
White smoke comes out of the appliance.	<ul style="list-style-type: none"> • The food you prepare is too greasy. • The basket, grid and heating element are clean.
The display shows E1	<ul style="list-style-type: none"> • Top bucket open circuit
The display shows E2	<ul style="list-style-type: none"> • Top bucket short circuit
The display shows E3	<ul style="list-style-type: none"> • Bottom bucket open circuit
The display shows E4	<ul style="list-style-type: none"> • Bottom bucket short circuit
The display shows E5	<ul style="list-style-type: none"> • Control PCBA communication failure.
The display shows E6	<ul style="list-style-type: none"> • Power PCBA communication failure.

* In case the display shows error codes, the appliance must be repaired by a Service Center.

Technical Data

Product	Air Fryer
Model	AAFD11B
Voltage (V~)	220 V ~ 240 V
Power (W)	2700 W
Frequency (Hz)	50 ~ 60 Hz
Capacity	4 L + 7 L

GB

BG

DE

ES

FR

GR

IT

PT

NL

CA

SE

FI

DK

NO

HU

AR



Книжка с указания

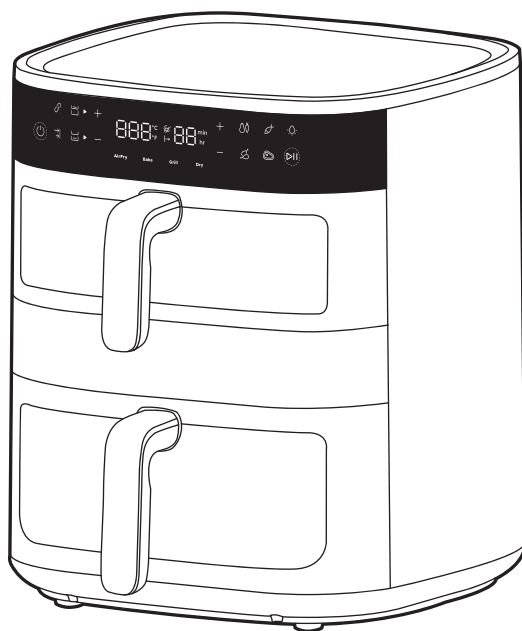

Двоен Еър фраер 800 (800 Air Fryer Dual)

Общ преглед

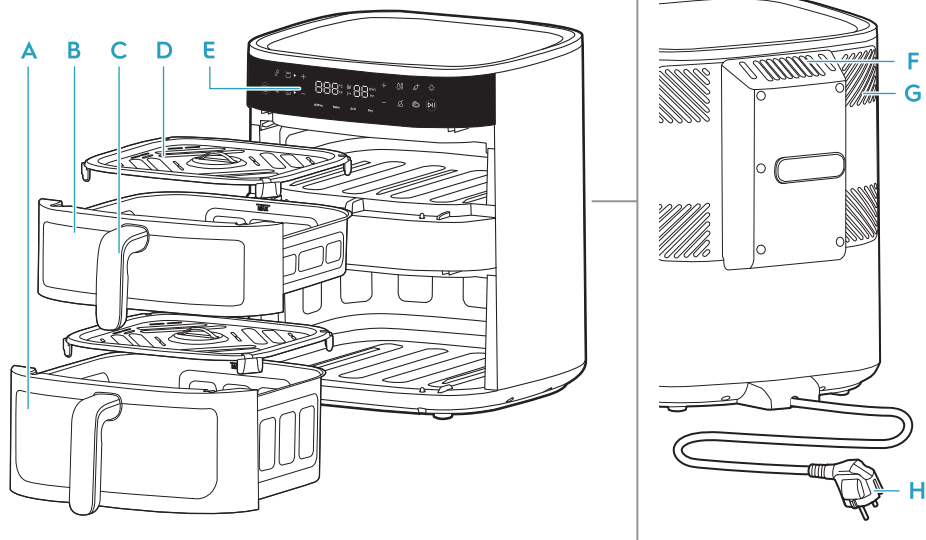

- A** Долна кошница (7л) **C** Дръжка на кошницата **E** Контролен панел **G** Система за охлаждане
B Горна кошница (4л) **D** Решетка **F** Изход за въздух **H** Основен кабел

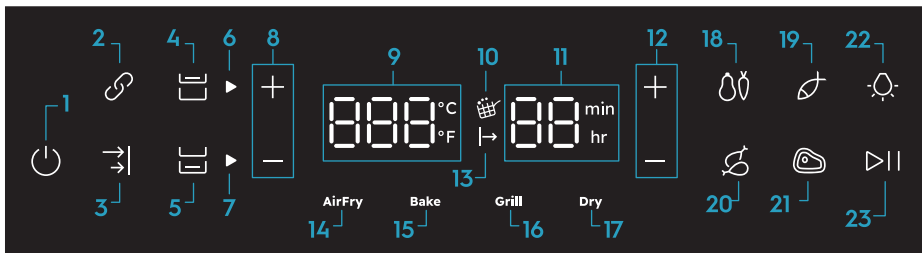

- | | | | |
|-------------------------------------|--|--|-----------------------------|
| 1. Вкл./Изкл. | 6. Индикатор на горната кошница | 10. Напомняне за разклащане | 16. Функция за грил |
| 2. Функция "Връзка" | 7. Индикатор на долната кошница | 11. Индикатор за време (AirFry: 1-99 мин, Дехидратиране: 1-5 ч.) | 17. Функция за сушене |
| 3. Функция "Синхронизиране на края" | 8. Контрол на температурата | 12. Контрол на времето | 18. Зеленчуци |
| 4. Контрол на горната кошница | 9. Индикатор за температурата (40-200°C) | 13. Изчакване на готвенето | 19. Риба |
| 5. Контрол на долната кошница | | 14. Функция "AirFry" | 20. Пиле |
| | | 15. Функция за печене | 21. Пържола |
| | | | 22. Контрол на осветлението |
| | | | 23. Пускане/Пауза |

GB

BG

DE

ES

FR

GR

IT

PT

NL

CA

SE

FI

DK

NO

HU

AR

Преди да използвате за първи път

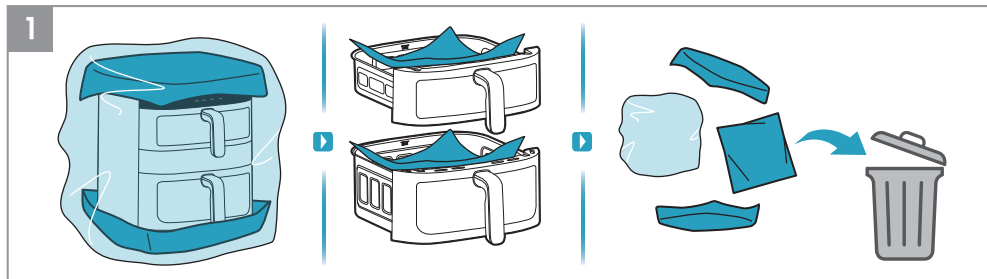

1. Премахнете всички опаковки и защитния материал.

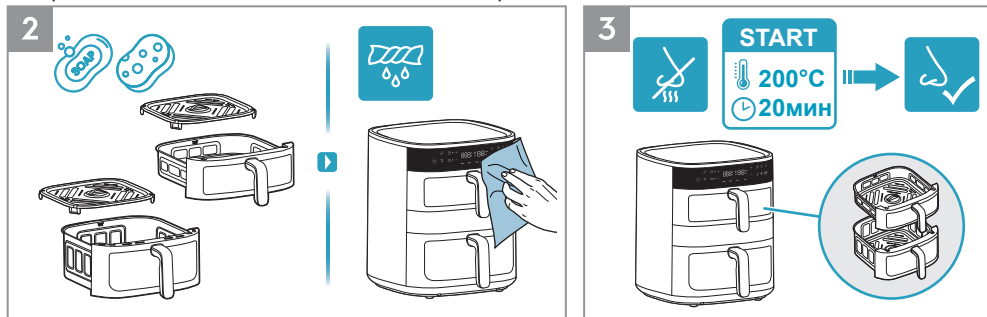



2. Почистете тавичката и решетката с топла вода и препарат за миене на съдове. Избършете вътрешността и външността на уреда с мека кърпа.

3. Нормално е нов уред да излъчва миризми при първите няколко използвания. За да избегнете това, пуснете празния еър фраер на 200 °C за 20 минути преди да го използвате за първи път.

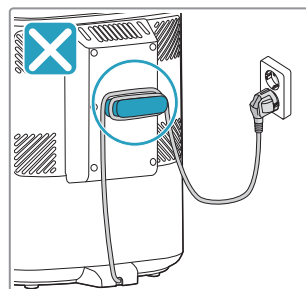
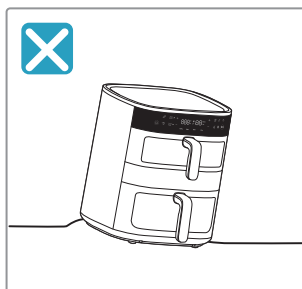
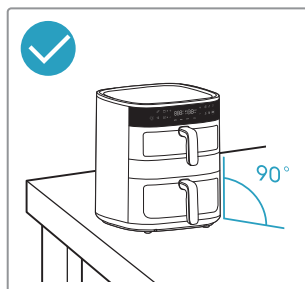
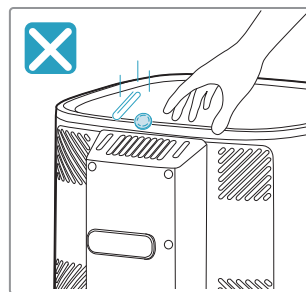
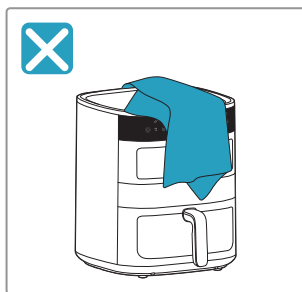
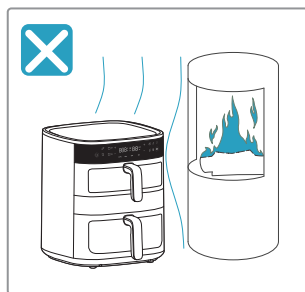



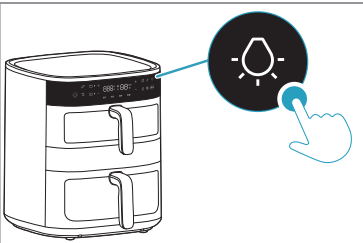
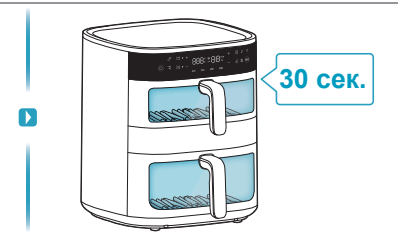

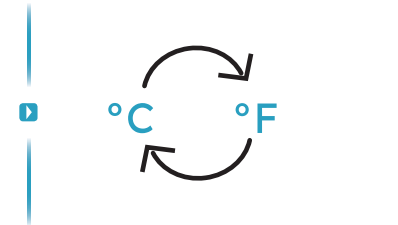







! Мерки за безопасност



Контрол на осветлението и преобразуване на температурната скала

 <p>Контрол на осветлението</p>		 <p>30 сек.</p>
<p>°C/°F</p> <p>Преобразуване на температурната скала</p>	 <p>30 сек.</p>	

Избор на кошница

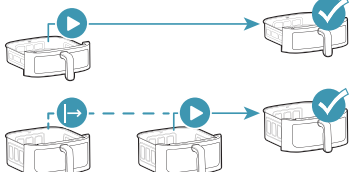
	 <p>4л</p>	 <p>7л</p>	
 <p>Горна кошница</p>			
 <p>Долна кошница</p>			
 <p>Функция "Връзка"</p>			
 <p>Функция "Синхронизиране на края"</p>			

GB

BG

DE

ES

FR

GR

IT

PT

NL

CA

SE

FI















DK

NO

HU

AR

Предварително зададени функции

					
Air Fry	180°C	15мин	60~200°C	1~99мин	
	170°C	10мин	60~200°C	1~99мин	
	140°C	15мин	60~200°C	1~99мин	
	180°C	30мин	60~200°C	1~99мин	
	200°C	10мин	60~200°C	1~99мин	
Bake	170°C	15мин	60~200°C	1~99мин	
Grill	200°C	5мин	60~200°C	1~99мин	
Dry	80°C	5ч	40~80°C	1~5ч	

Преди готвенето

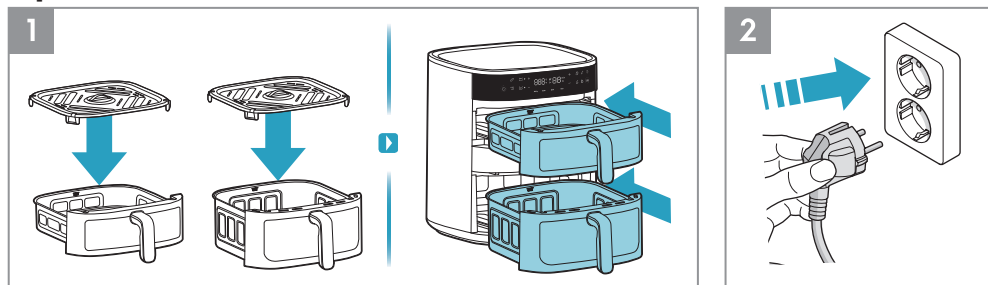

1. Преди всяко готвене поставете решетката в кошницата (не е необходимо да се отстранява термоустойчивата силиконова подложка на решетката) и изцяло вкарайте кошницата в уреда.
2. Включете щепсела в електрическата мрежа.

Как да използвате - Само едната кошница

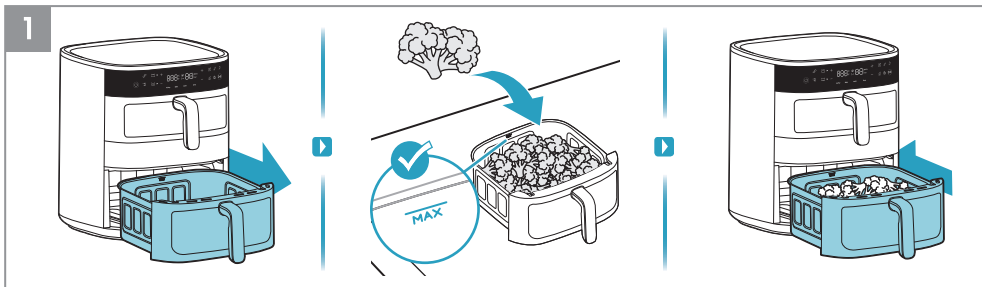

1. Извадете една кошница и я поставете върху стабилна повърхност, сложете храната в кошницата, като спазвате указанията за максималния капацитет. След това вкарайте кошницата с храната изцяло в уреда.

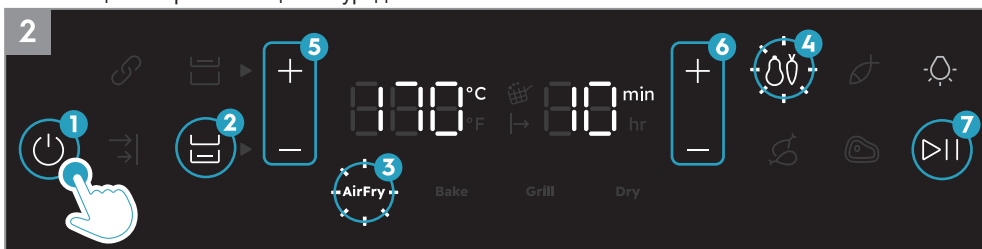

2. Натиснете бутона Вкл./Изкл. Първо изберете кошницата с храната. След това изберете желаните метод на готвене, например функцията „Air Fry“. Настройте времето и температурата според своя вкус или изберете една от предварително зададените рецепти, например Зеленчуци. Накрая натиснете бутона Пускане/Пауза.

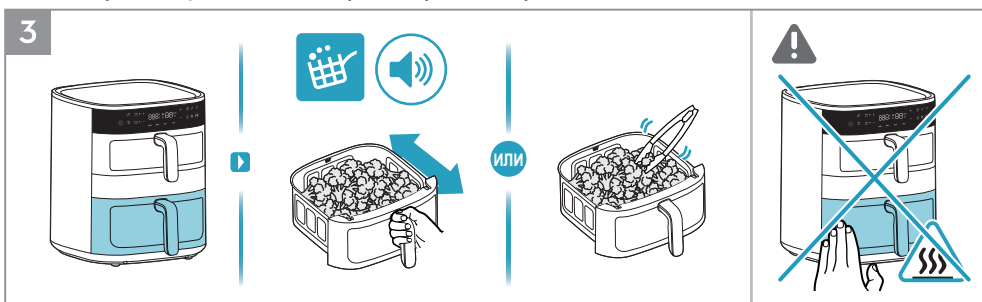

3. Когато иконата Напомняне за разклащане светне и се чуе звуков сигнал по време на готвенето, използвайте термоустойчиви прибори, за да обърнете храната веднъж или внимателно разклатете леко храната в кошницата за пържене.

⚠ **ВНИМАНИЕ:** Не разклащайте кошницата за пържене енергично, за да избегнете пръски от храна и изгаряния.

⚠ **ВНИМАНИЕ:** Внимавайте с горещите повърхности когато използвате уреда.

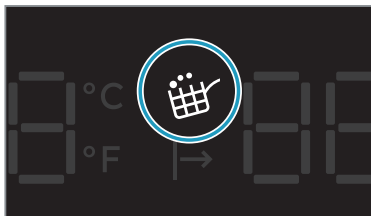

Напомняне за разклащане

“Напомнянето за разклащане” се активира по време на функцията “Air Fry” и предварително зададените рецепти, като зеленчуци, риба, пилешки бутчета и пържола. Когато е време да разклатите или обърнете храната, иконата “Напомняне за разклащане” ще светне и ще мига в продължение на една минута, а звуковият сигнал ще се повтори три пъти.

“Напомнянето за разклащане” не е задължително, затова готвенето ще продължи както обикновено, дори ако храната не бъде обърната или разклатена.

GB

BG

DE

ES

FR

GR

IT

PT

NL

CA

SE

FI

DK

NO

HU

AR

4

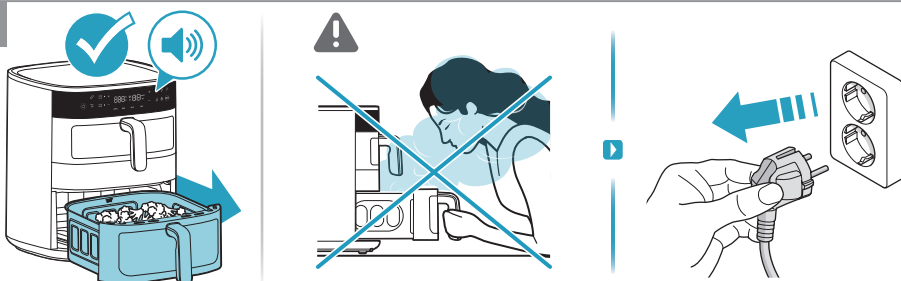

4. В края на времето за готвене уредът ще издаде звуков сигнал. Внимателно извадете кошницата и я поставете върху топлоустойчива повърхност. След употреба изключете уреда от контакта.

⚠ **ВНИМАНИЕ:** Когато отворите кошницата по време на готвенето или в края му, от нея може да излезе гореща пара. Уверете се, че лицето и ръцете ви са далеч от парата, когато я отваряте.

Как да използвате - горна + долна кошница

1

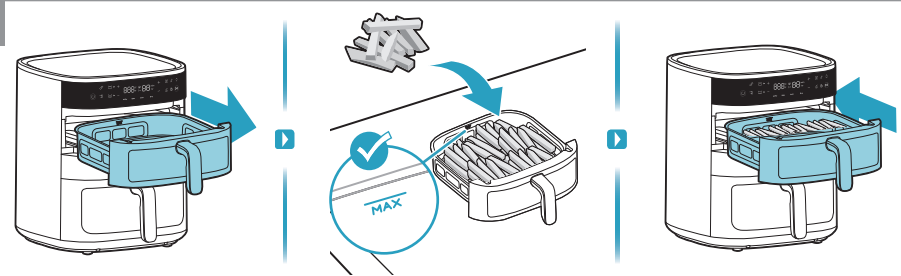

1. Първо извадете горната кошница и сложете храната в нея, например пържени картофи.

2

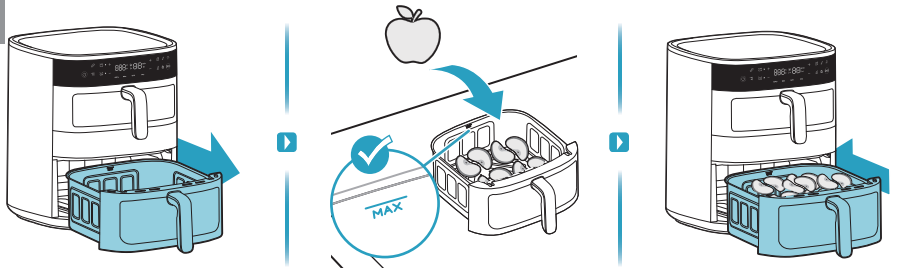

2. Второ, извадете долната кошница и сложете в нея храната, например резени ябълка.

3



3. Натиснете бутона Вкл./Изкл. Първо изберете горната кошница. След това изберете желания метод на готвене, например функцията "Air Fry". Настройте времето и температурата според своя вкус или изберете една от предварително зададените рецепти, например Зеленчуци. Накрая натиснете бутона Пускане/Пауза.

GB

BG

DE

ES

FR

GR

IT

PT

NL

CA

SE

FI

DK

NO

HU

AR



4. Второ, изберете долната кошница. След това изберете желания метод на готвене, например функция "Сушене". Настройте времето и температурата според своите предпочитания. Накрая натиснете бутона Пускане/Пауза.

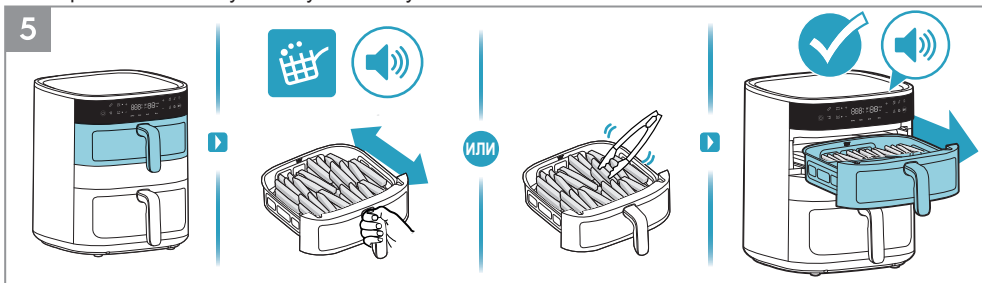

5. Когато иконата Напомняне за разклащане светне и се чуе звуков сигнал по време на готвенето, използвайте термоустойчиви прибори, за да обърнете храната веднъж или внимателно разклатете леко храната в кошницата за пържене. В края на времето за готвене на горната кошница уредът ще издаде звуков сигнал.

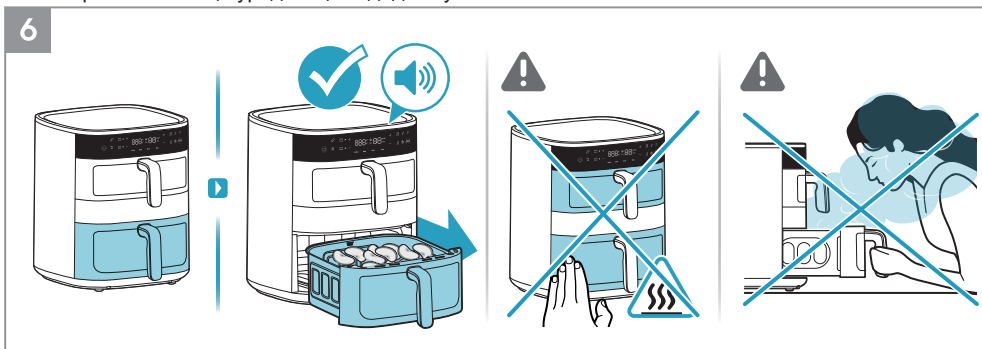

6. В края на времето за готвене на долната кошница уредът ще издаде звуков сигнал.

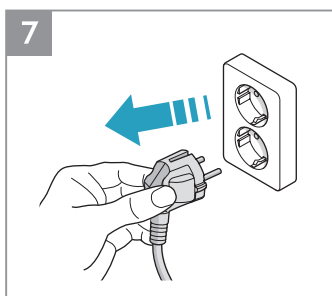

7. След употреба изключете уреда от контакта.

GB

BG

DE

ES

FR

GR

IT

PT

NL

CA

SE

FI

DK

NO

HU

AR

Как да използвате - Функция “Връзка”

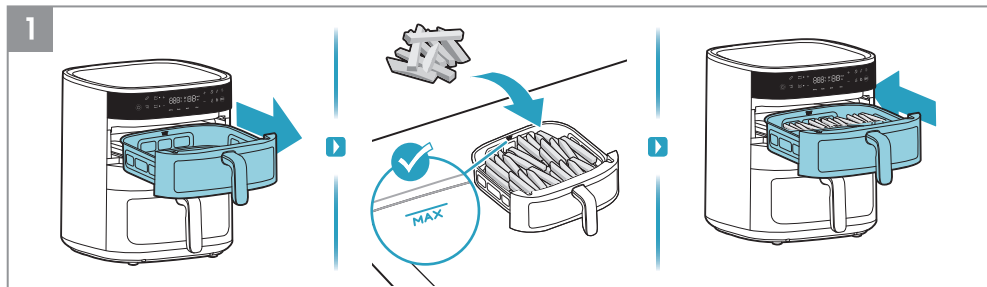

1. Първо извадете горната кошница и сложете храната в нея, например пържени картофи.

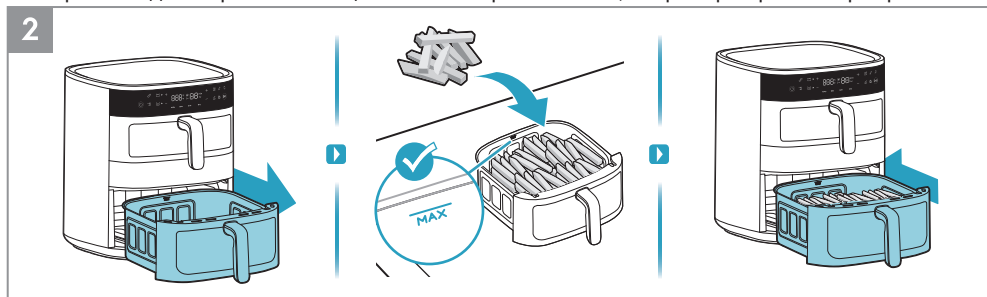

2. Второ, извадете долната кошница и сложете в нея храната, например пържени картофи.



3. Натиснете бутона Вкл./Изкл. Първо изберете функцията “Връзка”. След това изберете желаня метод на готвене, например функцията “Air Fry”. Настройте времето и температурата според своя вкус или изберете една от предварително зададените рецепти. Накрая натиснете бутона Пускане/Пауза.

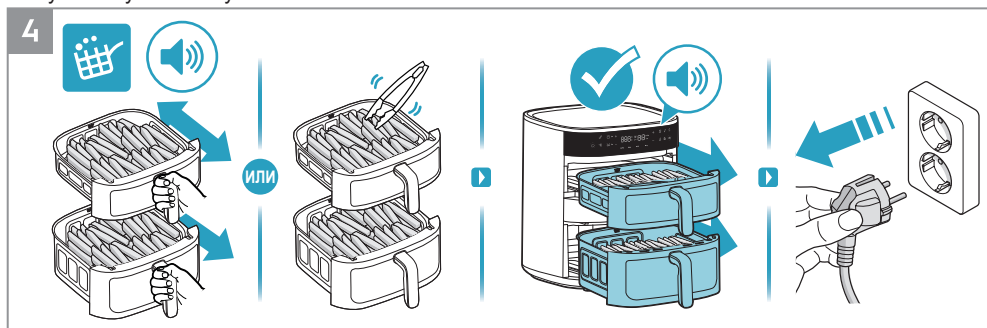

4. Когато иконата Напомняне за разклащане светне и се чуе звуков сигнал по време на готвенето, използвайте термоустойчиви прибори, за да обърнете храната веднъж или внимателно разклатете леко храната в кошницата за пържене. В края на времето за готвене уредът ще издаде звуков сигнал. След употреба изключете уреда от контакта.

Как да използвате - Функция “Синхронизиране на края”

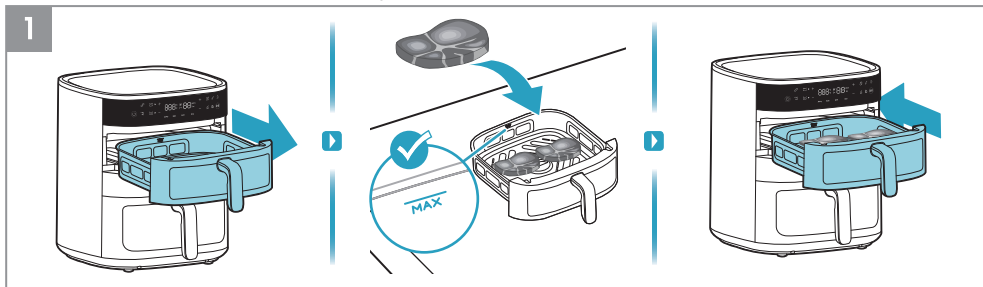

1. Първо извадете горната кошница и сложете храната в нея, например пържола.

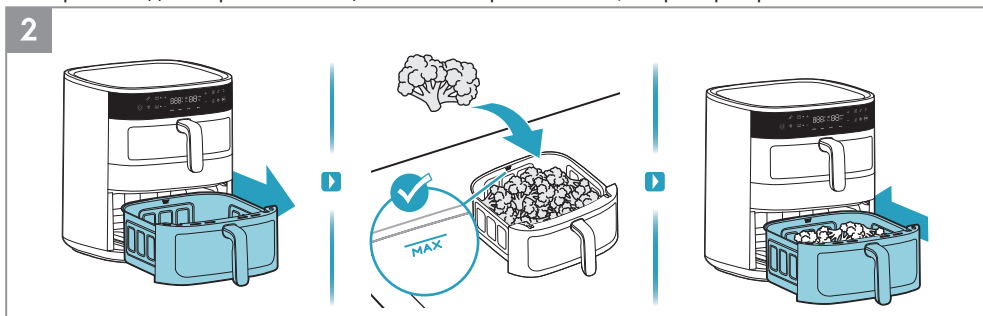

2. Второ, извадете долната кошница и сложете храната в нея, например броколи.



3. Натиснете бутона Вкл./Изкл. Изберете функция “Синхронизиране на края”. Първо изберете горната кошница, след това изберете желания начин на готвене, например функцията “Air Fry”. Настройте времето и температурата според своя вкус или изберете една от предварително зададените рецепти, например за пържола.



4. След това изберете долната кошница и желания начин на готвене, например функцията “Air Fry”. Настройте времето и температурата според своя вкус или изберете една от предварително зададените рецепти. Накрая натиснете бутона Пускане/Пауза.

GB

BG

DE

ES

FR

GR

IT

PT

NL

CA

SE

FI

DK

NO

HU

AR

5

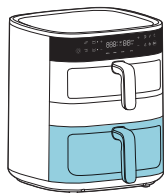

ИЛИ



5. Първо, долната кошница с по-дълго настроено време за готвене ще бъде с приоритет. Когато иконата Напомняне за разклащане светне и се чуе звуков сигнал по време на готвенето, използвайте термоустойчиви прибори, за да обърнете храната веднъж или внимателно разклатете леко храната в кошницата за пържене.

6

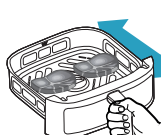
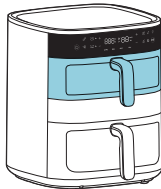

ИЛИ



6. Второ, горната кошница с по-кратко настроено време за готвене ще започне да се готви. Когато иконата Напомняне за разклащане светне и се чуе звуков сигнал по време на готвенето, използвайте термоустойчиви прибори, за да обърнете храната веднъж или внимателно разклатете леко храната в кошницата за пържене.

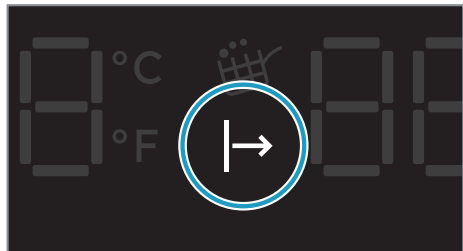

Индикатор за изчакване на готвенето

Когато функцията "Синхронизиране на края" е активирана, кошницата с по-кратко време за готвене ще изчака, докато кошницата с по-дълго време за готвене се готви за известно време, така че и двете кошници да могат да приключат готвенето едновременно. През това време индикаторът "изчакване на готвенето" ще свети, докато готвенето не започне.

7

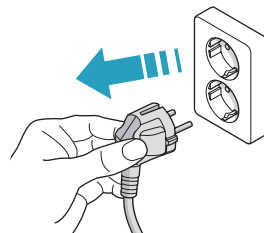
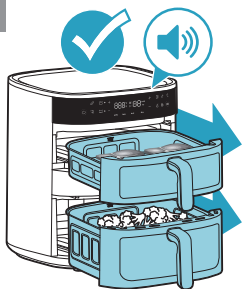

7. В края на времето за готвене уредът ще издаде звуков сигнал. След употреба изключете уреда от контакта.

GB

BG

DE

ES

FR

GR

IT

PT

NL

CA

SE

FI

DK

NO

HU

AR

Почистване

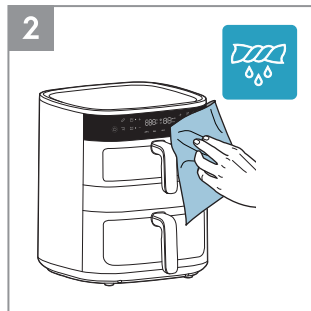
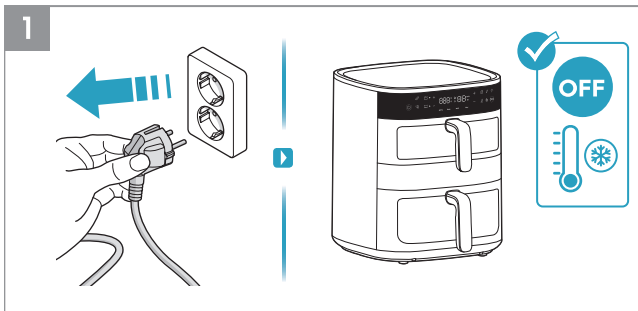

1. Винаги изключвайте уреда от електрическата мрежа и изчакайте да изстине, преди да го почистите.
2. Избършете външната част на уреда с мека кърпа.

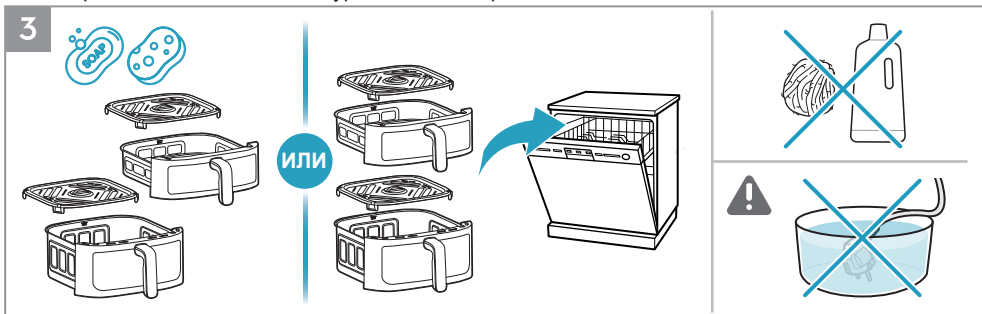

3. Почистете тавичката и решетката с топла вода и препарат за миене на съдове или ги сложете в съдомиялната.

ΔБЕЛЕЖКА: Избягвайте да използвате абразивни почистващи продукти или метални инструменти, за да предпазите незалепващото покритие.

ВНИМАНИЕ: Никога не потапяйте продукта, кабела или щепсела му във вода или друга течност.

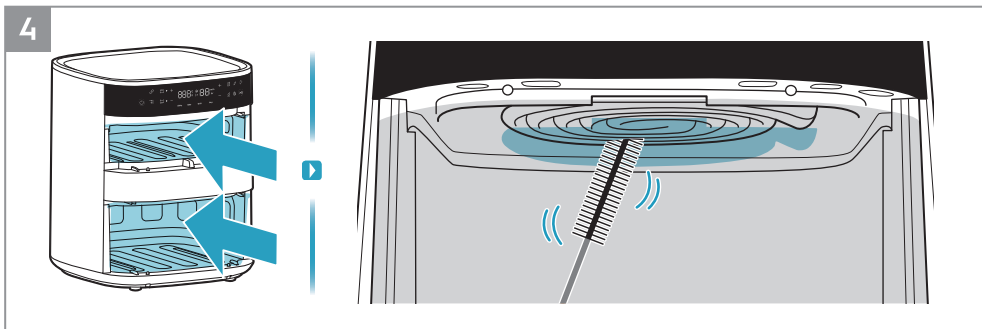

4. Почистете нагревателния елемент с четка за почистване.

БЕЛЕЖКА: Уверете се, че уредът е напълно изстинал, преди да почистите нагревателния елемент.

GB

BG

DE

ES

FR

GR

IT

PT

NL

CA

SE

FI































DK

NO

HU

AR

Ръководство за готвене

Recipe							
AirFry	7mm/10mm 	 4л	400г	180°C	18мин		
	 7л	400г	180°C	18мин			
AirFry		 4л	400г	170°C	8мин		
		 7л	400г	170°C	10мин		
AirFry		 4л	400г/2 бр.	140°C	15мин		
		 7л	400г/2 бр.	140°C	15мин		
AirFry		 4л	1000г/8 бр.	180°C	28мин		
		 7л	1000г/8 бр.	180°C	28мин		
AirFry		 4л	400г/2 бр.	200°C	10мин		
		 7л	400г/2 бр.	200°C	10мин		
AirFry		 4л	220г/6 инча	160°C	12мин		
		 7л	220г/6 инча	160°C	14мин		

GB

BG

DE

ES

FR

GR

IT

PT

NL

CA

SE













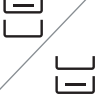













FI

DK

NO

HU

AR

							
AirFry		 7л	1200г	180°C	55мин		
AirFry		 7л	400г/96р.	160°C	20мин		
Grill		 4л	180г/46р.	180°C	8мин		
Grill		 7л	180г/46р.	180°C	9мин		
Dry		 4л	180г	80°C	3 ч.		
Dry		 7л	180г	80°C	3 ч.		
Dry		 4л	200г	80°C	3 ч.		
Dry		 7л	200г	80°C	3 ч.		

GB

BG

DE

ES

FR

GR

IT

PT

NL

CA

SE

FI

DK

NO

HU

AR

Какво да направите, ако...

Проблем	Проверете дали...
Не можете да активирате или да работите с уреда.	<ul style="list-style-type: none">• Уредът е правилно свързан към електрическата мрежа.• Кошниците са в правилната позиция. Уверете се, че са напълно вкарани в уреда, за да се включи електрозахранването.• Времето за готвене е настроено.
Не можете да вкарете кошницата в уреда.	<ul style="list-style-type: none">• Кошницата е напълнена над максималния си капацитет.• Кошницата е поставена правилно. Тя трябва да щракне, когато я поставите в устройството.• Под кошницата има предмет, който пречи да се затвори правилно.
От уреда излиза бял дим.	<ul style="list-style-type: none">• Пригответяната храна е прекалено мазна.• Кошницата, решетката и нагревателният елемент са чисти.
На дисплея се показва E1.	<ul style="list-style-type: none">• Отворена верига на горната тавичка.
На дисплея се показва E2.	<ul style="list-style-type: none">• Къса верига на горната тавичка.
На дисплея се показва E3.	<ul style="list-style-type: none">• Отворена верига на долната тавичка.
На дисплея се показва E4.	<ul style="list-style-type: none">• Къса верига на долната тавичка.
На дисплея се показва E5.	<ul style="list-style-type: none">• Неизправност в комуникацията на контролния РСВА.
На дисплея се показва E6.	<ul style="list-style-type: none">• Неизправност в комуникацията на захранващия РСВА.

* В случай че на дисплея се покажат кодове за грешка, уредът трябва да бъде ремонтиран от сервизен център.

Технически данни

Продукт	Еър Фраер
Модел	AAFD11B
Волтаж (V~)	220 V ~ 240 V
Захранване (W)	2700 W
Честота (Hz)	50 ~ 60 Hz
Капацитет	4 л + 7 л

GB

BG

DE

ES

FR

GR

IT

PT

NL

CA

SE

FI

DK

NO

HU

AR



Benutzerhandbuch

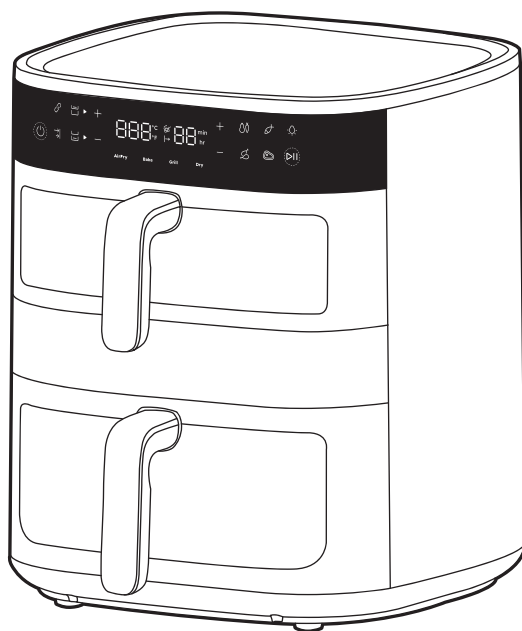

800 Heißluftfritteuse Dual

Allgemeine Übersicht

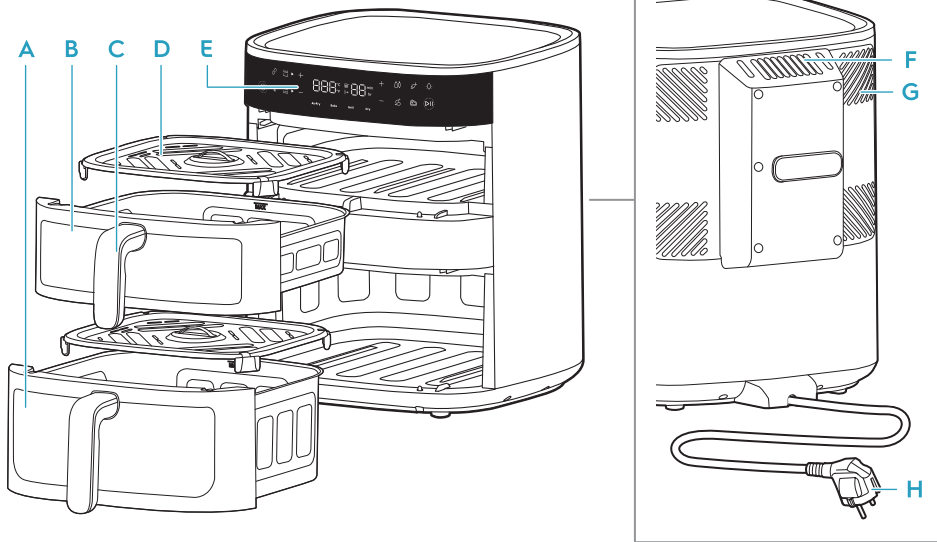

- | | | | |
|----------------------------|----------------------|----------------------|---------------------|
| A Unterer Korb (7L) | C Korbgriff | E Bedienfeld | G Kühlsystem |
| B Oberer Korb (4L) | D Rosteinsatz | F Luftauslass | H Hauptkabel |

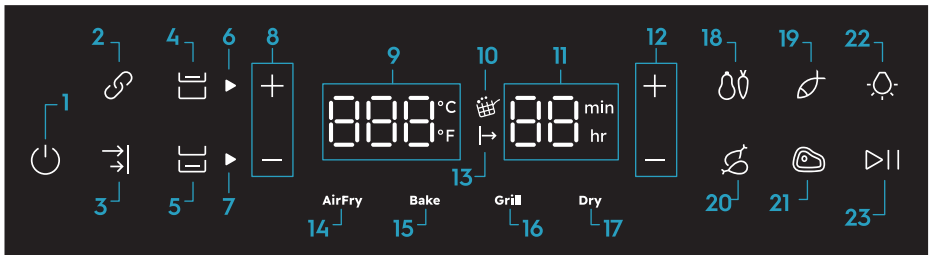

- | | | | |
|-----------------------------|---|---------------------------------|-----------------------------|
| 1. Ein/Aus | 9. Temperaturanzeige (40-200 °C) | 13. Warten auf das Garen | 19. Fisch |
| 2. Verbindungsfunktion | 10. Schüttel-/Wendeerinnerung | 14. Funktion Heißluftfrittieren | 20. Huhn |
| 3. Sync-End-Funktion | 11. Zeitanzeige (Heißluftfrittieren: 1-99 min, Dörren: 1-5 h) | 15. Backfunktion | 21. Steak |
| 4. Einstellung oberer Korb | 12. Zeiteinstellung | 16. Grillfunktion | 22. Beleuchtungseinstellung |
| 5. Einstellung unterer Korb | | 17. Dörrfunktion | 23. Start/Pause |
| 6. Anzeige oberer Korb | | 18. Gemüse | |
| 7. Anzeige unterer Korb | | | |
| 8. Temperaturregelung | | | |

Erste Inbetriebnahme

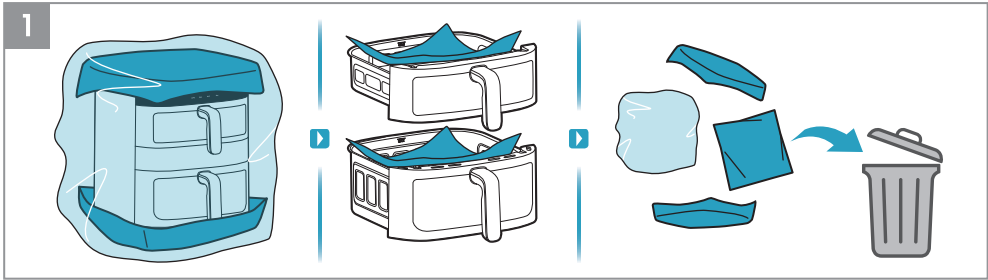

1. Entfernen Sie die Verpackung und die Schutzhülle.

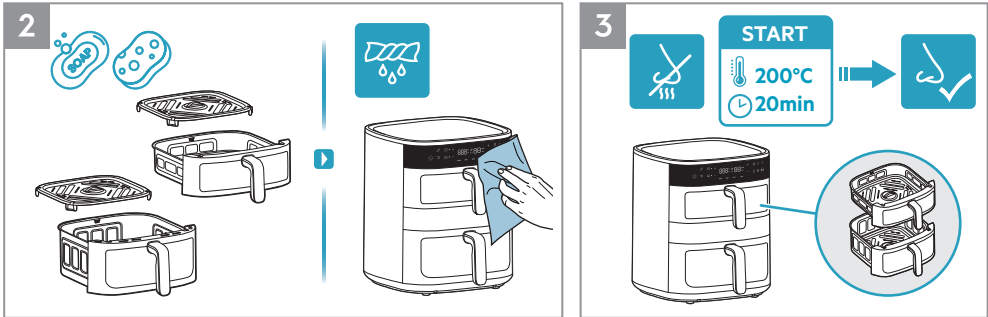

2. Reinigen Sie die Pfanne und den Rösteinsatz mit warmem Wasser und Geschirreiniger. Wischen Sie die Innen- und Außenseite des Geräts mit einem weichen Tuch ab.

3. Es ist normal, dass ein neues Gerät beim ersten Betrieb riecht. Lassen Sie die leere Heißluftfritteuse vor dem ersten Betrieb bei 200 °C für 20 Minuten laufen, um das zu vermeiden.

! Sicherheitsvorkehrungen

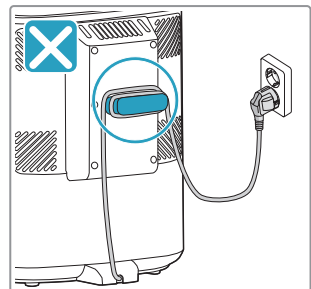
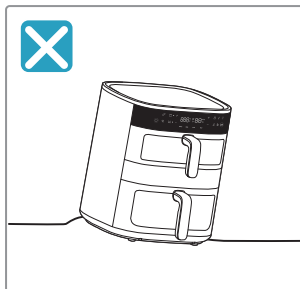
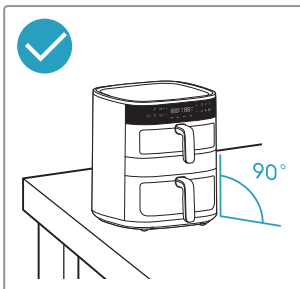
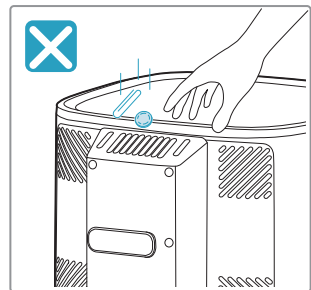
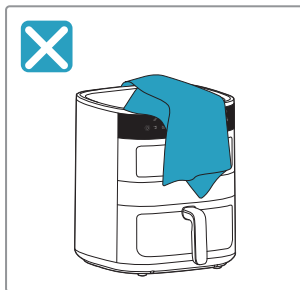
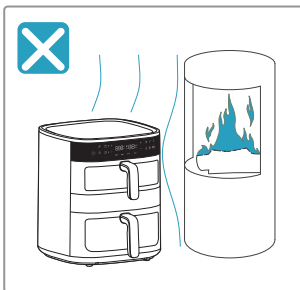

GB

BG

DE

ES

FR

GR

IT

PT

NL

CA

SE

FI



DK

NO





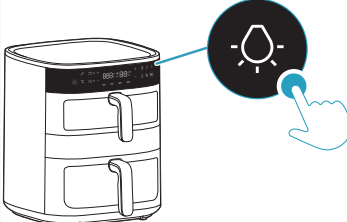
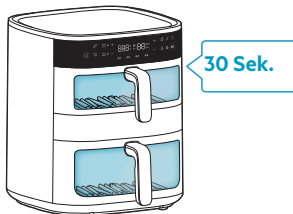
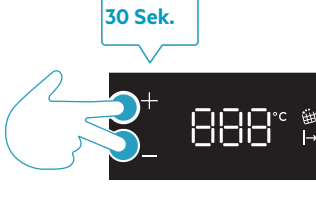



HU

AR

Beleuchtungseinstellung & Umrechnung der Temperatureinheit

 <p>Beleuchtungseinstellung</p>		
<p>°C/°F</p> <p>Umrechnung der Temperatureinheit</p>		

Korbauswahl

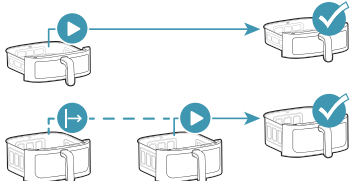
	 <p>4L</p>	 <p>7L</p>	
 <p>Oberer Korb</p>	<input checked="" type="checkbox"/>		
 <p>Unterer Korb</p>		<input checked="" type="checkbox"/>	
 <p>Verbindungsfunktion</p>	<input checked="" type="checkbox"/>	<input checked="" type="checkbox"/>	
 <p>Sync-End-Funktion</p>	<input checked="" type="checkbox"/>	<input checked="" type="checkbox"/>	

GB

BG

DE

ES

FR

GR

IT

PT

NL

CA

SE

FI















DK

NO

HU

AR

Voreingestellte Funktionen

 AirFry					
AirFry	180°C	15min	60~200°C	1-99min	
	170°C	10min	60~200°C	1-99min	
	140°C	15min	60~200°C	1-99min	
	180°C	30min	60~200°C	1-99min	
	200°C	10min	60~200°C	1-99min	
Bake	170°C	15min	60~200°C	1-99min	
Grill	200°C	5min	60~200°C	1-99min	
Dry	80°C	5h	40~80°C	1-5h	

GB

BG

DE

ES

FR

GR

IT

PT

NL

CA

SE

FI

DK

NO

HU

AR

Vor dem Garen

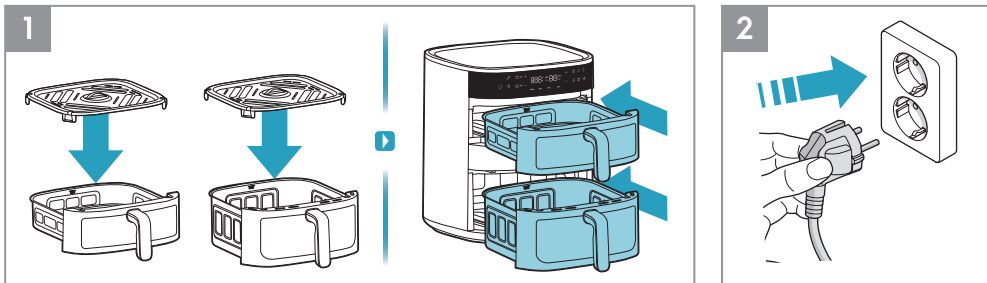

1. Setzen Sie vor jedem Garen den Rösteinsatz in den Korb ein (das hitzebeständige Silikon-Pad des Rösteinsatzes muss nicht entfernt werden) und schieben Sie den Korb vollständig in das Gerät ein.
2. Stecken Sie den Netzstecker in die Steckdose.

Verwendung – Einzelkorb

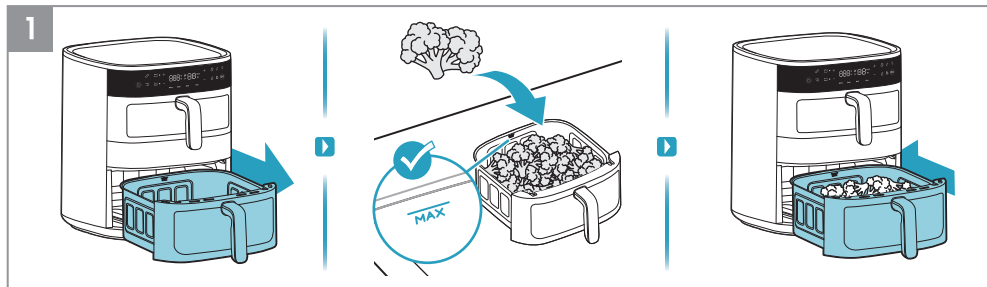

1. Ziehen Sie einen Korb heraus und stellen Sie ihn auf eine stabile Oberfläche. Geben Sie das Gargut in den Korb und beachten Sie dabei die Kapazitätsanzeige "MAX.". Schieben Sie den Korb dann vollständig in das Gerät ein.



2. Drücken Sie die Ein-/Aus-Taste. Zuerst wählen Sie den Korb mit dem Gargut aus. Dann wählen Sie Ihre gewünschte Garmethode aus, zum Beispiel die Funktion Heißluftfrittieren. Stellen Sie die Zeit und die Temperatur nach Bedarf ein oder wählen Sie eines der voreingestellten Rezepte aus, zum Beispiel "Gemüse". Zum Schluss drücken Sie die Start-/Pause-Taste.

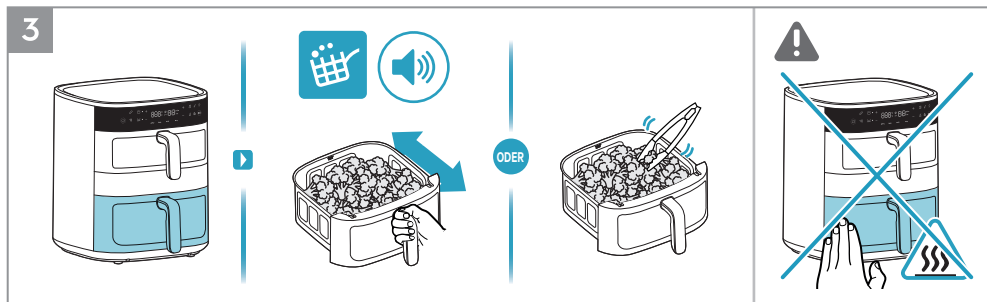

3. Wenn während des Garvorgangs das Symbol "Schüttel-/Wendeerinnerung" aufleuchtet und ein Signalton ertönt, wenden Sie die Speisen mit hitzebeständigen Utensilien einmal oder schütteln Sie den Frittierkorb vorsichtig.

⚠ **VORSICHT:** Schütteln Sie den Frittierkorb nicht zu sehr, um Spritzer und Verbrennungen zu vermeiden.

⚠ **VORSICHT:** Vorsicht vor heißen Oberflächen, wenn das Gerät in Betrieb ist.

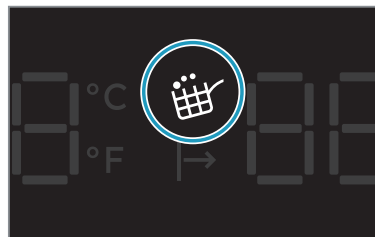

Schüttel-/Wendeerinnerung

Die "Schüttel-/Wendeerinnerung" ist während der Funktion Heißluftfrittieren und den voreingestellten Rezepten wie Gemüse, Fisch, Hähnchen und Steak aktiviert.

Wenn es Zeit ist, Ihre Speisen zu schütteln oder zu wenden, leuchtet das Symbol "Schüttel-/Wendeerinnerung" auf und blinkt eine Minute lang, während dreimal ein Piepton ertönt.

Die "Schüttel-/Wendeerinnerung" ist nicht unbedingt erforderlich, daher wird der Garvorgang wie gewohnt fortgesetzt, auch wenn das Gargut nicht gewendet oder geschüttelt wird.



4. Am Ende der Garzeit gibt das Gerät einen Signalton ab. Entnehmen Sie den Korb vorsichtig und stellen Sie ihn auf eine hitzebeständige Oberfläche. Nehmen Sie das Gerät nach der Verwendung vom Strom.

⚠ **VORSICHT:** Beim Öffnen des Korbs während oder nach dem Garvorgang kann heißer Dampf austreten. Achten Sie darauf, dass Ihr Gesicht, Ihre Arme und Hände beim Öffnen nicht in die Nähe des Dampfes kommen.

Verwendung – Oberer + unterer Korb

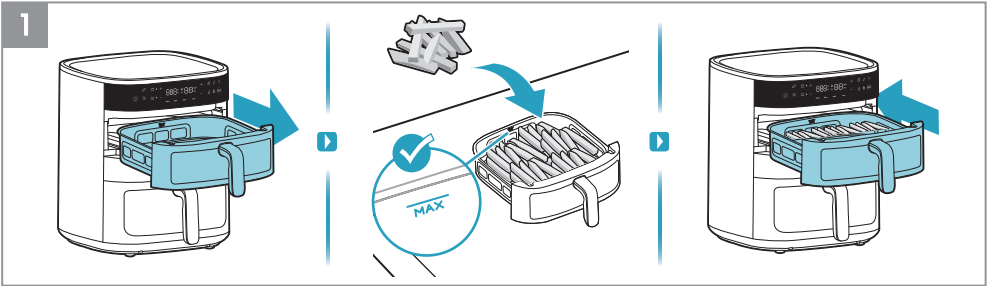

1. Zuerst ziehen Sie den oberen Korb heraus und legen das Gargut in den Korb, zum Beispiel Pommes frites.

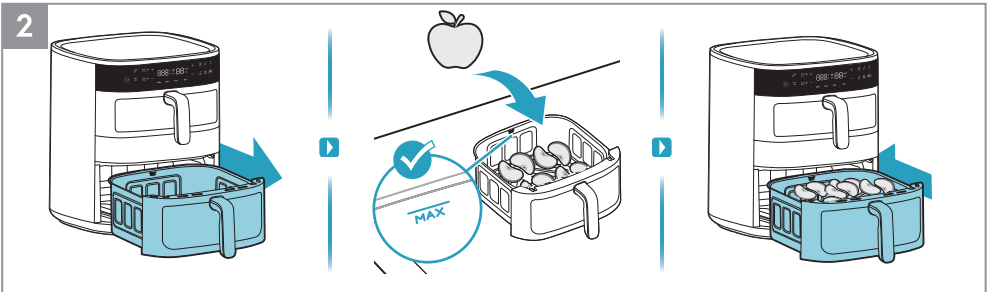

2. Ziehen Sie als Zweites den unteren Korb heraus und legen Sie weiteres Gargut hinein, zum Beispiel Apfelscheiben.



3. Drücken Sie die Ein-/Aus-Taste. Wählen Sie zuerst den oberen Korb aus. Dann wählen Sie Ihre gewünschte Garmethode aus, zum Beispiel die Funktion Heißluftfrittieren. Stellen Sie die Zeit und die Temperatur nach Bedarf ein oder wählen Sie eines der voreingestellten Rezepte aus, zum Beispiel "Gemüse". Zum Schluss drücken Sie die Start-/Pause-Taste.

GB

BG

DE

ES

FR

GR

IT

PT

NL

CA

SE

FI

DK

NO

HU

AR

4



4. Als Zweites wählen Sie den unteren Korb. Wählen Sie dann Ihre gewünschte Garmethode, zum Beispiel die Dörrfunktion. Stellen Sie die Zeit und die Temperatur nach Bedarf ein. Zum Schluss drücken Sie die Start-/Pause-Taste.

5

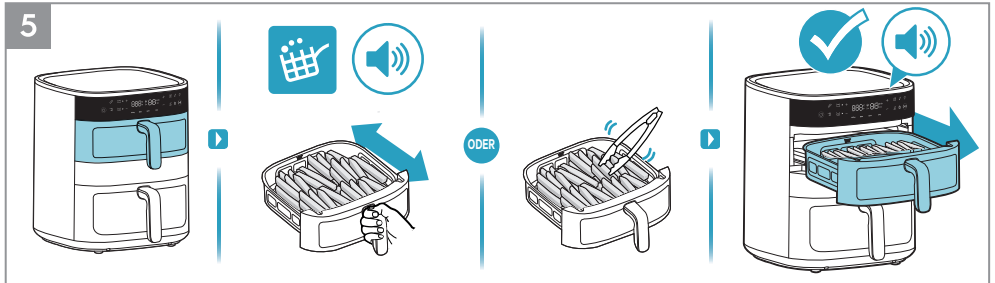

5. Wenn während des Garvorgangs das Symbol "Schüttel-/Wendeerinnerung" aufleuchtet und ein Signalton ertönt, wenden Sie die Speisen mit hitzebeständigen Utensilien einmal oder schütteln Sie den Frittierkorb vorsichtig. Am Ende der Garzeit des oberen Korbs gibt das Gerät einen Signalton ab.

6

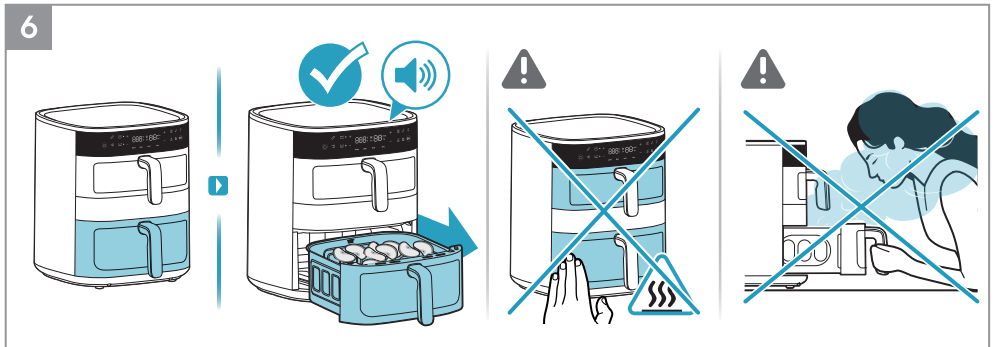

6. Am Ende der Garzeit des unteren Korbs gibt das Gerät einen Signalton ab.

7

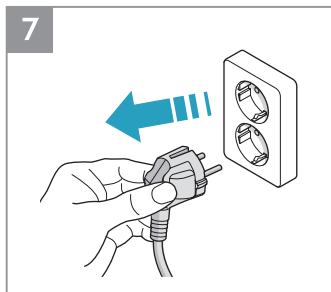

7. Nehmen Sie das Gerät nach der Verwendung vom Strom.

Verwendung - Verbindungsfunktion

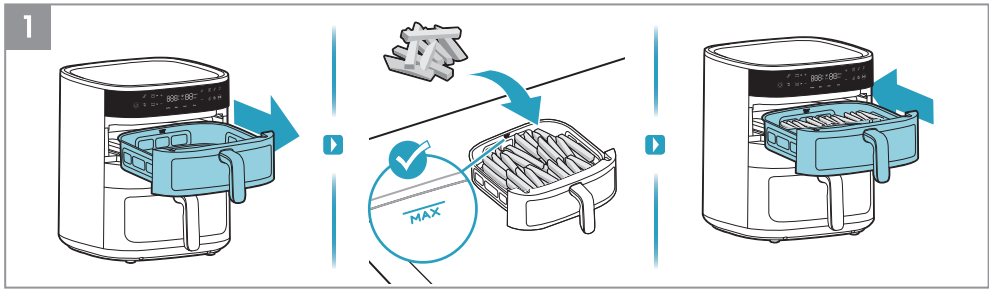

1. Zuerst ziehen Sie den oberen Korb heraus und legen das Gargut in den Korb, zum Beispiel Pommes frites.

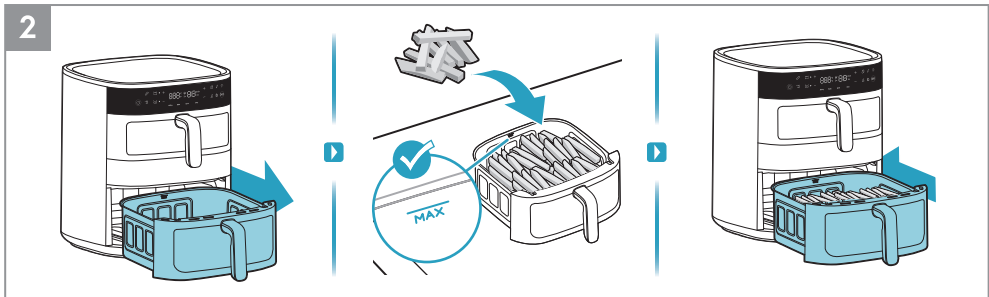

2. Als Zweites ziehen Sie den unteren Korb heraus und legen Sie weiteres Gargut in den Korb, zum Beispiel Pommes frites.



3. Drücken Sie die Ein-/Aus-Taste. Zuerst wählen Sie die Verbindungsfunktion. Dann wählen Sie Ihre gewünschte Garmethode aus, zum Beispiel die Funktion Heißluftfrittieren. Stellen Sie die Zeit und die Temperatur nach Bedarf ein oder wählen Sie eines der voreingestellten Rezepte aus. Zum Schluss drücken Sie die Start-/Pause-Taste.

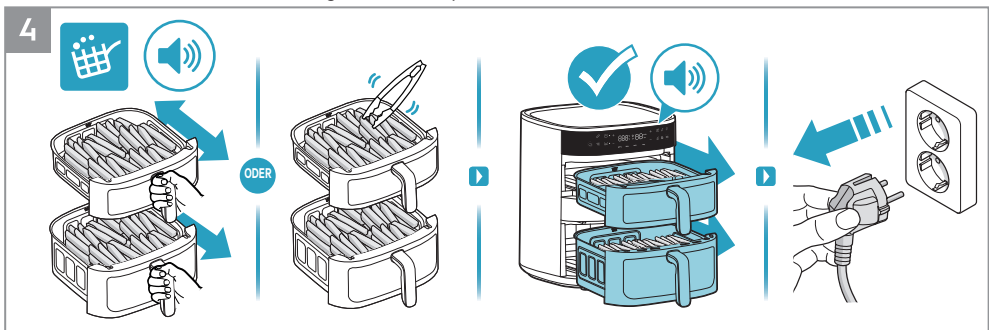

4. Wenn während des Garvorgangs das Symbol "Schüttel-/Wendeerinnerung" aufleuchtet und ein Signalton ertönt, wenden Sie die Speisen mit hitzebeständigen Utensilien einmal oder schütteln Sie den Frittierkorb vorsichtig. Am Ende der Garzeit gibt das Gerät einen Signalton ab. Nehmen Sie das Gerät nach der Verwendung vom Strom.

GB

BG

DE

ES

FR

GR

IT

PT

NL

CA

SE

FI

DK

NO

HU

AR

Verwendung - Sync-End-Funktion

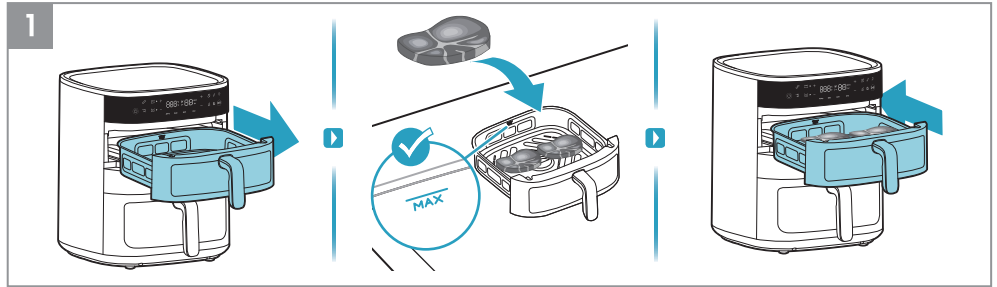

1. Zuerst ziehen Sie den oberen Korb heraus und legen das Gargut in den Korb, zum Beispiel Steak.

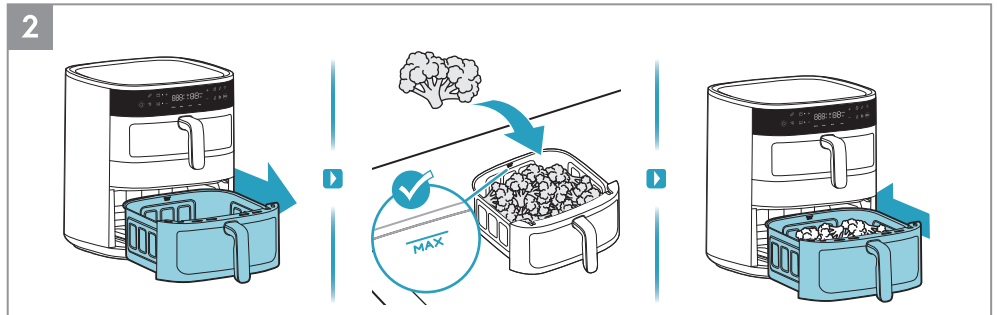

2. Als Zweites ziehen Sie den unteren Korb heraus und legen Sie weiteres Gargut in den Korb, zum Beispiel Brokkoli.



3. Drücken Sie die Ein-/Aus-Taste. Drücken Sie die Sync-End-Funktion. Wählen Sie zuerst den oberen Korb und dann die gewünschte Garmethode, zum Beispiel die Funktion Heißluftfrittieren. Stellen Sie die Zeit und die Temperatur nach Bedarf ein oder wählen Sie eines der voreingestellten Rezepte aus, zum Beispiel "Steak".

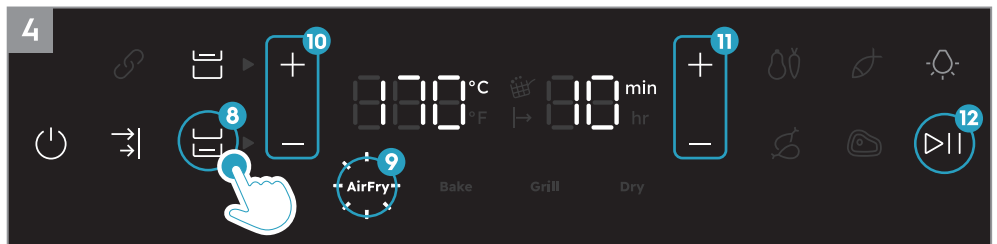

4. Wählen Sie dann den unteren Korb aus und wählen Sie die gewünschte Garmethode, zum Beispiel die Funktion Heißluftfrittieren. Stellen Sie die Zeit und die Temperatur nach Bedarf ein oder wählen Sie eines der voreingestellten Rezepte aus. Zum Schluss drücken Sie die Start-/Pause-Taste.

GB
BG
DE
ES
FR
GR
IT
PT
NL
CA
SE
FI
DK
NO
HU
AR

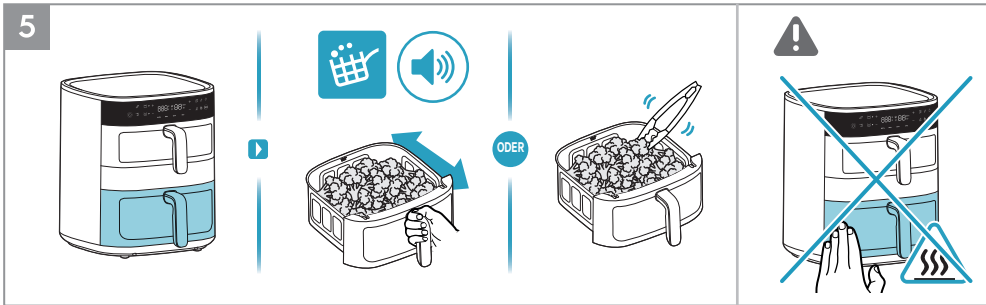

5. Zunächst wird der untere Korb mit längerer Einstellzeit für das Garen priorisiert. Wenn während des Garvorgangs das Symbol „Schüttel-/Wendeerinnerung“ aufleuchtet und ein Signalton ertönt, wenden Sie die Speisen mit hitzebeständigen Utensilien einmal oder schütteln Sie den Frittierkorb vorsichtig.

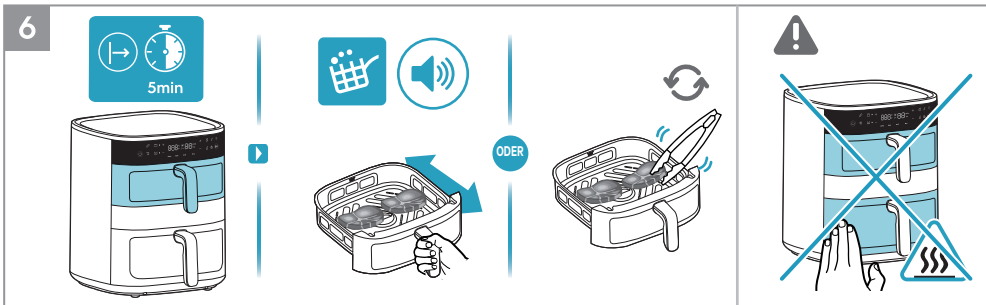

6. Als Zweites beginnt der obere Korb mit kürzerer Einstellzeit mit dem Garen. Wenn während des Garvorgangs das Symbol „Schüttel-/Wendeerinnerung“ aufleuchtet und ein Signalton ertönt, wenden Sie die Speisen mit hitzebeständigen Utensilien einmal oder schütteln Sie den Frittierkorb vorsichtig.

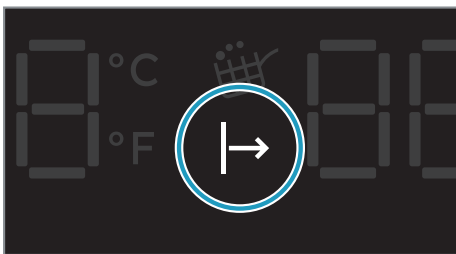

Anzeige "Warten auf das Garen"

Wenn die "Sync-End-Funktion" aktiviert ist, wartet der Korb mit der kürzeren Garzeit mit dem Garvorgang, bis der Korb mit der längeren Garzeit eine Weile gegart hat, sodass beide Körbe gleichzeitig mit dem Garvorgang fertig werden. Während dieser Zeit leuchtet die Anzeige "Warten auf das Garen" auf, bis der Garvorgang beginnt.



7. Am Ende der Garzeit gibt das Gerät einen Signalton ab. Nehmen Sie das Gerät nach der Verwendung vom Strom.

Reinigung

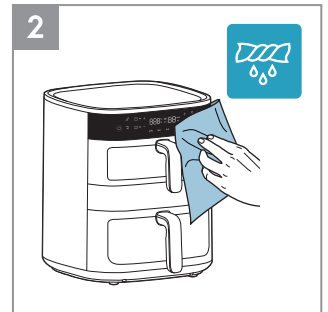
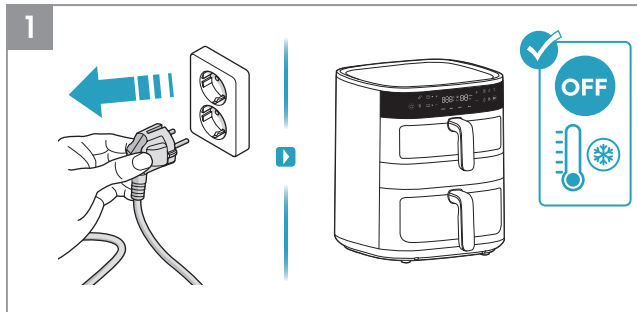

1. Ziehen Sie stets den Netzstecker und warten Sie, bis das Gerät abgekühlt ist, bevor Sie es reinigen.
2. Wischen Sie die Außenseite des Geräts mit einem weichen Tuch ab.

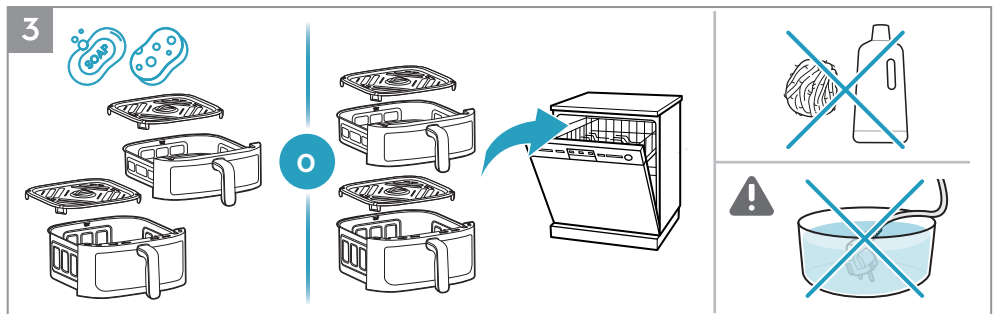

3. Reinigen Sie die Pfanne und den Rösteinsatz mit warmem Wasser und Geschirreiniger oder geben Sie sie in die Spülmaschine.

HINWEIS: Verwenden Sie keine scheuernden Reinigungsmittel oder Metallwerkzeuge, um die Antihftbeschichtung zu schützen.



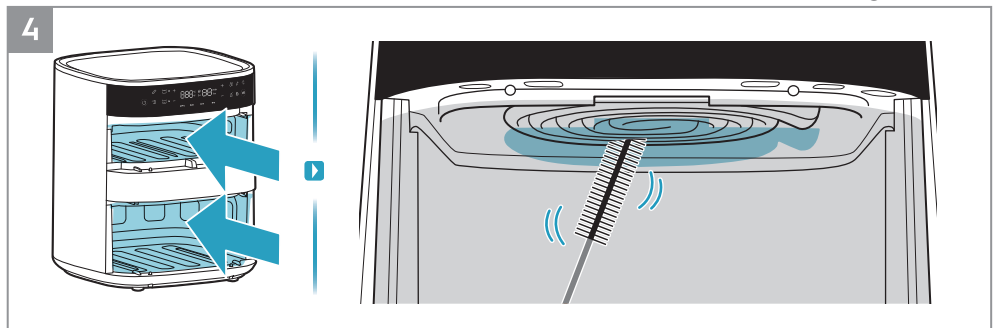









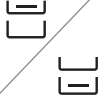















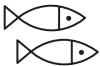









VORSICHT: Tauchen Sie das Produkt, das Kabel oder den Stecker niemals in Wasser oder andere Flüssigkeiten ein.















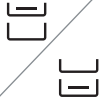













4. Reinigen Sie das Heizelement mit einer Reinigungsbürste.

HINWEIS: Stellen Sie sicher, dass das Gerät vollständig abgekühlt ist, bevor Sie das Heizelement reinigen.

Garanleitung

							
AirFry	7mm/10mm 	4L 	400g	180 °C	18min		
		7L 	400g	180 °C	18min		
AirFry		4L 	400g	170 °C	8min		
		7L 	400g	170 °C	10min		
AirFry		4L 	400g/2Stk.	140 °C	15min		
		7L 	400g/2Stk.	140 °C	15min		
AirFry		4L 	1000g/8Stk.	180 °C	28min		
		7L 	1000g/8Stk.	180 °C	28min		
AirFry		4L 	400g/2Stk.	200 °C	10min		
		7L 	400g/2Stk.	200 °C	10min		
AirFry		4L 	220g/6cm	160 °C	12min		
		7L 	220g/6cm	160 °C	14min		

- GB
- BG
- DE**
- ES
- FR
- GR
- IT
- PT
- NL
- CA
- SE
- FI
- DK
- NO
- HU
- AR

							
AirFry		 7L	1200g	180 °C	55min		
AirFry		 7L	400g/9Stk.	160 °C	20min		
Grill		 4L	180g/4Stk.	180 °C	8min		
Grill		 7L	180g/4Stk.	180 °C	9min		
Dry		 4L	180g	80 °C	3h		
Dry		 7L	180g	80 °C	3h		
Dry		 4L	200g	80 °C	3h		
Dry		 7L	200g	80 °C	3h		

GB

BG

DE

ES

FR

GR

IT

PT

NL

CA

SE

FI

DK

NO

HU

AR

Was tun, wenn...

Problem	Überprüfen Sie, ob...
Sie können das Gerät nicht starten oder bedienen.	<ul style="list-style-type: none"> • Das Gerät ist korrekt an die Stromversorgung angeschlossen. • Die Körbe sind in der richtigen Position. Stellen Sie sicher, dass sie vollständig in das Gerät eingeschoben sind, um die Stromversorgung zu aktivieren. • Die Garzeit ist eingestellt.
Sie können den Korb nicht in das Gerät hineinschieben.	<ul style="list-style-type: none"> • Der Korb ist über seine maximale Kapazität hinaus gefüllt. • Der Korb ist richtig hineingeschoben. Er muss einrasten, wenn Sie ihn in das Gerät einschieben. • Unter dem Korb befindet sich ein Gegenstand, der das vollständige Schließen verhindert.
Weißer Rauch kommt aus dem Gerät.	<ul style="list-style-type: none"> • Das Gargut, das Sie zubereiten, ist zu fettig. • Der Korb, der Rösteinsatz und das Heizelement sind sauber.
Das Display zeigt "E1" an.	<ul style="list-style-type: none"> • Unterbrochener Stromkreis oberer Korb.
Das Display zeigt "E2" an.	<ul style="list-style-type: none"> • Kurzschluss oberer Korb.
Das Display zeigt "E3" an.	<ul style="list-style-type: none"> • Unterbrochener Stromkreis unterer Korb.
Das Display zeigt "E4" an.	<ul style="list-style-type: none"> • Kurzschluss unterer Korb.
Das Display zeigt "E5" an.	<ul style="list-style-type: none"> • Kommunikationsfehler der Steuerungs-PCBA.
Das Display zeigt "E6" an.	<ul style="list-style-type: none"> • Kommunikationsfehler der Power-PCBA.

* Wenn auf dem Display Fehlercodes angezeigt werden, muss das Gerät von einem Servicecenter repariert werden.

Technische Daten

Produkt	Heißluftfritteuse
Modell	AAFD11B
Volt (V)	220 V ~ 240 V
Leistung (W)	2700 W
Frequenz (Hz)	50 ~ 60 Hz
Kapazität	4 L + 7 L

GB

BG

DE

ES

FR

GR

IT

PT

NL

CA

SE

FI

DK

NO

HU

AR



Libro de instrucciones

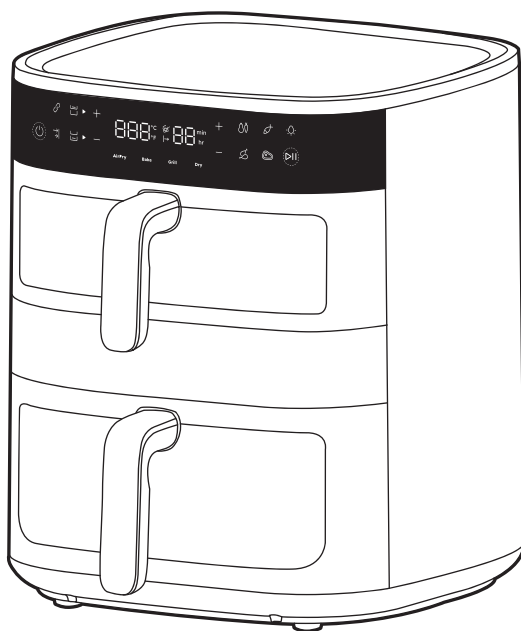

800 Freidora de aire Dual

Vista general

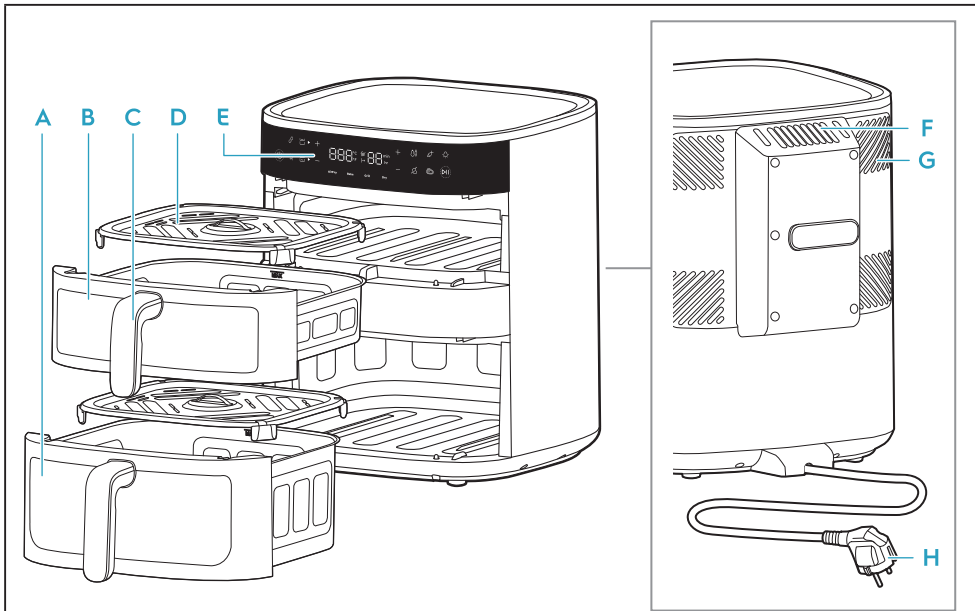

- | | | | |
|------------------------------------|--------------------------|---------------------------|-----------------------------------|
| A Cesta inferior (7 litros) | C Asa de la cesta | E Panel de control | G Sistema de refrigeración |
| B Cesta superior (4 litros) | D Rejilla | F Salida de aire | H Cable de alimentación |

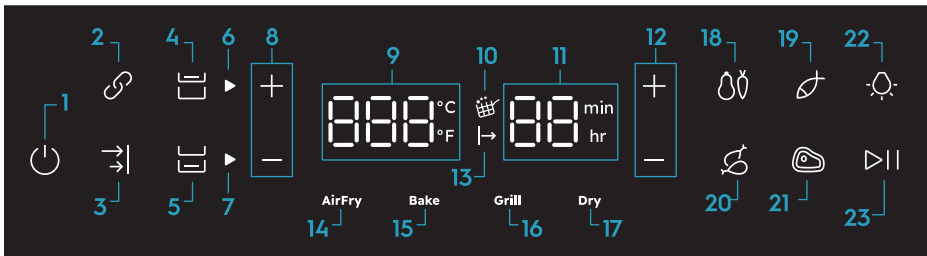

- | | | | |
|---|--|---------------------------------|--------------------|
| 1. Encendido/Apagado | 8. Control de temperatura | 12. Control de tiempo | 21. Filete |
| 2. Función de enlace | 9. Indicador de temperatura (40-200 °C) | 13. Espera para la cocción | 22. Control de luz |
| 3. Función de finalización sincronizada | 10. Recordatorio de remover | 14. Función de freidora de aire | 23. Iniciar/Pausar |
| 4. Control de la cesta superior | 11. Indicador de tiempo (Freidora de aire: 1-99 min, Deshidratar: 1-5 h) | 15. Función de hornear | |
| 5. Control de la cesta inferior | | 16. Función de grill | |
| 6. Indicador de la cesta superior | | 17. Función de deshidratar | |
| 7. Indicador de la cesta inferior | | 18. Verduras | |
| | | 19. Pescado | |
| | | 20. Pollo | |

GB

BG

DE

ES

FR

GR

IT

PT

NL

CA

SE

FI

DK

NO

HU

AR

Antes del primer uso

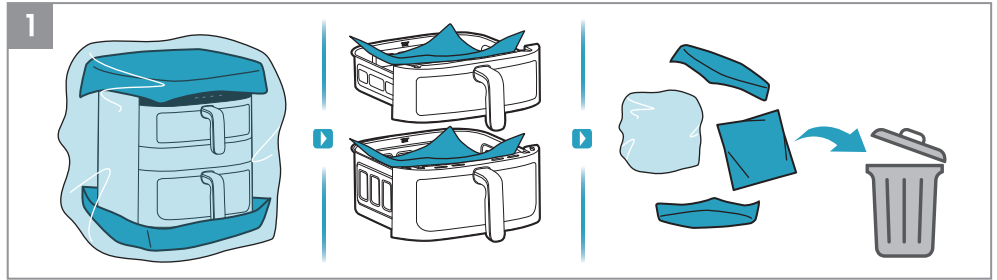

1. Retire todo el embalaje y el material protector.

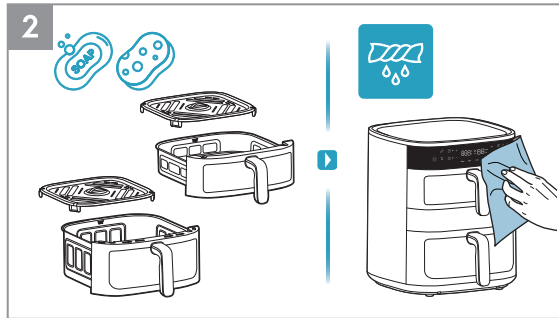

2. Limpie la bandeja y la rejilla con agua tibia y detergente para platos. Limpie el interior y el exterior del aparato con un paño suave.

3. Es normal que un aparato nuevo emita olores las primeras veces que se utiliza. Asegúrese de que la freidora de aire esté vacía y déjela funcionar a 200 °C durante 20 minutos antes del primer uso para evitar esto.

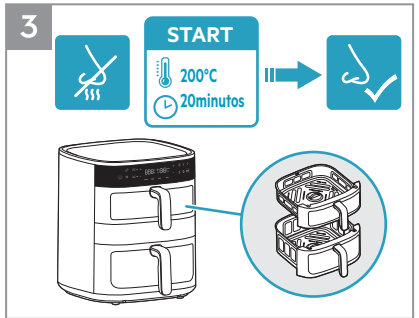

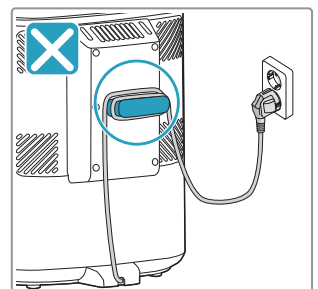
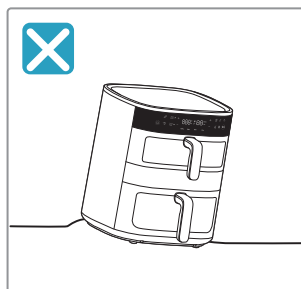
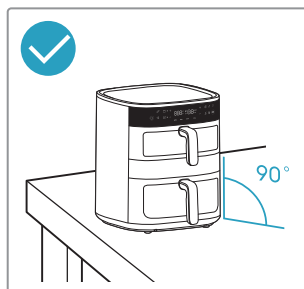
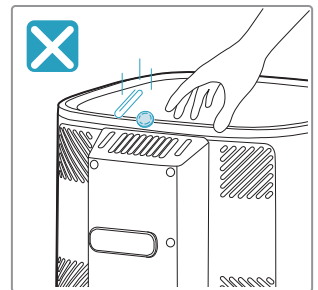
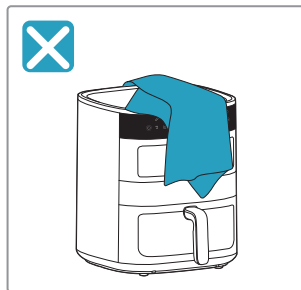
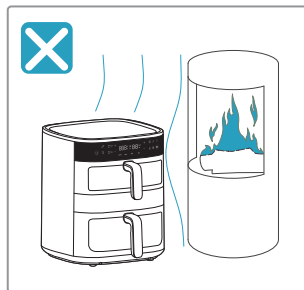

! Precauciones de seguridad





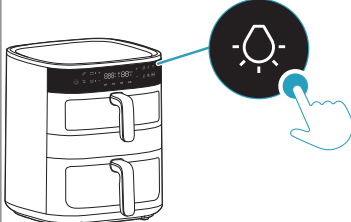
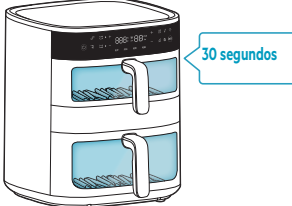

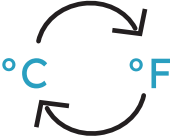



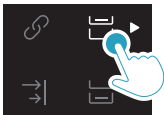





GB
BG
DE
ES
FR
GR
IT
PT
NL
CA
SE
FI
DK
NO
HU
AR

Control de luz y conversión de la escala de temperatura





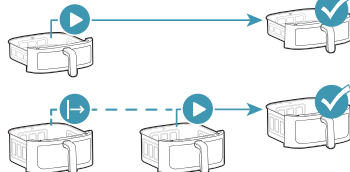









 <p>Control de luz</p>		 <p>30 segundos</p>
<p>°C/°F</p> <p>Conversión de la escala de temperatura</p>	 <p>30 segundos</p>	

Selección de la cesta

	 <p>4 litros</p>	 <p>7 litros</p>	
 <p>Cesta superior</p>			
 <p>Cesta inferior</p>			
 <p>Función de enlace</p>			
 <p>Función de finalización sincronizada</p>			

- GB
- BG
- DE
- ES
- FR
- GR
- IT
- PT
- NL
- CA
- SE
- FI
- DK
- NO
- HU
- AR

Funciones predefinidas

 Air Fry					
Air Fry	180°C	15 minutos	60-200°C	1-99min	
	170°C	10 minutos	60-200°C	1-99min	
	140°C	15 minutos	60-200°C	1-99min	
	180°C	30 minutos	60-200°C	1-99 minutos	
	200°C	10 minutos	60-200°C	1-99 minutos	
Bake	170°C	15 minutos	60-200°C	1-99 minutos	
Grill	200°C	5 minutos	60-200°C	1-99 minutos	
Dry	80°C	5 horas	40-80°C	1-5 horas	

Antes de cocinar

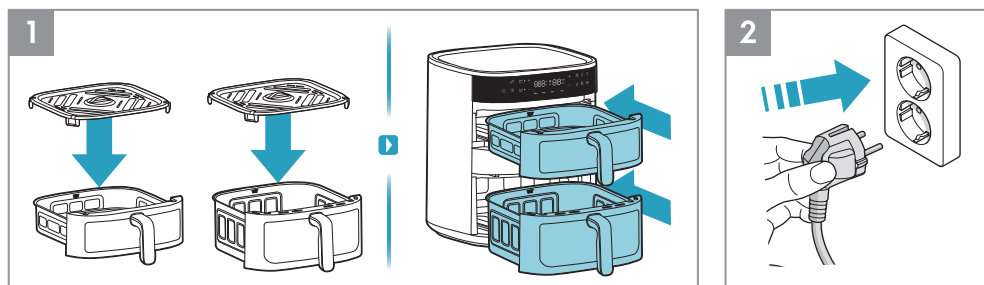

1. Antes de cada cocción, coloque la rejilla dentro de la cesta (no es necesario retirar los soportes de silicona resistentes al calor de la rejilla) e introduzca completamente la cesta en el aparato.
2. Conecte el enchufe a la toma de corriente.

Cómo usar – Cesta única

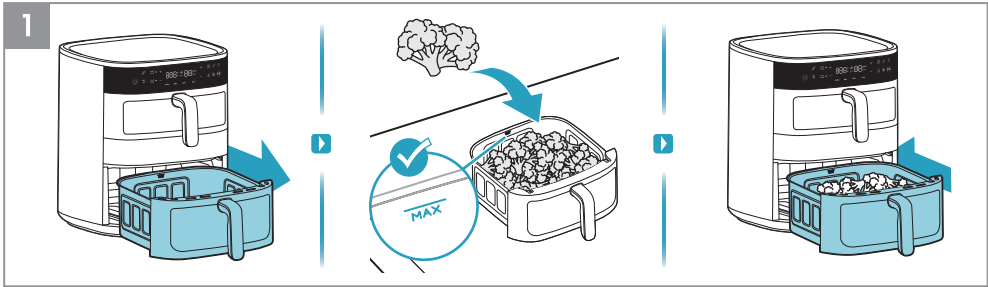

1. Saque una cesta y colóquela sobre una superficie estable; ponga los alimentos en la cesta respetando la indicación de capacidad "MAX.". A continuación, introduzca completamente la cesta con los alimentos en el aparato.

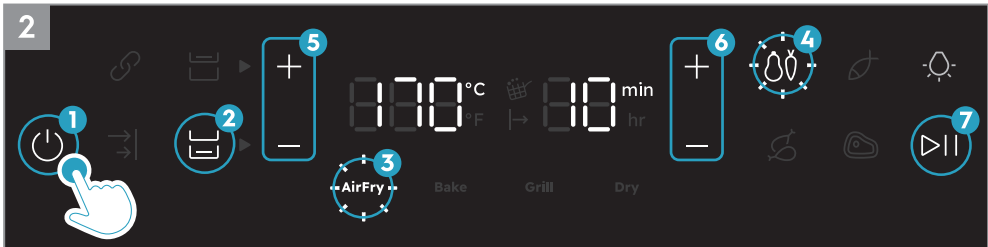

2. Pulse el botón Encendido/Apagado. Primero seleccione la cesta con los alimentos. A continuación, seleccione el método de cocción que quiera, por ejemplo la función freidora de aire. Ajuste el tiempo y la temperatura a su gusto o seleccione una de las recetas predefinidas, por ejemplo, Verduras. Por último, pulse el botón Iniciar/Pausar.

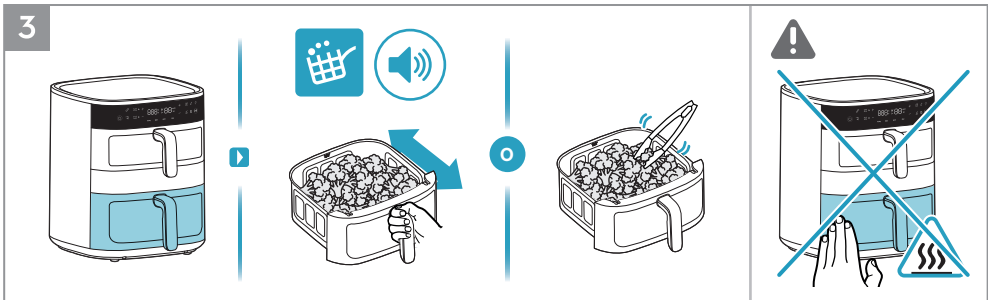

3. Cuando el icono "Recordatorio de remover" se ilumine y emita un pitido durante el proceso de cocción, utilice utensilios resistentes al calor para dar la vuelta a los alimentos una vez o remueva suavemente los alimentos en la cesta de freír.

⚠ **PRECAUCIÓN:** No agite o remueva la cesta de freír con fuerza para evitar que los alimentos salpiquen y puedan causar quemaduras.

⚠ **PRECAUCIÓN:** Tenga cuidado con las superficies calientes cuando el aparato esté en funcionamiento.

Recordatorio de remover

El "Recordatorio de remover" se activa durante la función freidora de aire y en las recetas predefinidas, como Verduras, Pescado, Muslos de pollo y Filete.

Cuando llegue el momento de remover o dar la vuelta a los alimentos, el icono "Recordatorio de remover" se iluminará y parpadeará durante un minuto, mientras que la señal acústica sonará tres veces.

El "Recordatorio de remover" no es obligatorio; la cocción continuará con normalidad aunque no se remuevan o se de la vuelta a los alimentos.

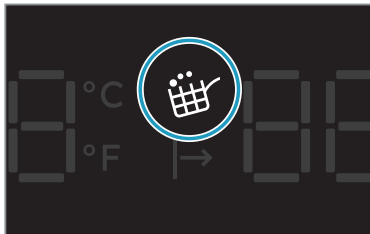

GB

BG

DE

ES

FR

GR

IT

PT

NL

CA

SE

FI

DK

NO

HU

AR

4

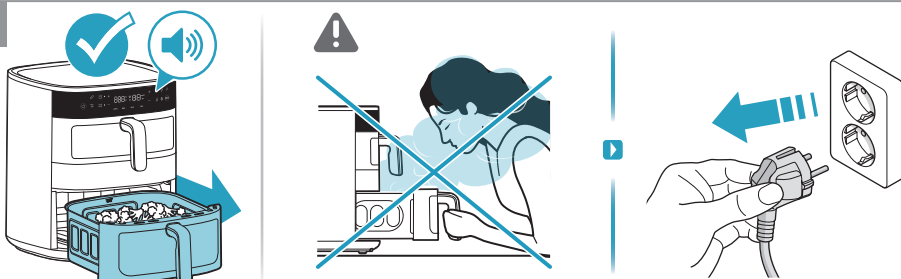

4. Al finalizar el tiempo de cocción, el aparato emitirá una señal acústica. Retire la cesta con cuidado y colóquela sobre una superficie resistente al calor. Desenchufe el aparato después de utilizarlo.

⚠ **PRECAUCIÓN:** Puede salir vapor caliente de la cesta cuando se abre durante la cocción o al finalizarla. Mantenga la cara, los brazos y las manos alejados del vapor al abrirla.

Cómo usar – Cesta superior + cesta inferior

1

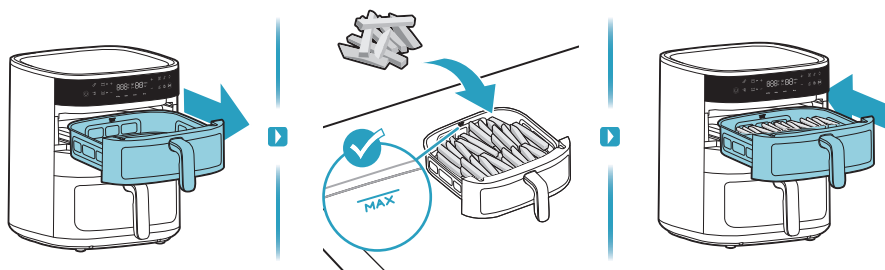

1. Primero, saque la cesta superior y coloque los alimentos en la cesta, por ejemplo patatas fritas.

2

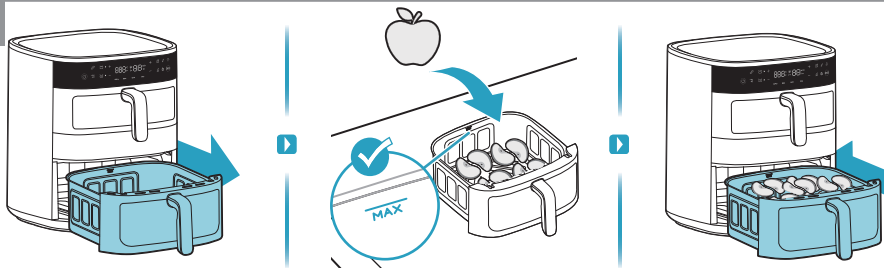

2. En segundo lugar, saque la cesta inferior y coloque los alimentos en la cesta, por ejemplo rodajas de manzana.

3



3. Pulse el botón Encendido/Apagado. Primero seleccione la cesta superior. A continuación, seleccione el método de cocción que quiera, por ejemplo la función freidora de aire. Ajuste el tiempo y la temperatura a su gusto o seleccione una de las recetas predefinidas, por ejemplo, Verduras. Por último, pulse el botón Iniciar/Pausar.

GB

BG

DE

ES

FR

GR

IT

PT

NL

CA

SE

FI

DK

NO

HU

AR



4. A continuación seleccione la cesta inferior. Después seleccione el método de cocción deseado, por ejemplo la función de deshidratar. Ajuste el tiempo y la temperatura a su gusto. Por último, pulse el botón Iniciar/Pausar.

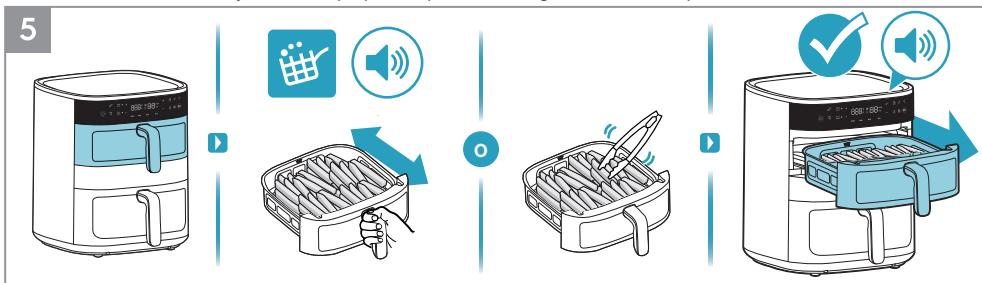

5. Cuando el icono "Recordatorio de remover" se ilumine y emita un pitido durante el proceso de cocción, utilice utensilios resistentes al calor para dar la vuelta a los alimentos una vez o remueva suavemente los alimentos en la cesta de freír. Al finalizar el tiempo de cocción de la cesta superior, el aparato emitirá una señal acústica.

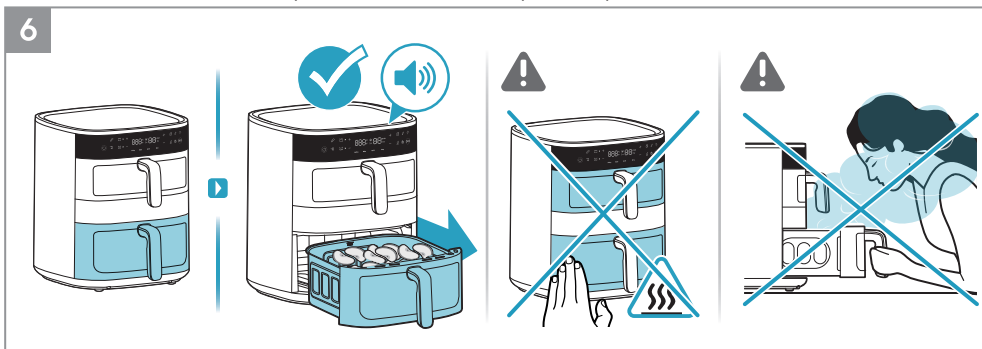

6. Al finalizar el tiempo de cocción de la cesta inferior, el aparato emitirá una señal acústica.

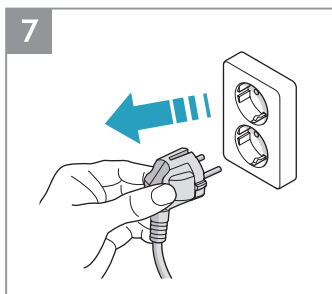

7. Desenchufe el aparato después de utilizarlo.

GB
BG
DE
ES
FR
GR
IT
PT
NL
CA
SE
FI
DK
NO
HU
AR

Cómo usar – Función de enlace

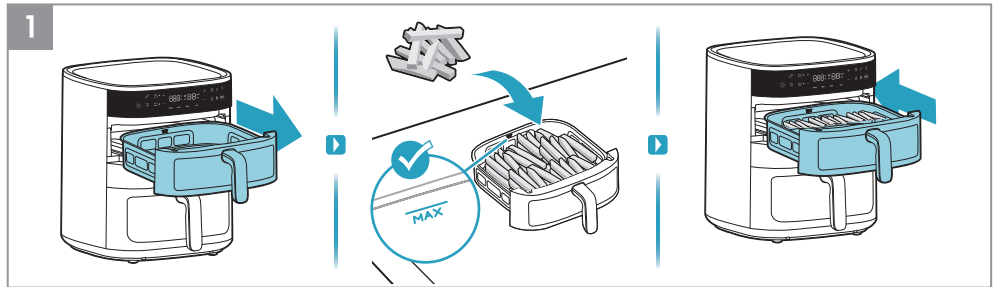

1. Primero, saque la cesta superior y coloque los alimentos en la cesta, por ejemplo patatas fritas.

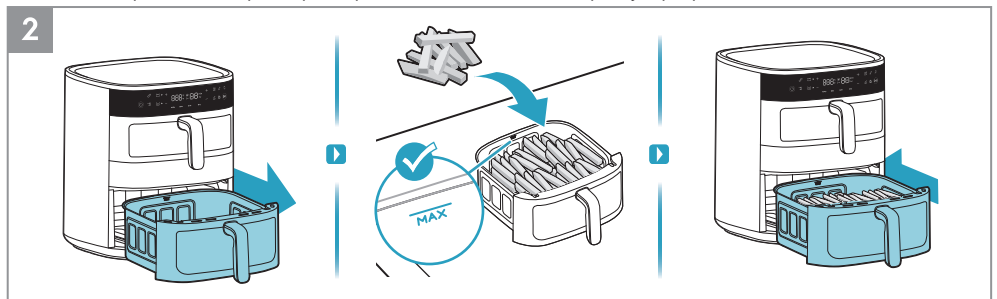

2. En segundo lugar, saque la cesta inferior y coloque los alimentos en la cesta, por ejemplo patatas fritas.



3. Pulse el botón Encendido/Apagado. Primero seleccione la función de enlace. A continuación, seleccione el método de cocción que quiera, por ejemplo la función freidora de aire. Ajuste el tiempo y la temperatura a su gusto o seleccione una de las recetas predefinidas. Por último, pulse el botón Iniciar/Pausar.

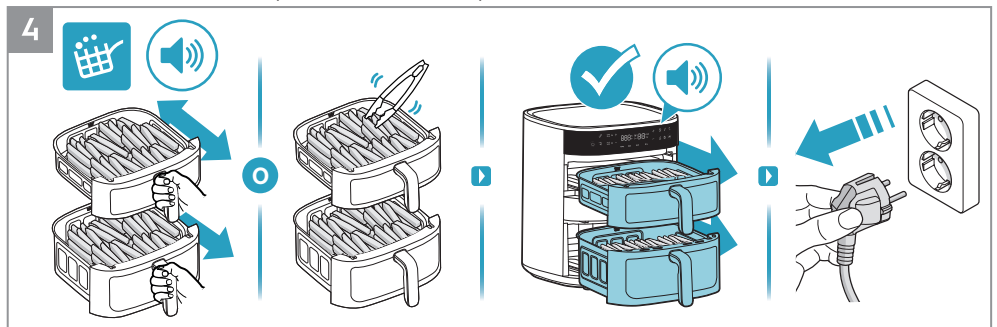

4. Cuando el icono «Recordatorio de remover» se ilumine y emita un pitido durante el proceso de cocción, utilice utensilios resistentes al calor para dar la vuelta a los alimentos una vez o remueva suavemente los alimentos en la cesta de freír. Al finalizar el tiempo de cocción, el aparato emitirá una señal acústica. Desenchufe el aparato después de utilizarlo.

Cómo usar – Función de finalización sincronizada

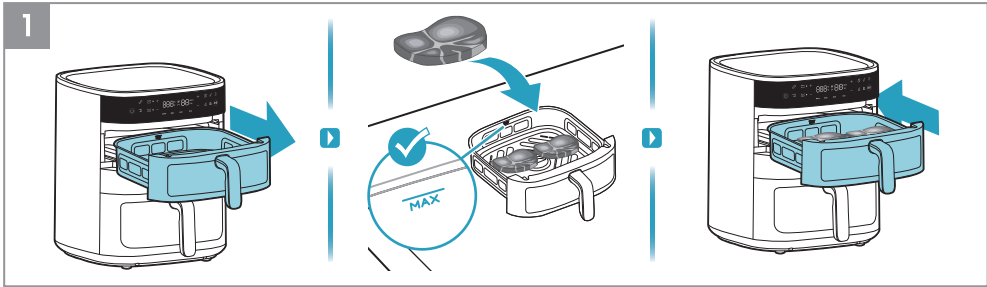

1. Primero, saque la cesta superior y coloque los alimentos en la cesta, por ejemplo un filete.

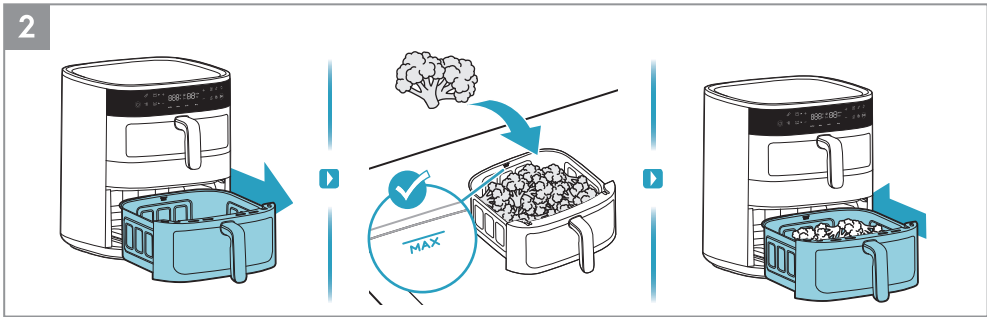

2. En segundo lugar, saque la cesta inferior y coloque los alimentos en la cesta, por ejemplo brócoli.

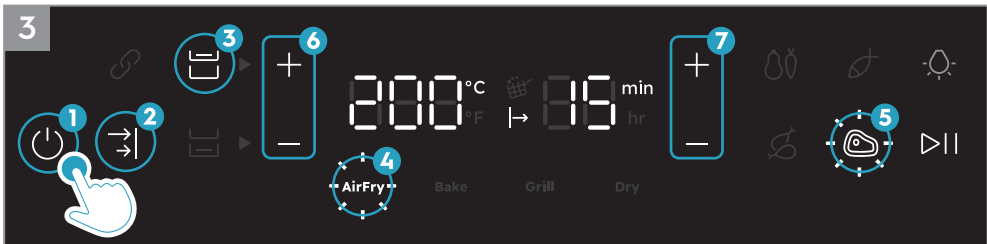

3. Pulse el botón Encendido/Apagado. Seleccione la función de finalización sincronizada. Primero seleccione la cesta superior y después el método de cocción deseado, por ejemplo, la función freidora de aire. Ajuste el tiempo y la temperatura a su gusto o seleccione una de las recetas predefinidas, por ejemplo Filete.

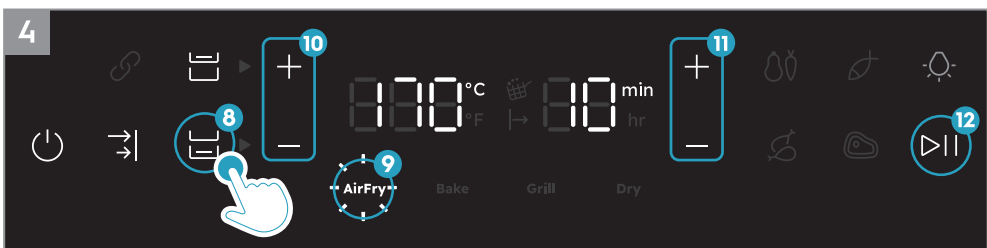

4. A continuación seleccione la cesta inferior y el método de cocción deseado, por ejemplo la función freidora de aire. Ajuste el tiempo y la temperatura a su gusto o seleccione una de las recetas predefinidas. Por último, pulse el botón Iniciar/Pausar.

GB

BG

DE

ES

FR

GR

IT

PT

NL

CA

SE

FI

DK

NO

HU

AR

5

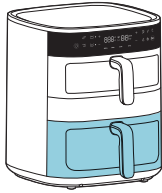

5. Primero, la cesta inferior con el tiempo de cocción más largo se iniciará antes. Cuando el icono “Recordatorio de remover” se ilumine y emita un pitido durante el proceso de cocción, utilice utensilios resistentes al calor para dar la vuelta a los alimentos una vez o remueva suavemente los alimentos en la cesta de freír.

6

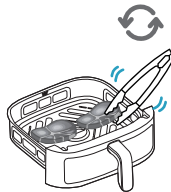
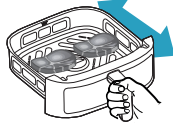
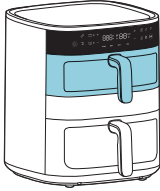

6. Después, la cesta superior con el tiempo de cocción más corto comenzará la cocción. Cuando el icono “Recordatorio de remover” se ilumine y emita un pitido durante el proceso de cocción, utilice utensilios resistentes al calor para dar la vuelta a los alimentos una vez o remueva suavemente los alimentos en la cesta de freír.

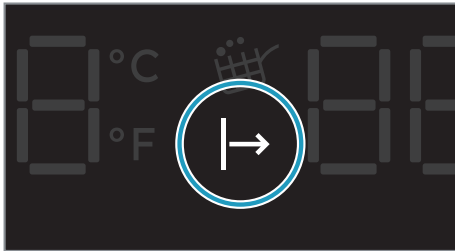

Indicador de espera para la cocción

Cuando la “función de finalización sincronizada” está activada, la cesta con el tiempo de cocción más corto esperará antes de comenzar hasta que la cesta con el tiempo de cocción más largo lleve un tiempo cocinando, de modo que ambas cestas finalicen la cocción al mismo tiempo. Durante este periodo, el “indicador de espera para la cocción” permanecerá encendido hasta que comience la cocción.

7

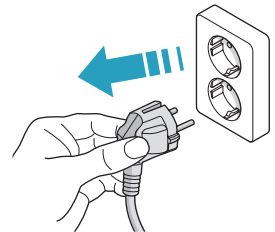
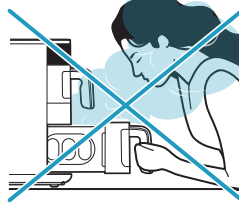

7. Al finalizar el tiempo de cocción, el aparato emitirá una señal acústica. Desenchufe el aparato después de utilizarlo.

Limpeza

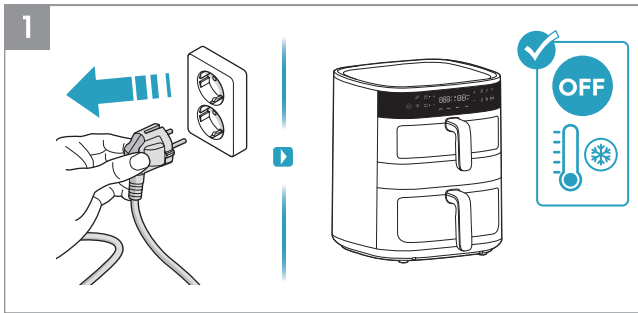

1. Desenchufe siempre el aparato y espere a que se enfríe antes de limpiarlo.
2. Limpie el exterior del aparato con un paño suave.

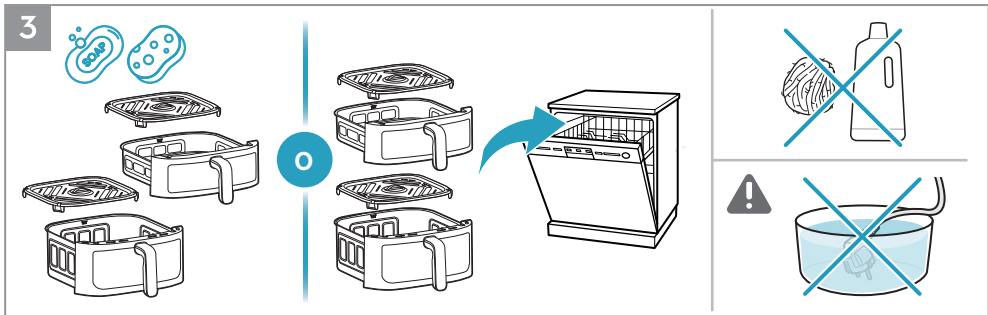
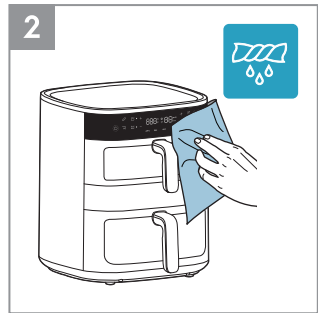

3. Limpie la bandeja y la rejilla con agua tibia y detergente para platos, o colóquelas en el lavavajillas.

NOTA: Evite utilizar productos de limpieza abrasivos o utensilios metálicos para proteger el revestimiento antiadherente.

PRECAUCIÓN: Nunca sumerja el producto, el cable o el enchufe en agua ni en ningún otro líquido.

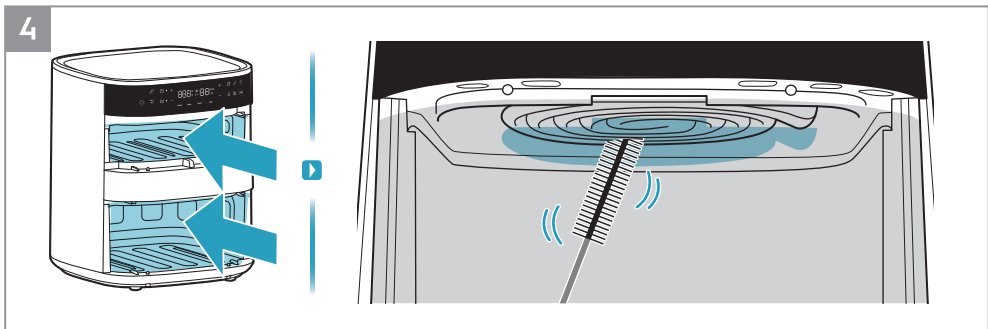

4. Limpie el elemento calefactor con un cepillo de limpieza.

NOTA: Asegúrese de que el aparato esté completamente frío antes de limpiar el elemento calefactor.

Guía de cocción

GB

BG

DE

ES

FR

GR

IT

PT

NL

CA

SE













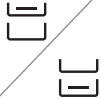































FI

DK

























NO

HU

AR

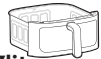
							
	7mm/10mm 	 4 litros	400g	180 °C	18min		
		 7 litros	400g	180 °C	18min		
		 4 litros	400g	170 °C	8min		
		 7litros	400g	170 °C	10min		
		 4litros	400g/2unidades	140 °C	15min		
		 7litros	400g/2unidades	140 °C	15min		
		 4litros	1000g/8unidades	180 °C	28min		
		 7litros	1000g/8unidades	180 °C	28min		
		 4litros	400g/2unidades	200 °C	10min		
		 7litros	400g/2unidades	200 °C	10min		
		 4litros	220g/6pulgadas	160 °C	12min		
		 7litros	220g/6pulgadas	160 °C	14min		

GB
 BG
 DE
ES
 FR
 GR
 IT
 PT
 NL
 CA
 SE
 FI
 DK
 NO
 HU
 AR

							
AirFry		 7litros	1200g	180 °C	55min		
AirFry		 7litros	400g/9unidades	160 °C	20min		
Grill		 4litros	180g/4unidades	180 °C	8min		
		 7litros	180g/4unidades	180 °C	9min		
Dry		 4litros	180g	80 °C	3h		
		 7litros	180g	80 °C	3h		
Dry		 4litros	200g	80 °C	3h		
		 7litros	200g	80 °C	3h		

- GB
- BG
- DE
- ES**
- FR
- GR
- IT
- PT
- NL
- CA
- SE
- FI
- DK
- NO
- HU
- AR

Qué hacer si...

Problema	Compruebe si...
No puede activar ni utilizar el aparato.	<ul style="list-style-type: none"> • El aparato está correctamente conectado al suministro eléctrico. • Las cestas están en la posición correcta. Compruebe que estén completamente introducidas en el aparato para permitir el suministro eléctrico. • El tiempo de cocción está configurado.
No puede introducir la cesta en el aparato.	<ul style="list-style-type: none"> • La cesta está llena por encima de su capacidad máxima. • La cesta está colocada correctamente. Debe hacer clic al colocarla en el aparato. • Hay un objeto debajo de la cesta que impide cerrarla correctamente.
Sale humo blanco del aparato.	<ul style="list-style-type: none"> • Los alimentos que está preparando son demasiado grasos. • La cesta, la rejilla y el elemento calefactor están limpios.
La pantalla muestra E1.	<ul style="list-style-type: none"> • Circuito abierto de la cesta superior.
La pantalla muestra E2.	<ul style="list-style-type: none"> • Circuito corto de la cesta superior.
La pantalla muestra E3.	<ul style="list-style-type: none"> • Circuito abierto de la cesta inferior.
La pantalla muestra E4.	<ul style="list-style-type: none"> • Circuito corto de la cesta inferior.
La pantalla muestra E5.	<ul style="list-style-type: none"> • Error de comunicación del PCBA de control.
La pantalla muestra E6.	<ul style="list-style-type: none"> • Error de comunicación del PCBA de alimentación.

* En caso de que la pantalla muestre códigos de error, el aparato debe ser reparado por el Servicio Técnico.

Datos técnicos

Producto	Freidora de aire
Modelo	AAFD11B
Voltaje (V~)	220 V ~ 240 V
Potencia (W)	2700 W
Frecuencia (Hz)	50 ~ 60 Hz
Capacidad	4 L + 7 L

GB

BG

DE

ES

FR

GR

IT

PT

NL

CA

SE

FI

DK

NO

HU

AR



Notice d'utilisation

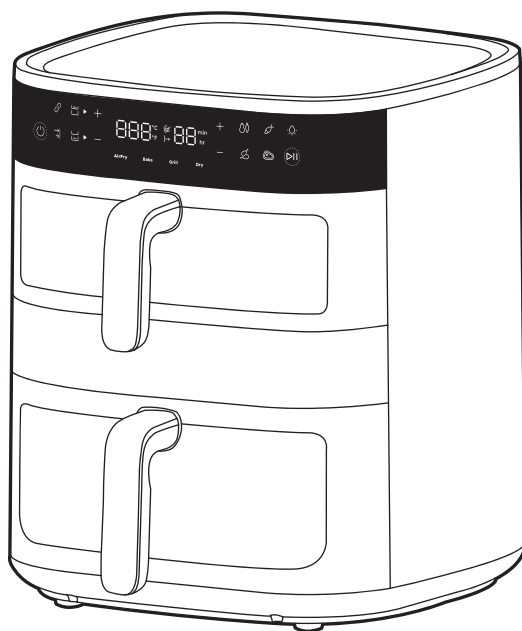

800 Friteuse à l'air chaud double

Présentation générale

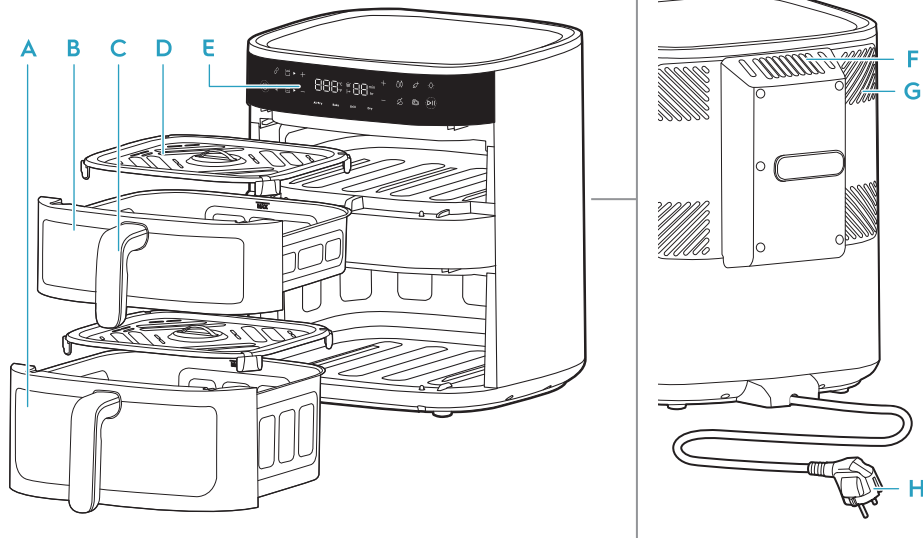

- | | | | |
|--------------------------------|----------------------------|------------------------------|-------------------------------------|
| A Panier inférieur (7L) | C Poignée du panier | E Panneau de commande | G Système de refroidissement |
| B Panier supérieur (4L) | D Grille | F Sortie d'air | H Cordon principal |

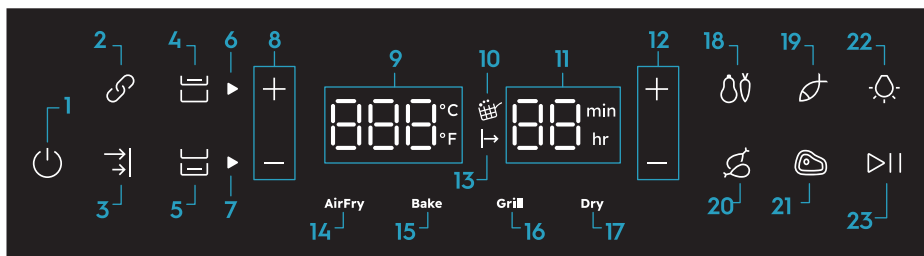

- | | | | |
|---------------------------------------|--|---------------------------------------|--------------------------|
| 1. Activé/Désactivé | 9. TIndicateur de température (40-200 °C) | 13. En attente de cuisson | 20. Poulets |
| 2. Fonction de liaison | 10. Rappel de secouer | 14. Fonction de friture à l'air chaud | 21. Biftèque |
| 3. Fonction de fin de synchronisation | 11. Indicateur du temps (Friture à l'air chaud : 1-99 min, Sécher : 1-5 h) | 15. Fonction de cuisson au four | 22. Contrôle d'éclairage |
| 4. Contrôle du panier supérieur | 12. Contrôle du temps | 16. Fonction grill | 23. Lecture/Pause |
| 5. Contrôle du panier inférieur | | 17. Fonction de séchage | |
| 6. Indicateur de panier supérieur | | 18. Légumes | |
| 7. Indicateur de panier inférieur | | 19. Poisson | |
| 8. Contrôle de température | | | |

GB
BG
DE
ES
FR
GR
IT
PT
NL
CA
SE
FI
DK
NO
HU
AR

Avant la première utilisation

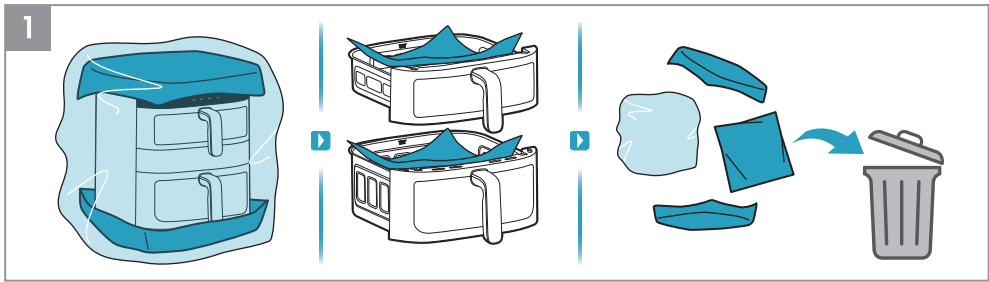

1. Retirez tout l'emballage et le matériel de protection.

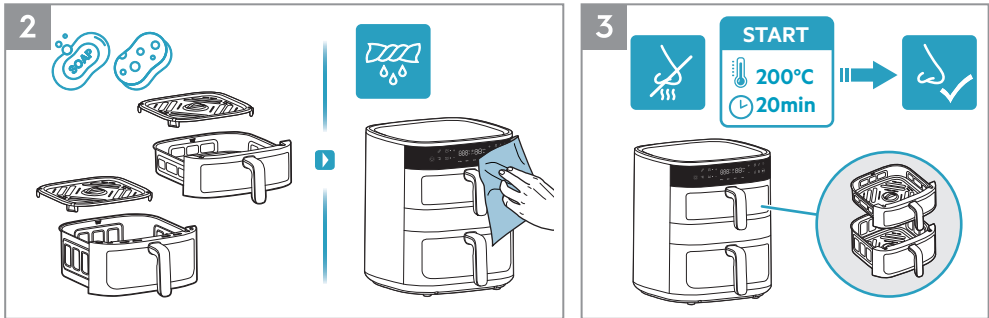

2. Nettoyez la poêle et la grille à l'eau chaude et au liquide vaisselle. Essuyez l'intérieur et l'extérieur de l'appareil avec un chiffon doux.

3. Il est normal qu'un nouvel appareil dégage des odeurs lors des premières utilisations. Pour éviter cela, faites fonctionner la friteuse à l'air chaud vide à 200 °C pendant 20 minutes avant la première utilisation.



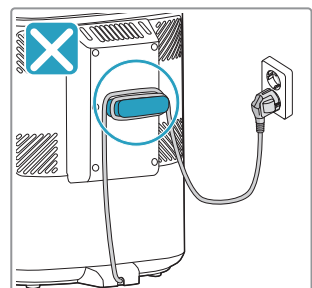
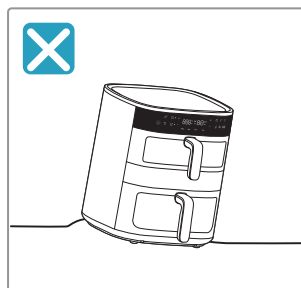
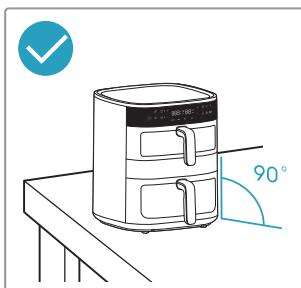
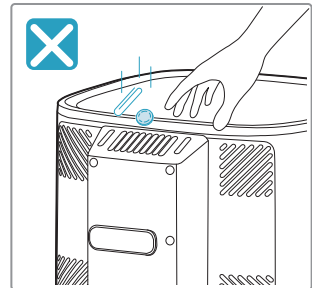
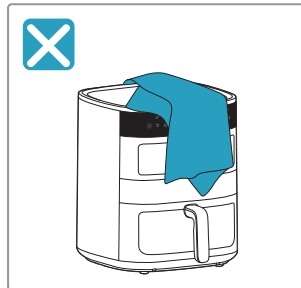
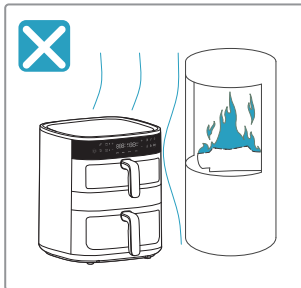



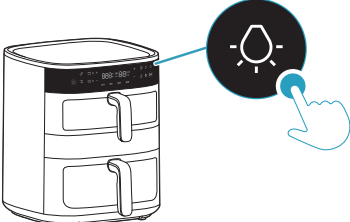
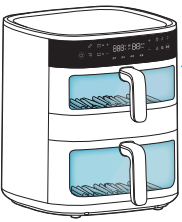
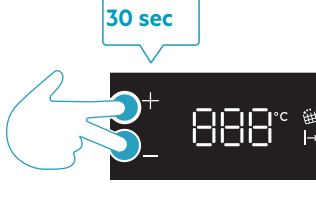
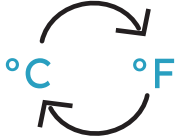



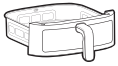

! Précautions de sécurité



Contrôle de l'éclairage et conversion de l'échelle de température





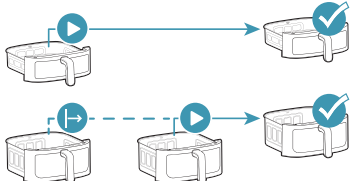









 <p>Contrôle de l'éclairage</p>		 <p>30 sec</p>
<p>°C/°F</p> <p>Conversion de l'échelle de température</p>	 <p>30 sec</p>	

Sélection du panier

	 <p>4L</p>	 <p>7L</p>	
 <p>Panier supérieur</p>			
 <p>Panier inférieur</p>			
 <p>Fonction de liaison</p>			
 <p>Fonction de fin de synchronisation</p>			

GB
BG
DE
ES
FR
GR
IT
PT
NL
CA
SE
FI
DK
NO
HU
AR

Fonctions prédéfinies

 AirFry					
AirFry	180°C	15min	60~200°C	1-99min	
	170°C	10min	60~200°C	1-99min	
	140°C	15min	60~200°C	1-99min	
	180°C	30min	60~200°C	1-99min	
	200°C	10min	60~200°C	1-99min	
Bake	170°C	15min	60~200°C	1-99min	
Grill	200°C	5min	60~200°C	1-99min	
Dry	80°C	5h	40~80°C	1-5h	

Avant la cuisson

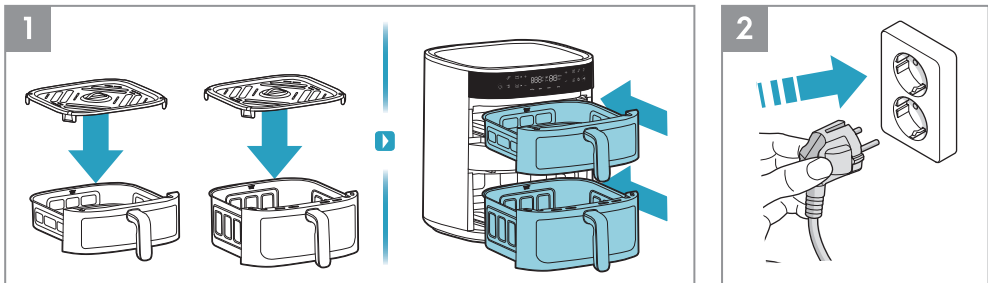

1. Avant chaque cuisson, veuillez placer la grille dans le panier (vous n'avez pas besoin de retirer le coussinet plantaire en silicone résistant à la chaleur de la grille) et enfoncer complètement le panier dans l'appareil.
2. Insérer la fiche dans la prise.

GB

BG

DE

ES

FR

GR

IT

PT

NL

CA

SE

FI

DK

NO

HU

AR

Mode d'emploi - Panier unique

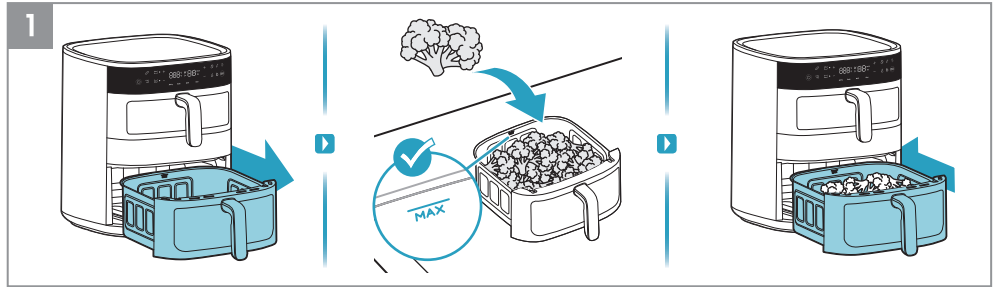

1. Retirez un panier et placez-le sur une surface stable, mettez les aliments dans le panier en respectant l'indication de capacité " MAX. ". Ensuite, repoussez complètement le panier contenant les aliments dans l'appareil.

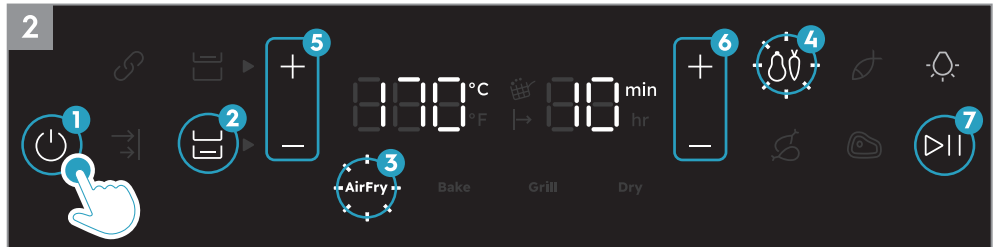

2. Appuyez sur le bouton Activé/Désactivé. Sélectionnez d'abord le panier contenant les aliments. Sélectionnez ensuite le mode de cuisson souhaité, par exemple la fonction de Friture à l'air chaud. Réglez le temps et la température selon vos préférences ou sélectionnez l'une des recettes prédéfinies, par exemple Légumes. Enfin, appuyez sur le bouton Lecture/Pause.

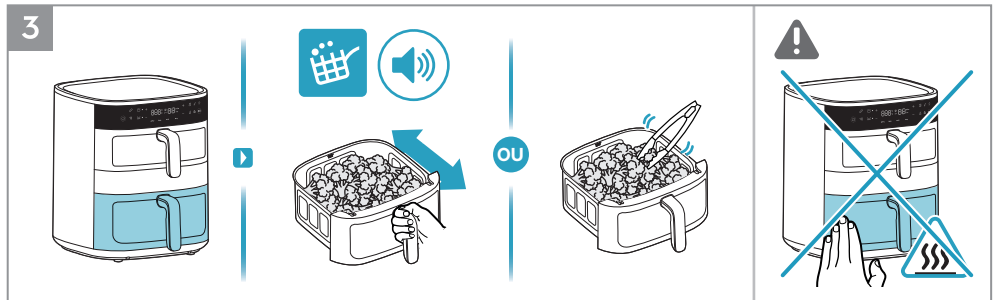

3. Lorsque l'icône " Shake Reminder " (Rappel de secouer) s'allume et émet un bip pendant la cuisson, utilisez des ustensiles résistants à la chaleur pour retourner les aliments une fois ou secouez délicatement les aliments dans à panier de friture.

⚠ **ATTENTION:** Ne secouez pas vigoureusement le panier de friture afin d'éviter les projections d'aliments et les brûlures.

⚠ **ATTENTION:** Faites attention aux surfaces chaudes lorsque l'appareil est en marche.

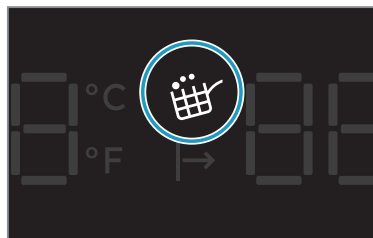

Rappel de secouer

La fonction " Shake Reminder " (Rappel de secouer) est activée pendant la fonction de Friture à l'air chaud et les recettes prédéfinies, telles que les légumes, le poisson, les cuisses de poulet et le bifteque.

Lorsque le moment est venu de secouer ou de retourner vos aliments, l'icône " Shake Reminder " (Rappel de secouer) s'allume et clignote pendant une minute, tandis qu'un bip retentit trois fois.

Le " Shake Reminder " (Rappel de secouer) n'est pas obligatoire; la cuisson se poursuivra donc normalement même si les aliments ne sont pas retournés ou secoués.



4. À la fin du temps de cuisson, l'appareil émettra un signal sonore. Retirez délicatement le panier et placez-le sur une surface résistante à la chaleur. Débranchez l'appareil après utilisation.

⚠ ATTENTION: De la vapeur chaude peut s'échapper du panier lorsqu'il est ouvert au milieu ou à la fin de la cuisson. Veillez à ce que votre visage, vos bras et vos mains soient éloignés de la vapeur lorsque vous ouvrez le panier.

Mode d'emploi - Panier supérieur + inférieur

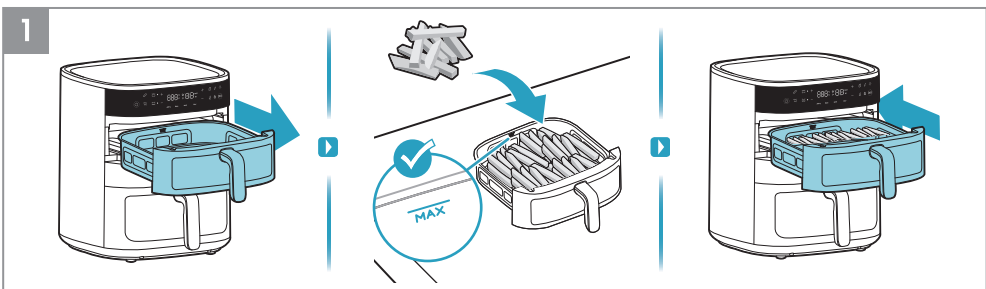

1. Tout d'abord, retirez le panier supérieur et placez les aliments dans le panier, par exemple des frites.

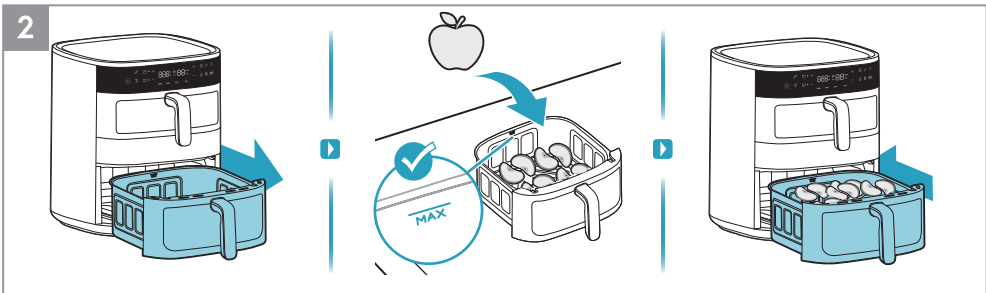

2. Ensuite, retirez le panier inférieur et placez les aliments dans le panier, par exemple des tranches de pomme.



3. Appuyez sur le bouton Activé/Désactivé. Sélectionnez d'abord le panier supérieur. Sélectionnez ensuite le mode de cuisson souhaité, par exemple la fonction de Friture à l'air chaud. Réglez le temps et la température selon vos préférences ou sélectionnez l'une des recettes prédéfinies, par exemple Légumes. Enfin, appuyez sur le bouton Lecture/Pause.

GB

BG

DE

ES

FR

GR

IT

PT

NL

CA

SE

FI

DK

NO

HU

AR



4. Ensuite, sélectionnez le panier inférieur. Sélectionnez ensuite le mode de cuisson souhaité, par exemple la fonction de Séchage. Réglez le temps et la température selon vos préférences. Enfin, appuyez sur le bouton Lecture/Pause.

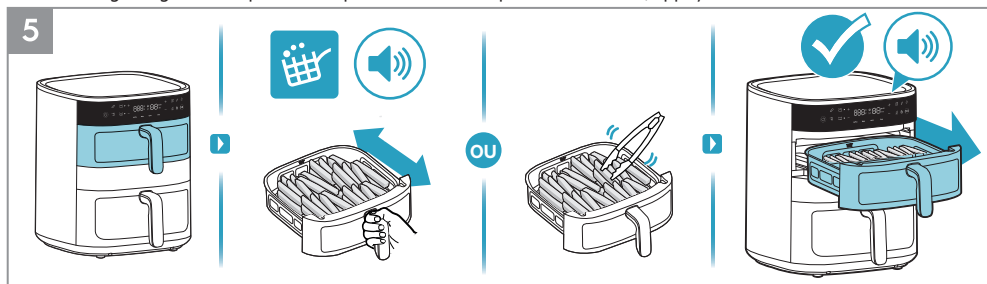

5. Lorsque l'icône "Shake Reminder" (Rappel de secouer) s'allume et émet un bip pendant la cuisson, utilisez des ustensiles résistants à la chaleur pour retourner les aliments une fois ou secouez délicatement les aliments dans le panier de friture. À la fin du temps de cuisson du panier supérieur, l'appareil émettra un signal sonore.

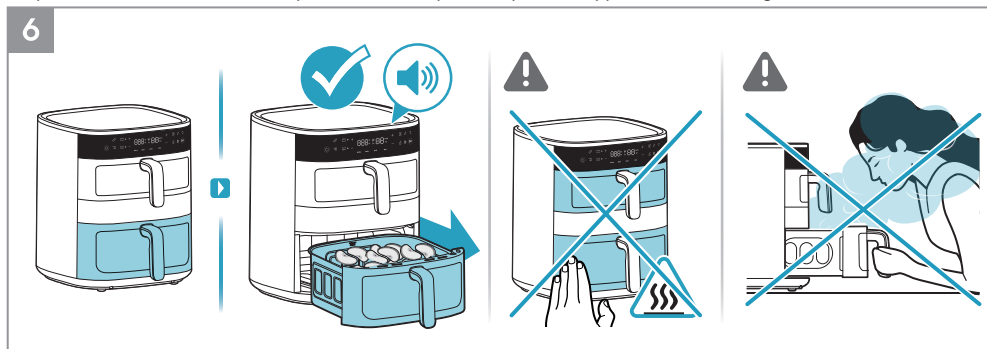

6. À la fin du temps de cuisson du panier inférieur, l'appareil émettra un signal sonore.

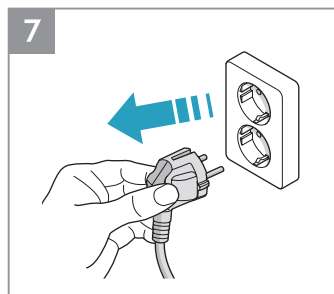

7. Débranchez l'appareil après utilisation.

Mode d'emploi - Fonction de liaison

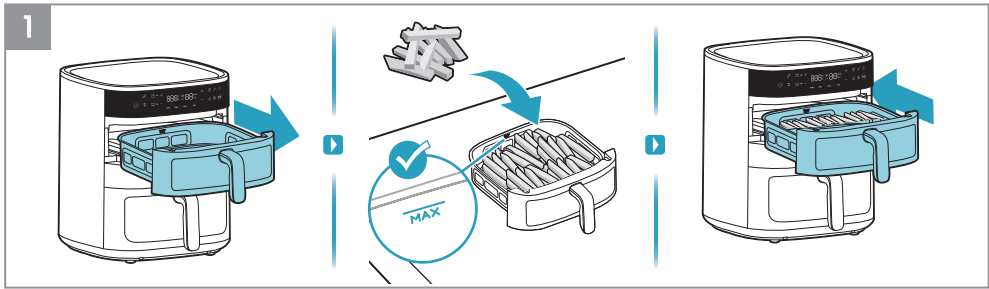

1. Tout d'abord, retirez le panier supérieur et placez les aliments dans le panier, par exemple des frites.

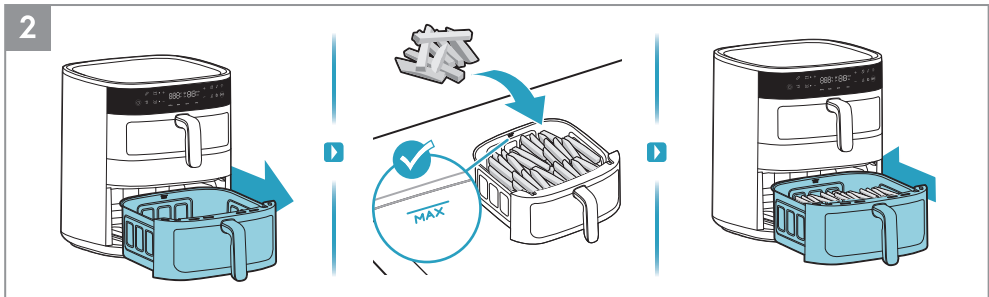

2. Ensuite, retirez le panier inférieur et placez les aliments dans le panier, par exemple des frites.



3. Appuyez sur le bouton Activé/Désactivé. Sélectionnez d'abord la fonction de liaison. Sélectionnez ensuite le mode de cuisson souhaité, par exemple la fonction de Friture à l'air chaud. Réglez le temps et la température selon vos préférences ou sélectionnez l'une des recettes prédéfinies. Enfin, appuyez sur le bouton Lecture/Pause.

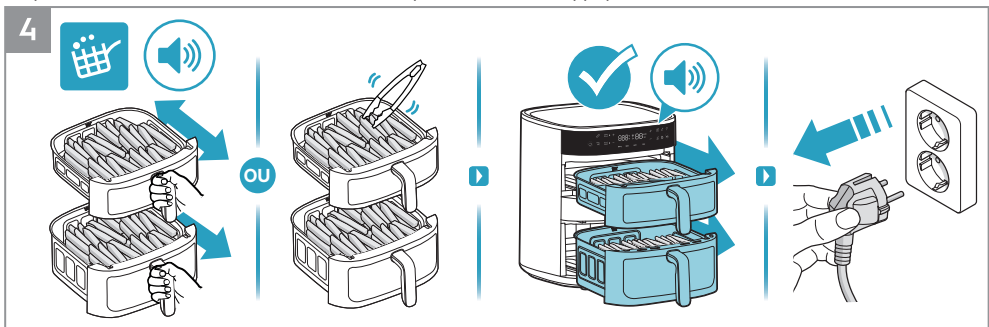

4. Lorsque l'icône "Shake Reminder" (Rappel de secouer) s'allume et émet un bip pendant la cuisson, utilisez des ustensiles résistants à la chaleur pour retourner les aliments une fois ou secouez délicatement les aliments dans à panier de friture. À la fin du temps de cuisson, l'appareil émettra un signal sonore. Débranchez l'appareil après utilisation.

GB

BG

DE

ES

FR

GR

IT

PT

NL

CA

SE

FI

DK

NO

HU

AR

Mode d'emploi - Fonction de fin de synchronisation

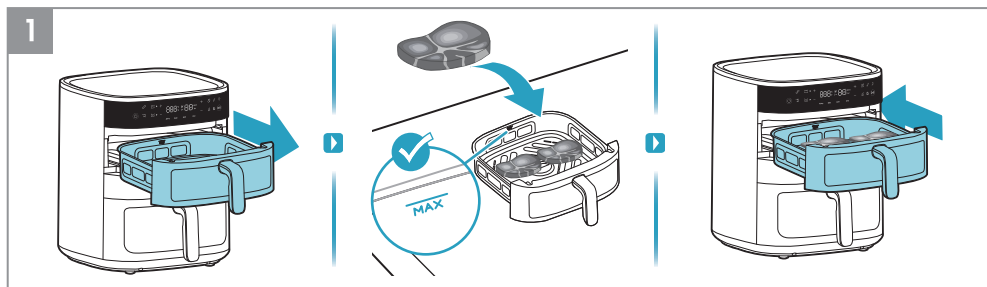

1. Tout d'abord, retirez le panier supérieur et placez les aliments dans le panier, par exemple du bifteque.

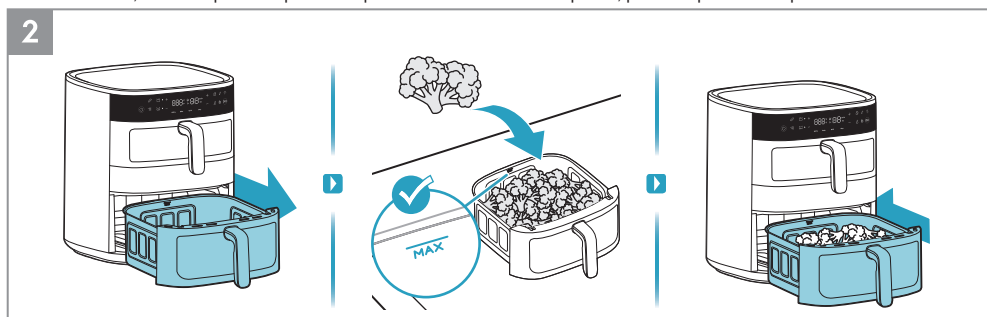

2. Ensuite, retirez le panier inférieur et placez les aliments dans le panier, par exemple du brocoli.

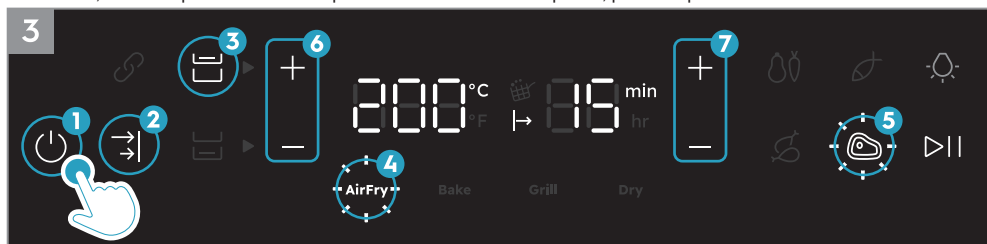

3. Appuyez sur le bouton Activé/Désactivé. Sélectionnez la fonction de fin de synchronisation. Sélectionnez d'abord le panier supérieur, puis choisissez le mode de cuisson souhaité, par exemple la fonction de Friture à l'air chaud. Réglez le temps et la température selon vos préférences ou sélectionnez l'une des recettes prédéfinies, par exemple Bifteque.



4. Sélectionnez ensuite le panier inférieur, puis choisissez le mode de cuisson souhaité, par exemple la fonction de Friture à l'air chaud. Réglez le temps et la température selon vos préférences ou sélectionnez l'une des recettes prédéfinies. Enfin, appuyez sur le bouton Lecture/Pause.

GB
BG
DE
ES
FR
GR
IT
PT
NL
CA
SE
FI
DK
NO
HU
AR

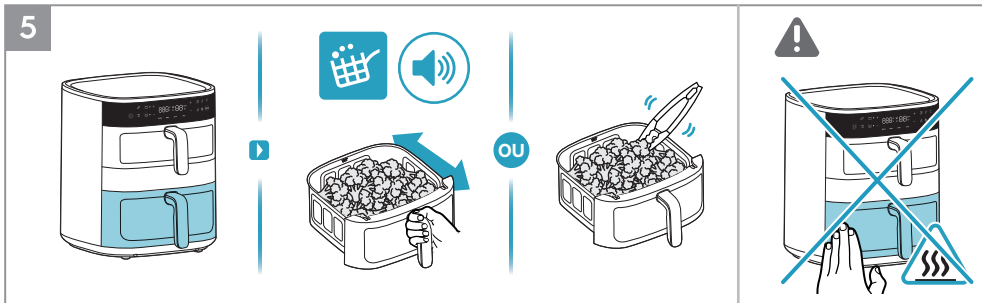

5. Tout d'abord, le panier inférieur avec un temps de cuisson plus long sera prioritaire pour la cuisson. Lorsque l'icône "Shake Reminder" (Rappel de secouer) s'allume et émet un bip pendant la cuisson, utilisez des ustensiles résistants à la chaleur pour retourner les aliments une fois ou secouez délicatement les aliments dans le panier de friture.

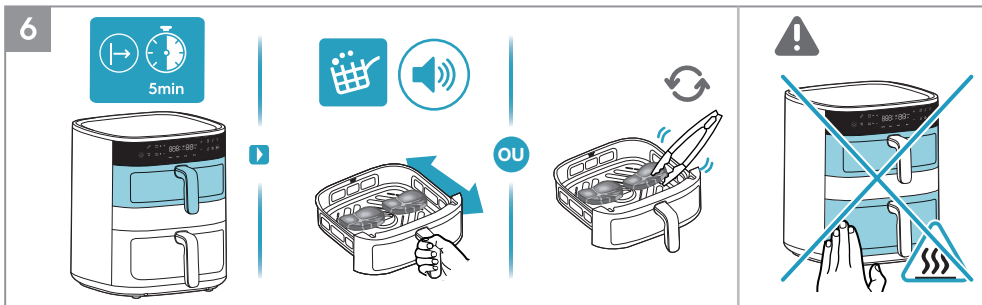

6. Ensuite, le panier supérieur avec un temps de cuisson plus court commencera la cuisson. Lorsque l'icône "Shake Reminder" (Rappel de secouer) s'allume et émet un bip pendant la cuisson, utilisez des ustensiles résistants à la chaleur pour retourner les aliments une fois ou secouez délicatement les aliments dans le panier de friture.

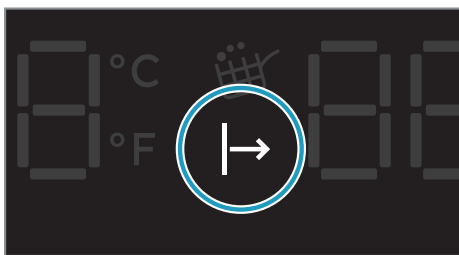

Voyant "En attente de cuisson"

Lorsque la fonction de fin de synchronisation est activée, le panier dont le temps de cuisson est plus court attendra d'abord que le panier dont le temps de cuisson est plus long ait cuit pendant un certain temps, afin que les deux paniers puissent terminer leur cuisson en même temps. Pendant cette période, le voyant "en attente de cuisson" restera allumé jusqu'au début de la cuisson.

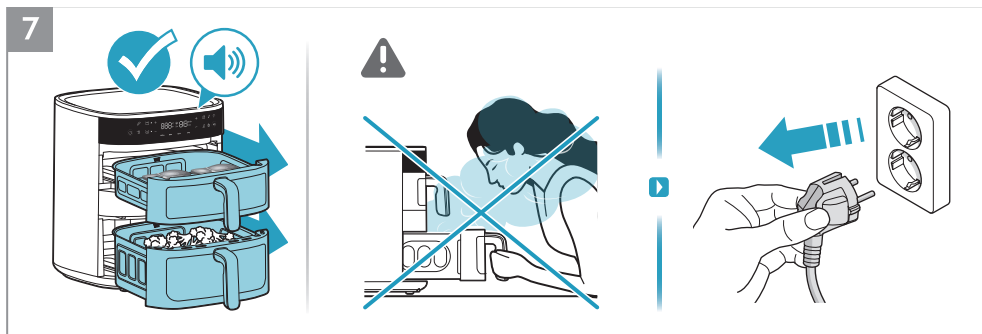

7. À la fin du temps de cuisson, l'appareil émettra un signal sonore. Débranchez l'appareil après utilisation.

Nettoyage

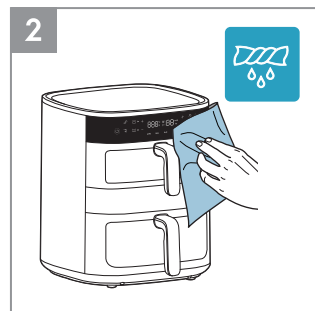
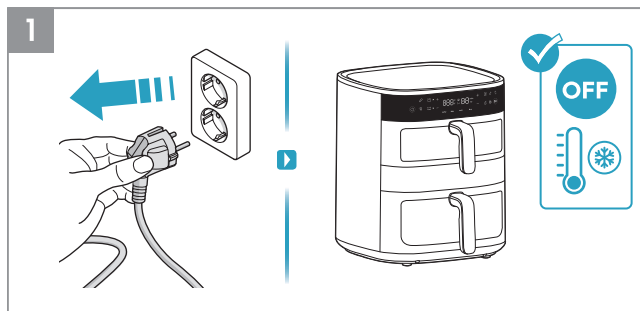

1. Débranchez toujours l'appareil et attendez qu'il refroidisse avant de le nettoyer.
2. Essayez l'extérieur de l'appareil avec un chiffon doux.

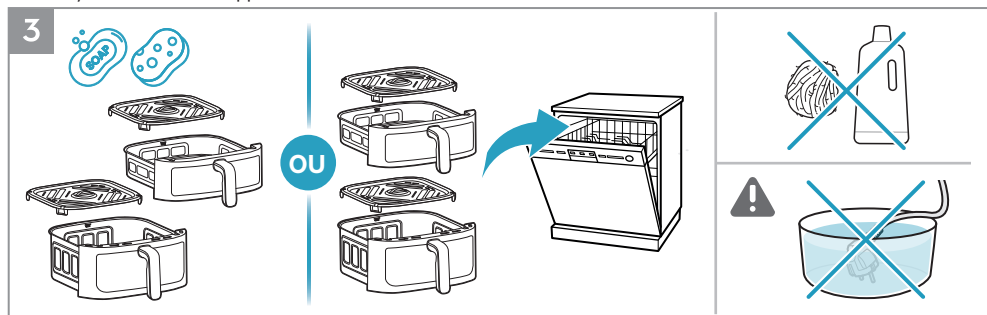

3. Nettoyez la poêle et la grille à l'eau chaude et au liquide vaisselle, ou mettez-les dans le lave-vaisselle.

REMARQUE: Évitez d'utiliser des produits nettoyants abrasifs ou des outils métalliques afin de protéger le revêtement antiadhésif.



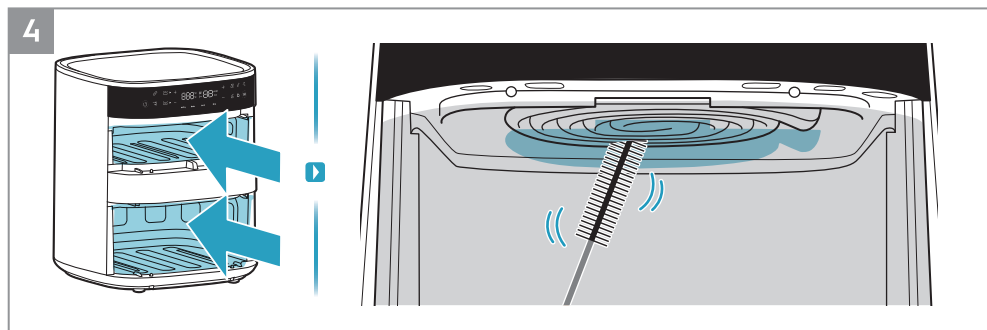























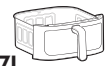











ATTENTION: Ne plongez jamais le produit, son cordon ou sa prise dans l'eau ou dans un autre liquide.







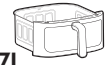







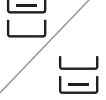











4. Nettoyez l'élément chauffant à l'aide d'une brosse de nettoyage.

REMARQUE: Assurez-vous que l'appareil est complètement refroidi avant de nettoyer l'élément chauffant.

Guide de cuisson

							
AirFry	7mm/10mm 	 4L	400g	180 °C	18min		
		 7L	400g	180 °C	18min		
AirFry		 4L	400g	170 °C	8min		
		 7L	400g	170 °C	10min		
AirFry		 4L	400g/2pièces	140 °C	15min		
		 7L	400g/2pièces	140 °C	15min		
AirFry		 4L	1000g/8pièces	180 °C	28min		
		 7L	1000g/8pièces	180 °C	28min		
AirFry		 4L	400g/2pièces	200 °C	10min		
		 7L	400g/2pièces	200 °C	10min		
AirFry		 4L	220g/6pouces	160 °C	12min		
		 7L	220g/6pouces	160 °C	14min		

- GB
- BG
- DE
- ES
- FR
- GR
- IT
- PT
- NL
- CA
- SE
- FI
- DK
- NO
- HU
- AR

							
AirFry		 7L	1200g	180 °C	55min		
AirFry		 7L	400g/9pièces	160 °C	20min		
Grill		 4L	180g/4pièces	180 °C	8min		
		 7L	180g/4pièces	180 °C	9min		
Dry		 4L	180g	80 °C	3h		
		 7L	180g	80 °C	3h		
Dry		 4L	200g	80 °C	3h		
		 7L	200g	80 °C	3h		

GB
BG
DE
ES
FR
GR
IT
PT
NL
CA
SE
FI
DK
NO
HU
AR

Que faire si...

Problème	Vérifier si...
Vous ne pouvez pas activer ou faire fonctionner l'appareil.	<ul style="list-style-type: none">• L'appareil est correctement connecté à une source d'alimentation électrique.• Les paniers sont dans la bonne position. Assurez-vous qu'ils sont complètement introduits dans l'appareil afin de permettre l'alimentation électrique.• Le temps de cuisson est défini.
Vous ne pouvez pas introduire le panier dans l'appareil.	<ul style="list-style-type: none">• Le panier est rempli à sa capacité maximale.• Le panier est correctement inséré. Il doit faire un bruit sec lorsque vous l'insérez dans l'appareil.• Un objet se trouve sous le panier, et il l'empêche de se fermer normalement.
De la fumée blanche s'échappe de l'appareil.	<ul style="list-style-type: none">• La nourriture que vous avez préparée est trop grasse.• Le panier, la grille et l'élément chauffant sont propres.
L'écran affiche E1.	<ul style="list-style-type: none">• Circuit ouvert du panier supérieur.
L'écran affiche E2.	<ul style="list-style-type: none">• Court-circuit du panier supérieur.
L'écran affiche E3.	<ul style="list-style-type: none">• Circuit ouvert du panier inférieur.
L'écran affiche E4.	<ul style="list-style-type: none">• Court-circuit du panier inférieur.
L'écran affiche E5.	<ul style="list-style-type: none">• Échec de communication de l'assemblage de circuits imprimés de contrôle.
L'écran affiche E6.	<ul style="list-style-type: none">• Échec de communication de l'assemblage de circuits imprimés d'alimentation.

* Si l'écran affiche des codes d'erreur, l'appareil doit être réparé par un centre de service.

Données techniques

Produit	Friteuse à l'air
Modèle	AAFD11B
Tension (V~)	220 V ~ 240 V
Puissance (W)	2700 W
Fréquence (Hz)	50 ~ 60 Hz
Capacité	4 L + 7 L

GB

BG

DE

ES

FR

GR

IT

PT

NL

CA

SE

FI

DK

NO

HU

AR



Εγχειρίδιο οδηγιών

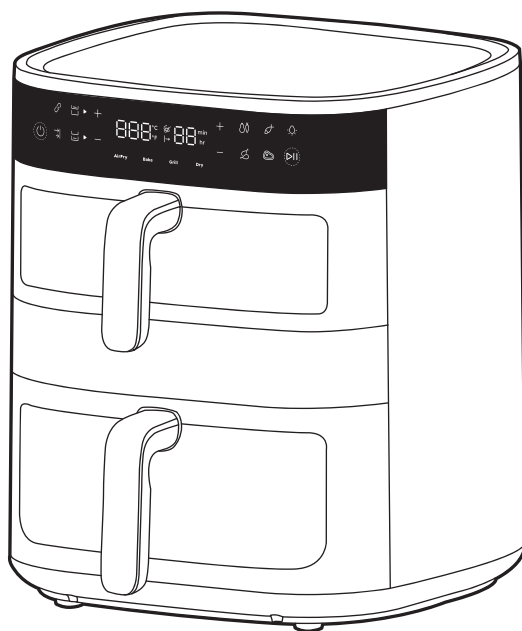

800 Διπλή φριτέζα αέρος

Γενική επισκόπηση

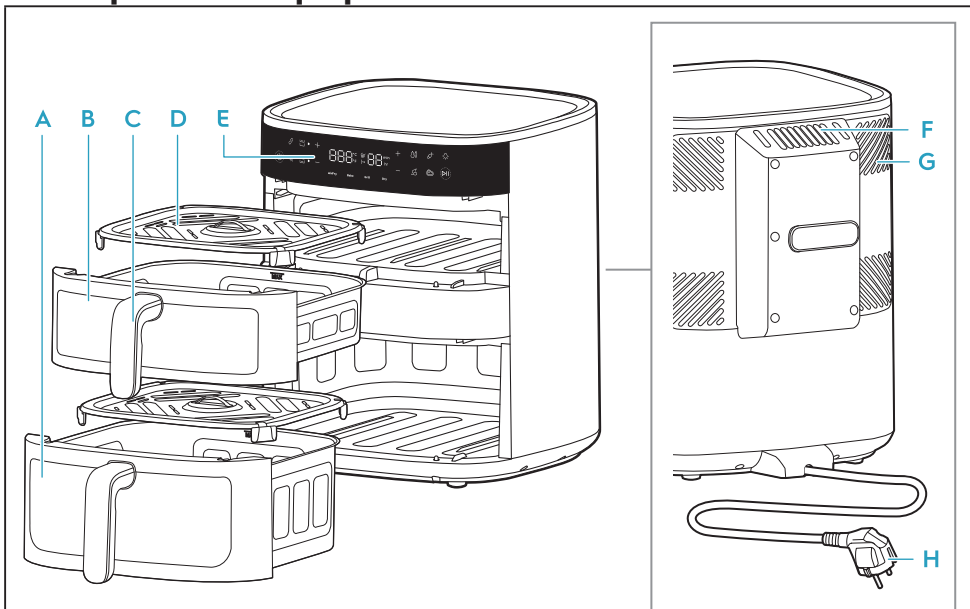

- A** Κάτω καλάθι (7 λίτρων) **C** Λαβή καλαθιού **E** Πίνακας ελέγχου **G** Σύστημα μείωσης θερμότητας
B Πάνω καλάθι (4 λίτρων) **D** Σχάρα **F** Έξοδος αέρα **H** Κύριο καλώδιο

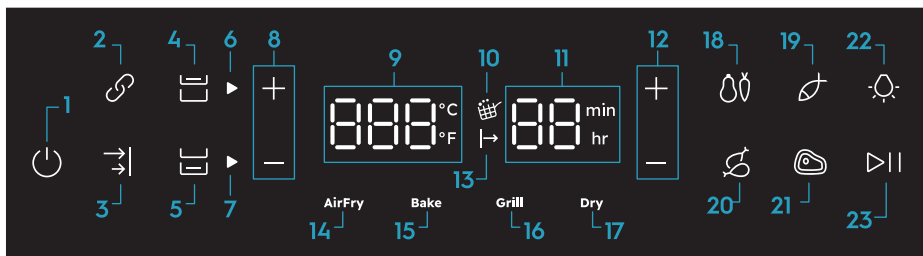

- | | | | |
|--|--|--|-------------------------------|
| 1. Ενεργοποίηση/
Απενεργοποίηση | 8. Έλεγχος
θερμοκρασίας | ώρες) | 17. Λειτουργία
αποξήρανσης |
| 2. Λειτουργία σύνδεσης | 9. Ένδειξη
θερμοκρασίας (40-
200°C) | 12. Έλεγχος χρόνου | 18. Λαχανικά |
| 3. Λειτουργία
συγχρονισμού
ολοκλήρωσης | 10. Υπενθύμιση
ανακίνησης | 13. Αναμονή για
μαγείρεμα | 19. Ψάρι |
| 4. Έλεγχος πάνω καλαθιού | 11. Ένδειξη χρόνου
(Ψήσιμο στον
αέρα: 1-99 λεπτά,
Αποξήρανση: 1-5 | 14. Λειτουργία
ψησίματος στον
αέρα | 20. Κοτόπουλο |
| 5. Έλεγχος κάτω καλαθιού | | 15. Λειτουργία
ψησίματος | 21. Μπριζόλα |
| 6. Ένδειξη πάνω καλαθιού | | 16. Λειτουργία γκριλ | 22. Έλεγχος φωτισμού |
| 7. Ένδειξη κάτω καλαθιού | | | 23. Αναπαραγωγή/
Παύση |

GB

BG

DE

ES

FR

GR

IT

PT

NL

CA

SE

FI

DK

NO

HU

AR

Πριν από την πρώτη χρήση

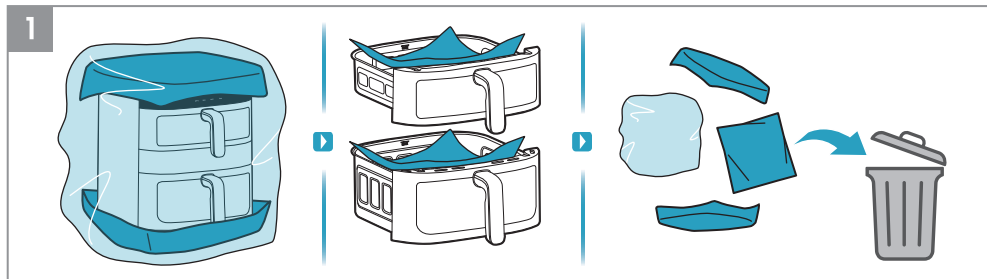

1. Αφαιρέστε όλα τα υλικά συσκευασίας και τα προστατευτικά υλικά.

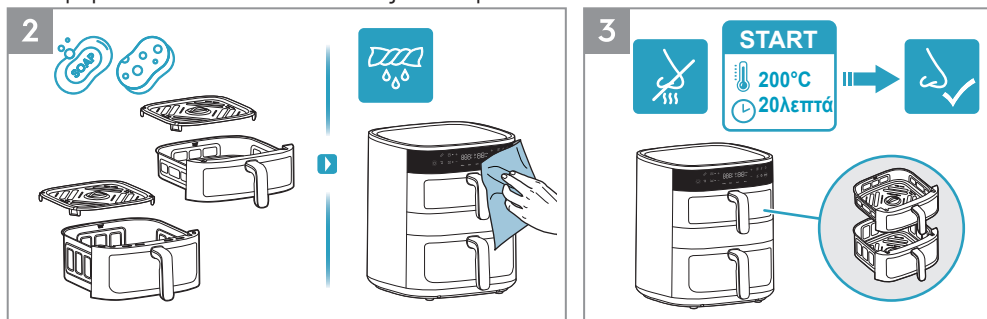

2. Καθαρίστε το ταψί και τη σχάρα με ζεστό νερό και σαπούνι για πιάτα. Σκουπίστε το εσωτερικό και το εξωτερικό της συσκευής με ένα μαλακό πανί.

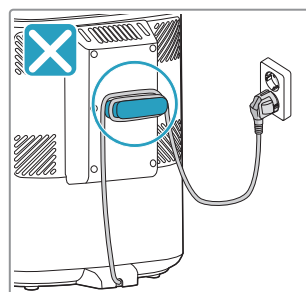
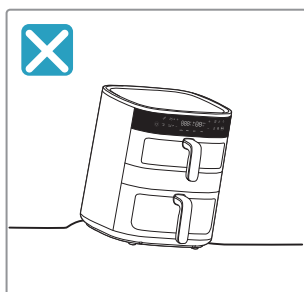
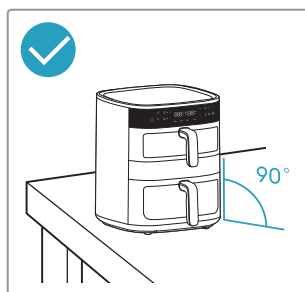
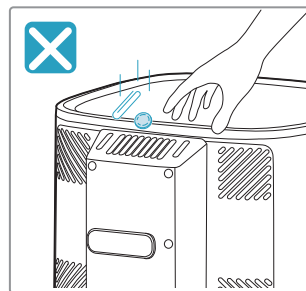
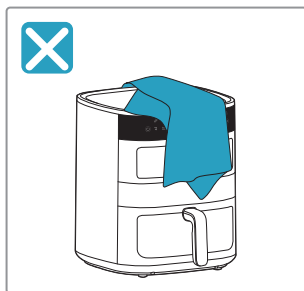
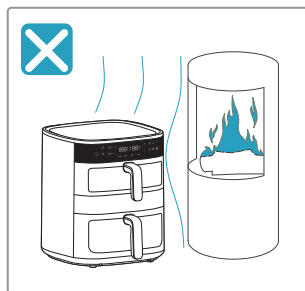

3. Είναι φυσιολογικό να υπάρχει οσμή από μια νέα συσκευή τις πρώτες φορές χρήσης. Λειτουργήστε την άδεια φριτέζα στους 200°C για 20 λεπτά πριν από την πρώτη χρήση, για να το αποφύγετε αυτό.

! Προφυλάξεις ασφαλείας





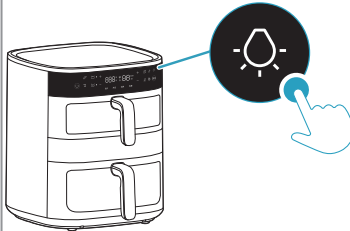
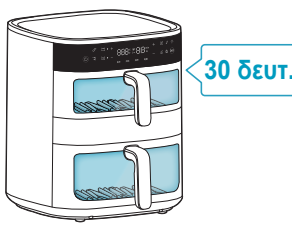

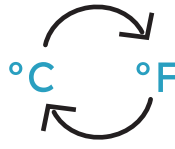





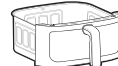



GB
BG
DE
ES
FR
GR
IT
PT
NL
CA
SE
FI
DK
NO
HU
AR

Έλεγχος φωτισμού και μετατροπή κλίμακας θερμοκρασίας





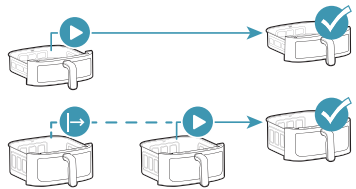





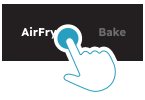



 <p>Έλεγχος φωτισμού</p>		
<p>°C/°F</p> <p>Μετατροπή κλίμακας θερμοκρασίας</p>		

Επιλογή καλαθιού

	 <p>4L</p>	 <p>7L</p>	
 <p>Πάνω καλάθι</p>			
 <p>Κάτω καλάθι</p>			
 <p>Λειτουργία σύνδεσης</p>			
 <p>Λειτουργία συγχρονισμού ολοκλήρωσης</p>			

- GB
- BG
- DE
- ES
- FR
- GR**
- IT
- PT
- NL
- CA
- SE
- FI
- DK
- NO
- HU
- AR

Προκαθορισμένες λειτουργίες

					
Air Fry	180°C	15λεπτά	60~200°C	1~99λεπτά	
	170°C	10λεπτά	60~200°C	1~99λεπτά	
	140°C	15λεπτά	60~200°C	1~99λεπτά	
	180°C	30λεπτά	60~200°C	1~99λεπτά	
	200°C	10λεπτά	60~200°C	1~99λεπτά	
Bake	170°C	15λεπτά	60~200°C	1~99λεπτά	
Grill	200°C	5λεπτά	60~200°C	1~99λεπτά	
Dry	80°C	5ώρες	40~80°C	1~5ώρες	

Πριν από το μαγείρεμα

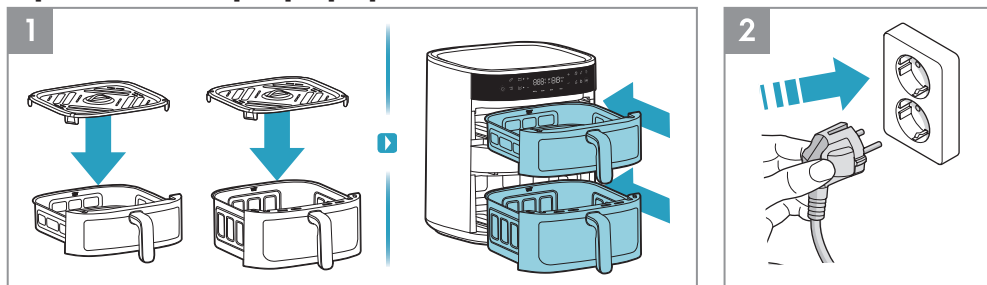

1. Πριν από κάθε μαγείρεμα, τοποθετήστε τη σχάρα μέσα στο καλάθι (το ανθεκτικό στη θερμότητα σιλικονούχο πέλημα στη σχάρα δεν χρειάζεται να αφαιρεθεί) και σπρώξτε τελείως το καλάθι μέσα στη συσκευή.
2. Εισαγάγετε το φις τροφοδοσίας στην ηλεκτρική πρίζα.

Τρόπος χρήσης - Μονό καλάθι

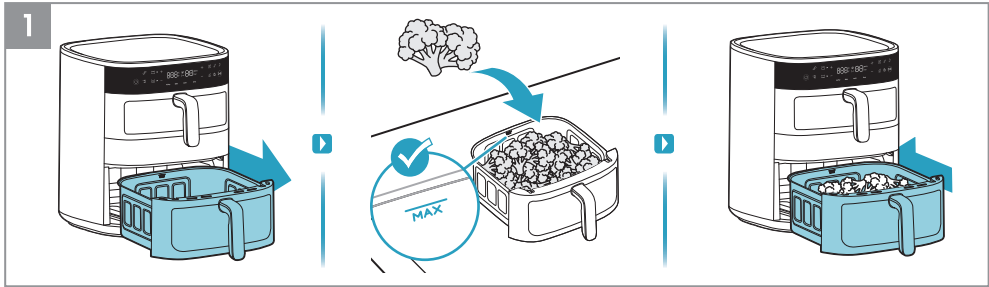

1. Τραβήξτε έξω ένα καλάθι, τοποθετήστε το σε μια σταθερή επιφάνεια και τοποθετήστε τα τρόφιμα στο καλάθι μέχρι το επίπεδο της ένδειξης πλήρωσης "MAX". Έπειτα στρώστε το καλάθι με τα τρόφιμα τελειώς μέσα στη συσκευή.

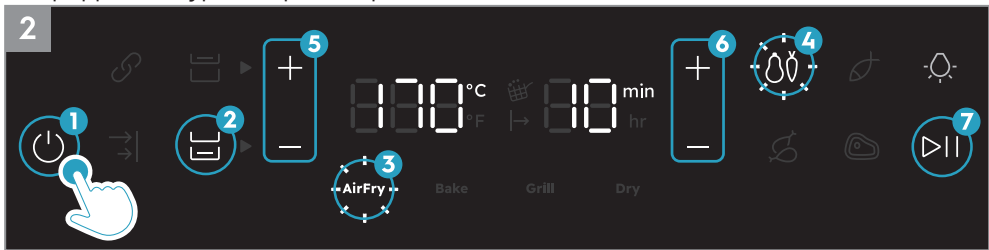

2. Πατήστε το κουμπί Ενεργοποίηση/Απενεργοποίηση. Πρώτα επιλέξτε το καλάθι με τα τρόφιμα. Έπειτα επιλέξτε την επιθυμητή μέθοδο μαγειρέματος, για παράδειγμα τη λειτουργία ψησίματος στον αέρα. Ρυθμίστε τον χρόνο και τη θερμοκρασία σύμφωνα με τις προτιμήσεις σας ή επιλέξτε μία από τις προκαθορισμένες συνταγές, για παράδειγμα Λαχανικά. Τέλος, πατήστε το κουμπί Αναπαραγωγή/Παύση.

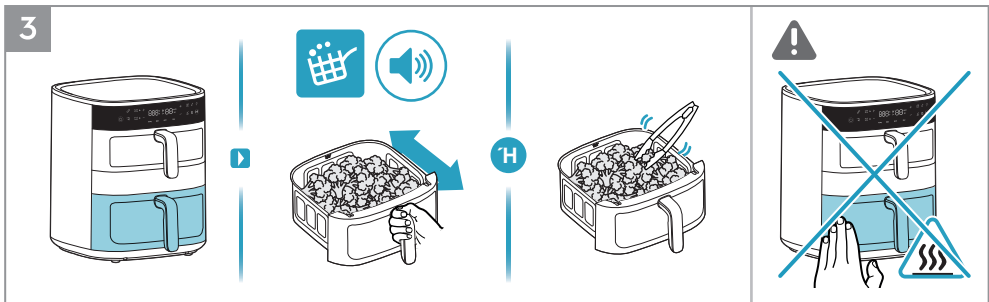

3. Όταν το εικονίδιο "Υπενθύμιση ανακίνησης" ανάβει και ακούγεται ένας ήχος κατά τη διαδικασία του μαγειρέματος, χρησιμοποιήστε εργαλεία ανθεκτικά στη θερμότητα για να γυρίσετε τα τρόφιμα μία φορά ή ανακινήστε προσεκτικά τα τρόφιμα ελαφρώς στο καλάθι ψησίματος.

⚠ **ΠΡΟΣΟΧΗ:** Μην ανακινείτε το καλάθι ψησίματος δυνατά, για να μη πιτσιλιστούν τρόφιμα και προκληθούν εγκαύματα.

⚠ **ΠΡΟΣΟΧΗ:** Να είστε προσεκτικοί με τις καυτές επιφάνειες όταν χρησιμοποιείται η συσκευή.

Υπενθύμιση ανακίνησης

Η "Υπενθύμιση ανακίνησης" ενεργοποιείται κατά τη λειτουργία ψησίματος στον αέρα και τις προκαθορισμένες συνταγές, όπως λαχανικά, ψάρι, μπουτία κοτόπουλου και μπριζόλα.

Όταν έρθει η στιγμή να ανακινήσετε ή να γυρίσετε τα τρόφιμά σας, το εικονίδιο "Υπενθύμιση ανακίνησης" θα ανάψει και θα αναβοσβήνει για ένα λεπτό, ενώ ένας χαρακτηριστικός ήχος θα επαναληφθεί τρεις φορές. Η "Υπενθύμιση ανακίνησης" δεν είναι υποχρεωτική, επομένως το μαγείρεμα θα συνεχιστεί κανονικά, ακόμη και αν δεν ανακινήσετε ή γυρίσετε το φαγητό.

GB

BG

DE

ES

FR

GR

IT

PT

NL

CA

SE

FI

DK

NO

HU

AR



4. Στο τέλος του χρόνου μαγειρέματος, θα ακουστεί ένας χαρακτηριστικός ήχος από τη συσκευή. Αφαιρέστε προσεκτικά το καλάθι και τοποθετήστε το σε μια επιφάνεια ανθεκτική στη θερμότητα. Βγάλτε το φινις της συσκευής από την πρίζα μετά τη χρήση.

⚠ **ΠΡΟΣΟΧΗ:** Μπορεί να βγει καυτός ατμός από το καλάθι όταν ανοίγετε τη συσκευή στη μέση ή στο τέλος του μαγειρέματος. Βεβαιωθείτε ότι το πρόσωπο, τα μπράτσα και τα χέρια σας είναι μακριά από τον ατμό όταν την ανοίγετε.

Τρόπος χρήσης - Πάνω + κάτω καλάθι

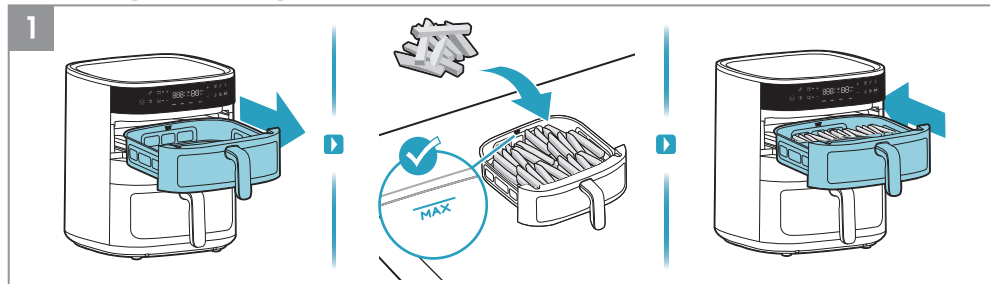

1. Πρώτα, τραβήξτε έξω το πάνω καλάθι και τοποθετήστε τα τρόφιμα στο καλάθι, για παράδειγμα τηγανιτές πατάτες.

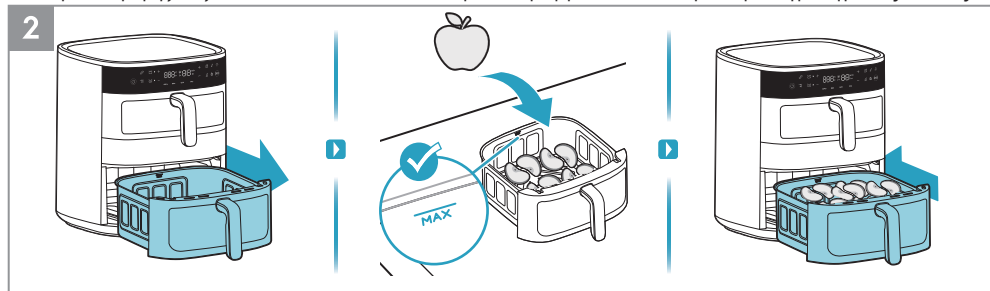

2. Έπειτα, τραβήξτε έξω το κάτω καλάθι και τοποθετήστε τα τρόφιμα στο καλάθι, για παράδειγμα φέτες μήλου.



3. Πατήστε το κουμπί Ενεργοποίηση/Απενεργοποίηση. Πρώτα επιλέξτε το πάνω καλάθι. Έπειτα επιλέξτε την επιθυμητή μέθοδο μαγειρέματος, για παράδειγμα τη λειτουργία ψησίματος στον αέρα. Ρυθμίστε τον χρόνο και τη θερμοκρασία σύμφωνα με τις προτιμήσεις σας ή επιλέξτε μία από τις προκαθορισμένες συνταγές, για παράδειγμα Λαχανικά. Τέλος, πατήστε το κουμπί Αναπαραγωγή/Παύση.



4. Στη συνέχεια, επιλέξτε το κάτω καλάθι. Έπειτα επιλέξτε την επιθυμητή μέθοδο μαγειρέματος, για παράδειγμα λειτουργία αποξήρανσης. Ρυθμίστε τον χρόνο και τη θερμοκρασία σύμφωνα με τις προτιμήσεις σας. Τέλος, πατήστε το κουμπί Αναπαραγωγή/Παύση.

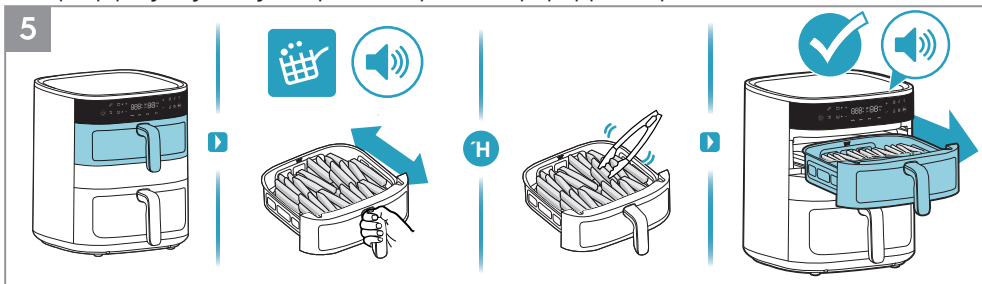

5. Όταν το εικονίδιο “Υπενθύμηση ανακίνησης” ανάβει και ακούγεται ένας ήχος κατά τη διαδικασία του μαγειρέματος, χρησιμοποιήστε εργαλεία ανθεκτικά στη θερμότητα για να γυρίσετε τα τρόφιμα μία φορά ή ανακινήστε προσεκτικά τα τρόφιμα ελαφρώς στο καλάθι ψησίματος. Στο τέλος του χρόνου μαγειρέματος του πάνω καλάθιού, θα ακουστεί ένας χαρακτηριστικός ήχος από τη συσκευή.

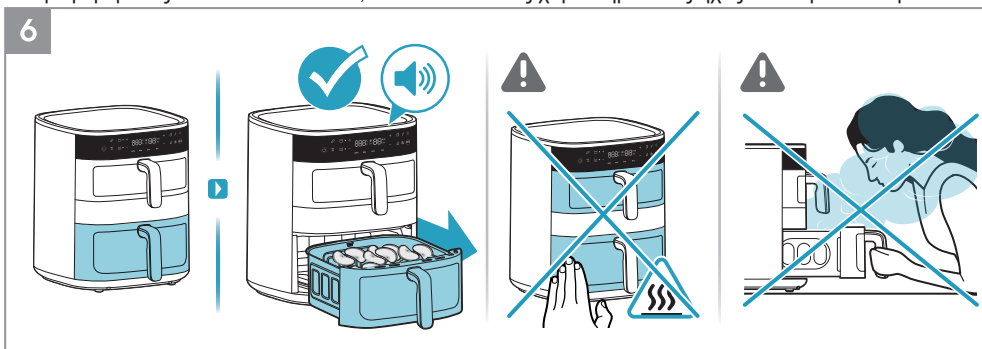

6. Στο τέλος του χρόνου μαγειρέματος του κάτω καλάθιού, θα ακουστεί ένας χαρακτηριστικός ήχος από τη συσκευή.

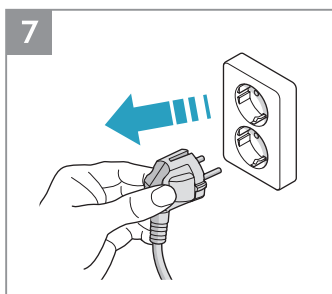

7. Βγάλτε το φις της συσκευής από την πρίζα μετά τη χρήση.

GB
BG
DE
ES
FR
GR
IT
PT
NL
CA
SE
FI
DK
NO
HU
AR

Τρόπος χρήσης - Λειτουργία σύνδεσης

1

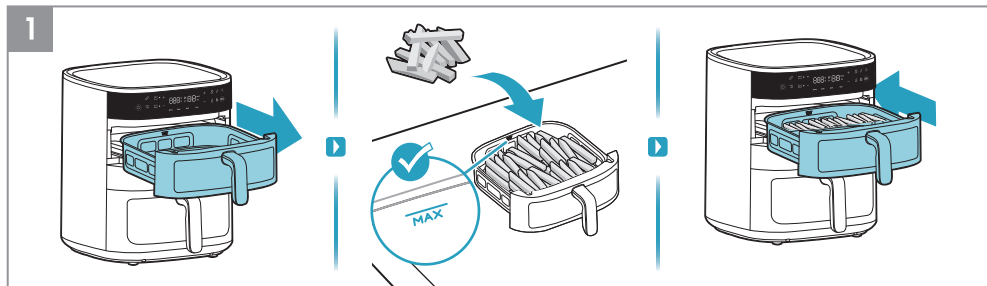

1. Πρώτα, τραβήξτε έξω το πάνω καλάθι και τοποθετήστε τα τρόφιμα στο καλάθι, για παράδειγμα τηγανιτές πατάτες.

2

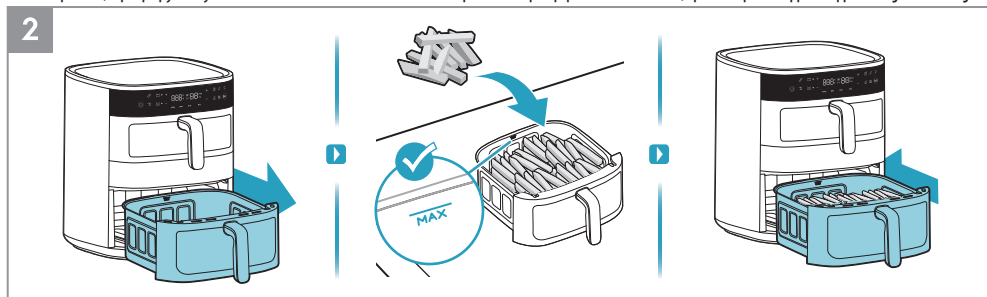

2. Έπειτα, τραβήξτε έξω το κάτω καλάθι και τοποθετήστε τα τρόφιμα στο καλάθι, για παράδειγμα τηγανιτές πατάτες.

3



3. Πατήστε το κουμπί Ενεργοποίησης/Απενεργοποίησης. Πρώτα επιλέξτε τη λειτουργία σύνδεσης. Έπειτα επιλέξτε την επιθυμητή μέθοδο μαγειρέματος, για παράδειγμα τη λειτουργία ψησίματος στον αέρα. Ρυθμίστε τον χρόνο και τη θερμοκρασία σύμφωνα με τις προτιμήσεις σας ή επιλέξτε μία από τις προκαθορισμένες συνταγές. Τέλος, πατήστε το κουμπί Αναπαραγωγή/Παύση.

4

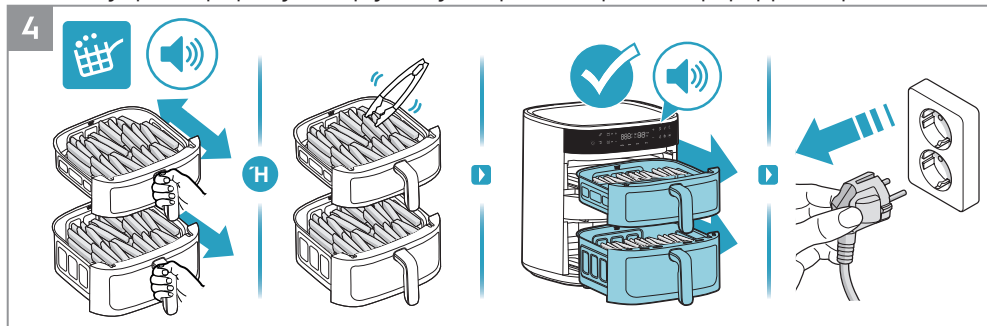

4. Όταν το εικονίδιο "Υπευθύνιση ανακίνησης" ανάβει και ακούγεται ένας ήχος κατά τη διαδικασία του μαγειρέματος, χρησιμοποιήστε εργαλεία ανθεκτικά στη θερμότητα για να γυρίσετε τα τρόφιμα μία φορά ή ανακινήστε προσεκτικά τα τρόφιμα ελαφρώς στο καλάθι ψησίματος. Στο τέλος του χρόνου μαγειρέματος, θα ακουστεί ένας χαρακτηριστικός ήχος από τη συσκευή. Βγάλτε το φις της συσκευής από την πρίζα μετά τη χρήση.

Τρόπος χρήσης - Λειτουργία συγχρονισμού ολοκλήρωσης

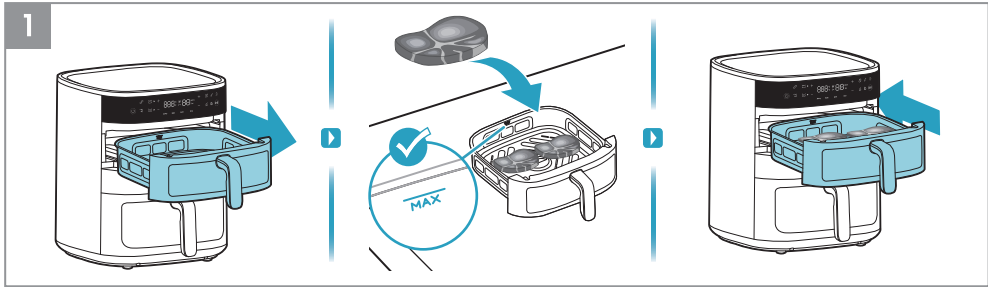

1. Πρώτα, τραβήξτε έξω το πάνω καλάθι και τοποθετήστε τα τρόφιμα στο καλάθι, για παράδειγμα μπριζόλα.

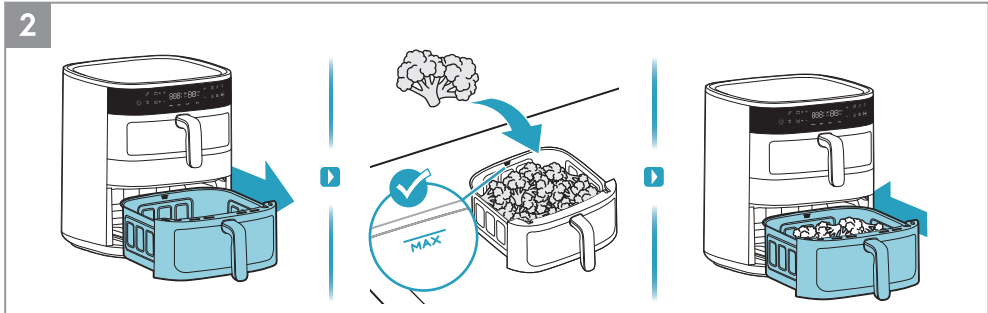

2. Έπειτα, τραβήξτε έξω το κάτω καλάθι και τοποθετήστε τα τρόφιμα στο καλάθι, για παράδειγμα μπρόκολο.



3. Πατήστε το κουμπί Ενεργοποίηση/Απενεργοποίηση. Επιλέξτε τη λειτουργία συγχρονισμού ολοκλήρωσης. Πρώτα επιλέξτε το πάνω καλάθι, έπειτα επιλέξτε την επιθυμητή μέθοδο μαγειρέματος, για παράδειγμα τη λειτουργία ψησίματος στον αέρα. Ρυθμίστε τον χρόνο και τη θερμοκρασία σύμφωνα με τις προτιμήσεις σας ή επιλέξτε μία από τις προκαθορισμένες συνταγές, για παράδειγμα Μπριζόλα.

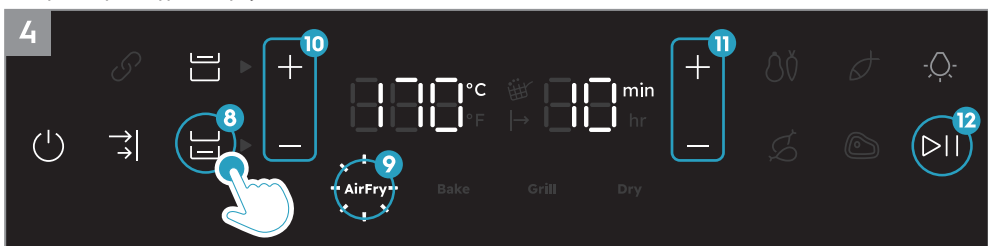

4. Και έπειτα επιλέξτε το κάτω καλάθι, επιλέξτε την επιθυμητή μέθοδο μαγειρέματος, για παράδειγμα τη λειτουργία ψησίματος στον αέρα. Ρυθμίστε τον χρόνο και τη θερμοκρασία σύμφωνα με τις προτιμήσεις σας ή επιλέξτε μία από τις προκαθορισμένες συνταγές. Τέλος, πατήστε το κουμπί Αναπαραγωγή/Παύση.

GB

BG

DE

ES

FR

GR

IT

PT

NL

CA

SE

FI

DK

NO

HU

AR

5

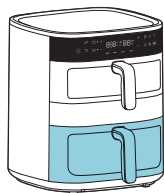

H



5. Πρώτα, το κάτω καλάθι με τον μεγαλύτερο ρυθμισμένο χρόνο θα έχει προτεραιότητα στο μαγείρεμα. Όταν το εικονίδιο “Υπενθύμιση ανακίνησης” ανάβει και ακούγεται ένας ήχος κατά τη διαδικασία του μαγειρέματος, χρησιμοποιήστε εργαλεία ανθεκτικά στη θερμότητα για να γυρίσετε τα τρόφιμα μία φορά ή ανακινήστε προσεκτικά τα τρόφιμα ελαφρώς στο καλάθι ψησίματος.

6

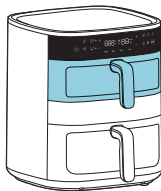

H

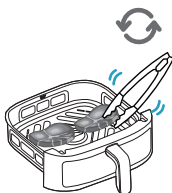

6. Έπειτα, θα αρχίσει το μαγείρεμα στο πάνω καλάθι με τον μικρότερο ρυθμισμένο χρόνο. Όταν το εικονίδιο “Υπενθύμιση ανακίνησης” ανάβει και ακούγεται ένας ήχος κατά τη διαδικασία του μαγειρέματος, χρησιμοποιήστε εργαλεία ανθεκτικά στη θερμότητα για να γυρίσετε τα τρόφιμα μία φορά ή ανακινήστε προσεκτικά τα τρόφιμα ελαφρώς στο καλάθι ψησίματος.

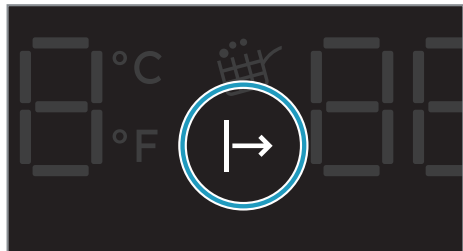

Αναμονή για ένδειξη μαγειρέματος

Όταν η “Λειτουργία συγχρονισμού ολοκλήρωσης” είναι ενεργοποιημένη, το μαγείρεμα στο καλάθι με τον μικρότερο χρόνο μαγειρέματος θα είναι σε αναμονή μέχρι το καλάθι με τον μεγαλύτερο χρόνο μαγειρέματος να λειτουργεί για λίγη ώρα, ώστε και τα δύο καλάθια να ολοκληρώσουν το μαγείρεμα ταυτόχρονα. Κατά τη διάρκεια αυτής της περιόδου, η ένδειξη “αναμονή για μαγείρεμα” θα ανάβει μέχρι να ξεκινήσει το μαγείρεμα.

7

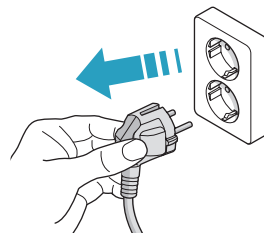
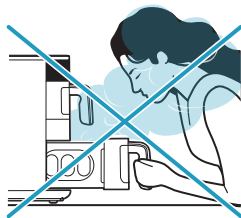
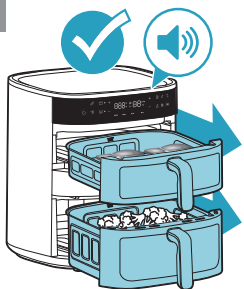

7. Στο τέλος του χρόνου μαγειρέματος, θα ακουστεί ένας χαρακτηριστικός ήχος από τη συσκευή. Βγάλτε το φις της συσκευής από την πρίζα μετά τη χρήση.

GB

BG

DE

ES

FR

GR

IT

PT

NL

CA

SE

FI

DK

NO

HU

AR

Καθαρισμός

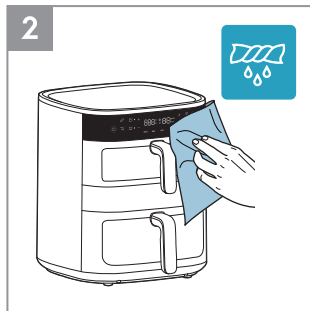
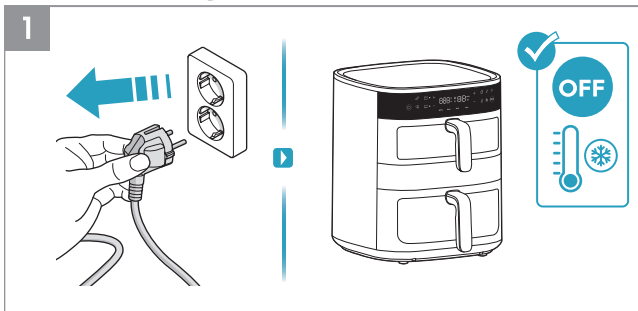

1. Αποσυνδέετε πάντα τη συσκευή από την πρίζα και περιμένετε μέχρι να κρυώσει πριν την καθαρίσετε.
2. Σκουπίστε το εξωτερικό της συσκευής με ένα μαλακό πανί.

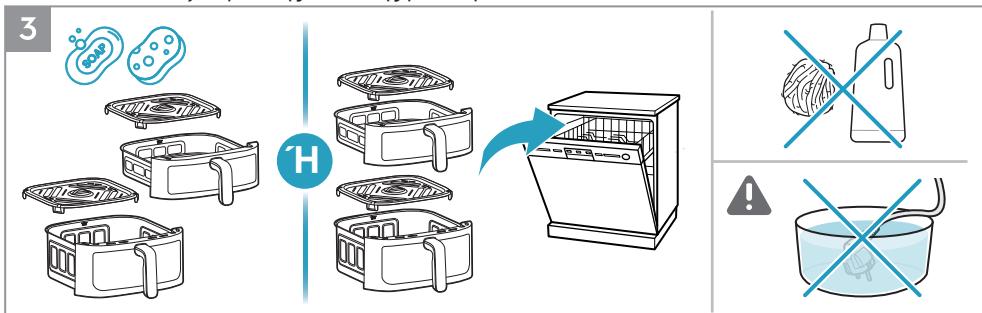

3. Καθαρίστε τον δίσκο και τη σχάρα με ζεστό νερό και σαπούνι για πιάτα ή τοποθετήστε τα στο πλυντήριο πιάτων.

ΔΣΗΜΕΙΩΣΗ: Αποφύγετε τη χρήση διαβρωτικών προϊόντων καθαρισμού ή μεταλλικών εργαλείων, για την προστασία της αντικολλητικής επίστρωσης.

ΠΡΟΣΟΧΗ: Μη βυθίζετε το προϊόν, το καλώδιο ή το φισ σε νερό ή σε άλλα υγρά.

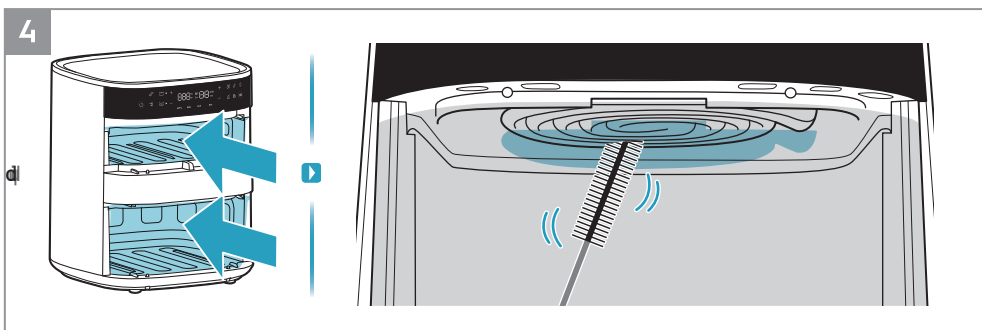

4. Καθαρίζετε το θερμαντικό στοιχείο με βούρτσα καθαρισμού.

ΣΗΜΕΙΩΣΗ: Βεβαιωθείτε ότι η συσκευή έχει κρυώσει τελείως πριν καθαρίσετε το θερμαντικό στοιχείο.

GB

BG

DE

ES

FR

GR

IT

PT

NL

CA

SE

FI



















DK

NO

HU













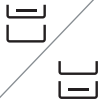





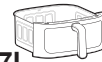

AR

Οδηγός μαγειρέματος

Recipe							
AirFry	7mm/10mm 	4L	400g	180°C	18λεπτά		
		7L	400g	180°C	18λεπτά		
AirFry		4L	400g	170°C	8λεπτά		
		7L	400g	170°C	10λεπτά		
AirFry		4L	400g/2τεμ.	140°C	15λεπτά		
		7L	400g/2τεμ.	140°C	15λεπτά		
AirFry		4L	1000g/8τεμ.	180°C	28λεπτά		
		7L	1000g/8τεμ.	180°C	28λεπτά		
AirFry		4L	400g/2τεμ.	200°C	10λεπτά		
		7L	400g/2τεμ.	200°C	10λεπτά		
AirFry		4L	220g/6ίντσες	160°C	12λεπτά		
		7L	220g/6ίντσες	160°C	14λεπτά		

GB
BG
DE
ES
FR
GR

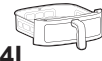
IT
PT
NL
CA
SE
FI
DK
NO
HU
AR

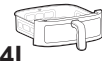
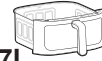
							
AirFry		 7L	1200g	180°C	55λεπτά		
AirFry		 7L	400g/9τεμ.	160°C	20λεπτά		
Grill		 4L	180g/4τεμ.	180°C	8λεπτά		
		 7L	180g/4τεμ.	180°C	9λεπτά		
Dry		 4L	180g	80°C	3ώρες		
		 7L	180g	80°C	3ώρες		
Dry		 4L	200g	80°C	3ώρες		
		 7L	200g	80°C	3ώρες		

GB

BG

DE

ES

FR

GR

IT

PT

NL

CA

SE

FI

DK

NO

HU

AR

Τι να κάνετε αν...

Πρόβλημα	Ελέγξτε αν...
Δεν μπορείτε να ενεργοποιήσετε ή να λειτουργήσετε τη συσκευή.	<ul style="list-style-type: none"> • Η συσκευή έχει συνδεθεί σωστά στην παροχή ρεύματος. • Τα καλάθια είναι στη σωστή θέση. Βεβαιωθείτε ότι τα έχετε σπρώξει τελείως μέσα στη συσκευή για να ενεργοποιηθεί η τροφοδοσία. • Ο χρόνος μαγειρέματος έχει ρυθμιστεί.
Δεν μπορείτε να εισαγάγετε το καλάθι μέσα στη συσκευή.	<ul style="list-style-type: none"> • Το καλάθι έχει γεμίσει πάνω από τη μέγιστη χωρητικότητα. • Το καλάθι έχει τοποθετηθεί σωστά. Πρέπει να κουμπώσει με τον χαρακτηριστικό ήχο όταν το τοποθετείτε μέσα στη μονάδα. • Υπάρχει ένα αντικείμενο κάτω από το καλάθι που σας εμποδίζει να κλείσετε τη συσκευή σωστά.
Βγαίνει λευκός καπνός από τη συσκευή.	<ul style="list-style-type: none"> • Το φαγητό που ετοιμάζετε είναι πολύ λιπαρό. • Το καλάθι, η σχάρα και το θερμαντικό στοιχείο είναι καθαρά.
Στην οθόνη εμφανίζεται η ένδειξη E1	•Ανοιχτό κύκλωμα πάνω καλαθιού.
Στην οθόνη εμφανίζεται η ένδειξη E2	•Βραχυκύκλωμα πάνω καλαθιού.
Στην οθόνη εμφανίζεται η ένδειξη E3	•Ανοιχτό κύκλωμα κάτω καλαθιού.
Στην οθόνη εμφανίζεται η ένδειξη E4	•Βραχυκύκλωμα κάτω καλαθιού.
Στην οθόνη εμφανίζεται η ένδειξη E5	•Σφάλμα επικοινωνίας ελέγχου PCBA.
Στην οθόνη εμφανίζεται η ένδειξη E6	•Σφάλμα επικοινωνίας ισχύος PCBA.

* Σε περίπτωση που στην οθόνη εμφανίζονται κωδικοί σφάλματος, η συσκευή πρέπει να επισκευαστεί από ένα κέντρο σέρβις.

Τεχνικά στοιχεία

Προϊόν	Φριτέζα αέρος
Μοντέλο	AAFD11B
Τάση (V~)	220 V ~ 240 V
Ισχύς (W)	2700 W
Συχνότητα (Hz)	50 ~ 60 Hz
Χωρητικότητα	4 λίτρα + 7 λίτρα



Manuale di istruzioni

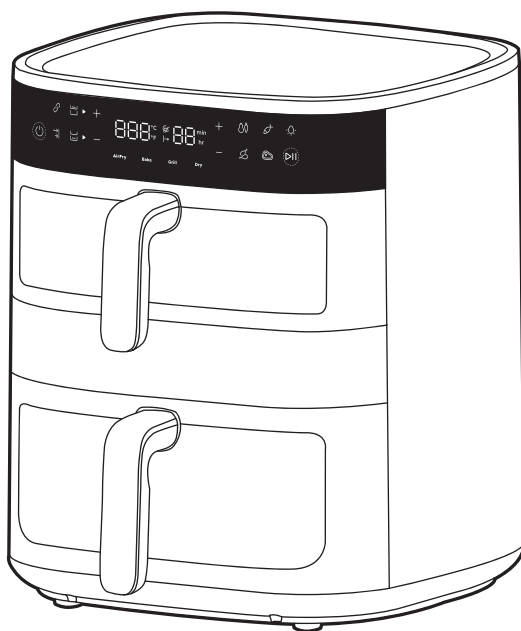

Friggitrice ad aria doppia 800

Panoramica generale

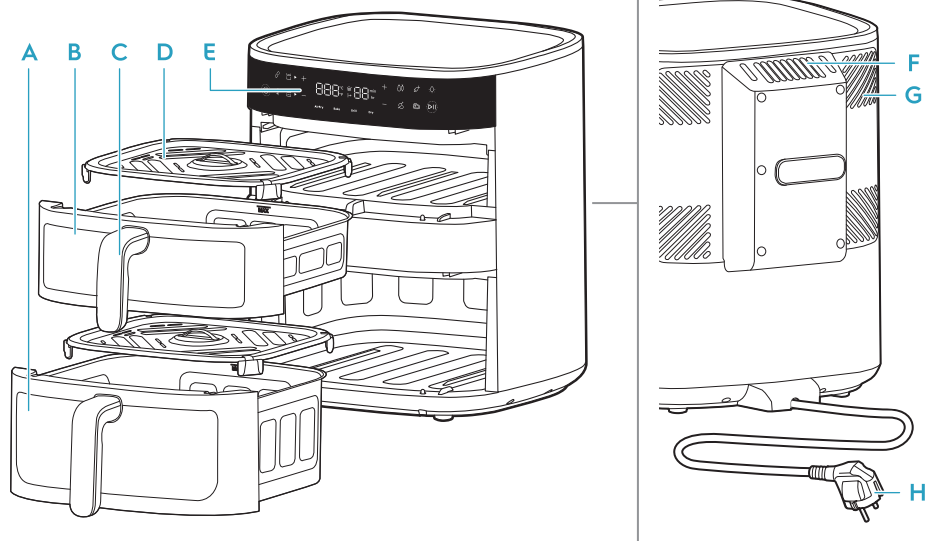

- | | | | |
|----------------------------------|--------------------------------|--------------------------------|------------------------------------|
| A Cestello inferiore (7L) | C Maniglia del cestello | E Pannello di controllo | G Sistema di raffreddamento |
| B Cestello superiore (4L) | D Griglia | F Presa d'aria | H Cavo di alimentazione |

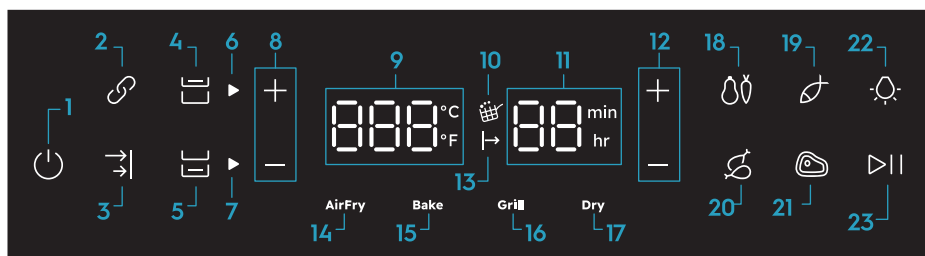

- | | | |
|--------------------------------------|---|---------------------------|
| 1. On/Off | 9. Indicatore della temperatura (40-200 °C) | 16. Funzione grill |
| 2. Funzione Link | 10. Promemoria agitazione | 17. Funzione essiccazione |
| 3. Funzione di fine sincronizzazione | 11. Indicatore del tempo (AirFry: 1-99 min, Disidrata: 1- 5h) | 18. Verdure |
| 4. Controllo cestello superiore | 12. Controllo del tempo | 19. Pesce |
| 5. Controllo cestello inferiore | 13. In attesa di cottura | 20. Pollo |
| 6. Indicatore cestello superiore | 14. Funzione AirFry | 21. Bistecca |
| 7. Indicatore cestello inferiore | 15. Funzione cottura al forno | 22. Controllo luce |
| 8. Controllo della temperatura | | 23. Riproduzione/Pausa |

Prima del primo utilizzo

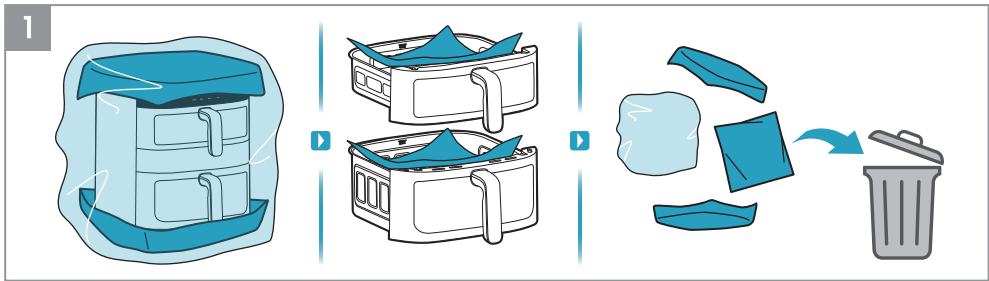

1. Rimuovere tutto l'imballaggio e il materiale protettivo.

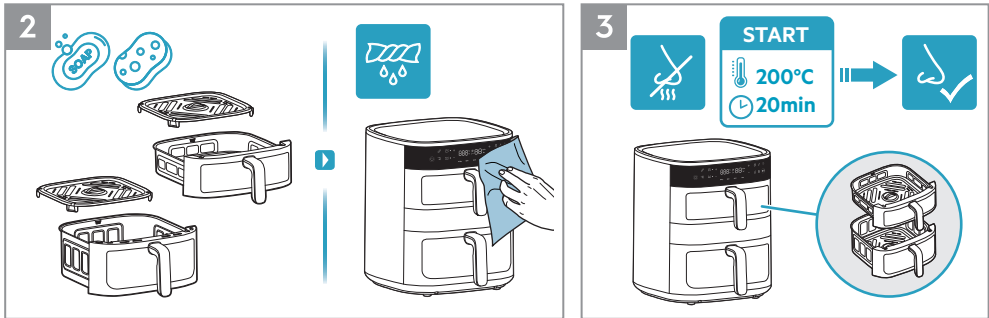

2. Pulire la teglia e la griglia con acqua tiepida e detersivo per piatti. Pulire l'interno e l'esterno dell'apparecchio con un panno morbido.

3. È normale che un'unità nuova emetta odori durante le prime volte che viene utilizzata. Per evitare questo problema, far funzionare la friggitrice ad aria vuota a 200 °C per 20 minuti prima del primo utilizzo.

! Precauzioni di sicurezza

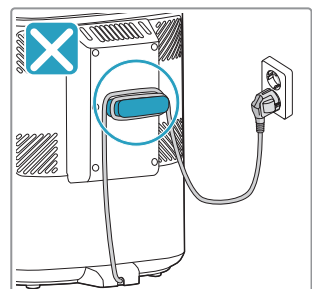
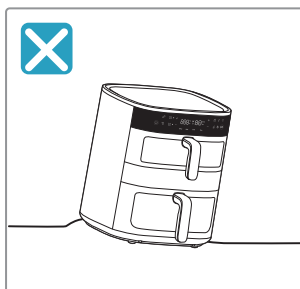
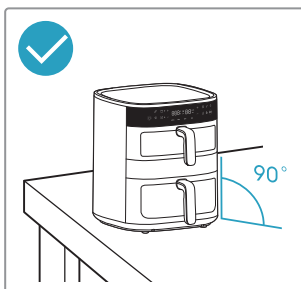
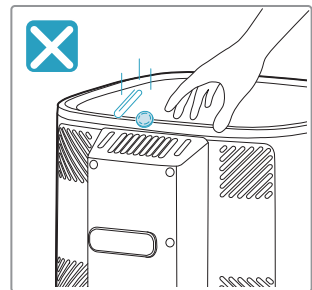
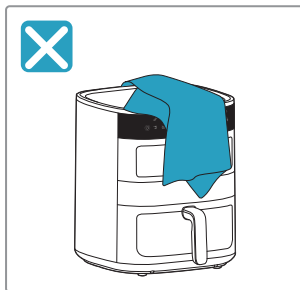
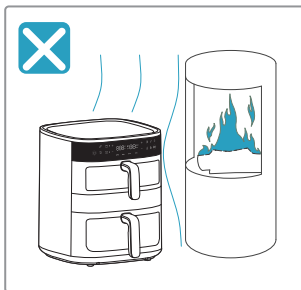

GB

BG

DE

ES

FR

GR

IT

PT

NL

CA

SE

FI



DK

NO





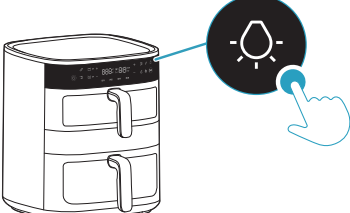
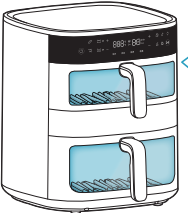





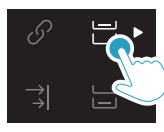



HU

AR

Controllo dell'illuminazione e conversione della scala di temperatura





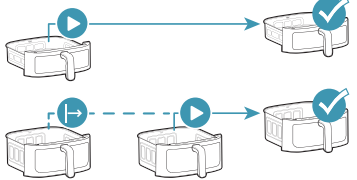









 <p>Controllo dell'illuminazione</p>		 <p>30 sec</p>
<p>°C/°F</p> <p>Conversione della scala di temperatura</p>	 <p>30 sec</p>	

Selezione del cestello

	 <p>4L</p>	 <p>7L</p>	
 <p>Cestello superiore</p>			
 <p>Cestello inferiore</p>			
 <p>Funzione Link</p>			
 <p>Funzione di fine sincronizzazione</p>			

GB
BG
DE
ES
FR
GR
IT
PT
NL
CA
SE
FI
DK
NO
HU
AR

Funzioni preimpostate

 AirFry					
AirFry	180°C	15min	60~200°C	1-99min	
	170°C	10min	60~200°C	1-99min	
	140°C	15min	60~200°C	1-99min	
	180°C	30min	60~200°C	1-99min	
	200°C	10min	60~200°C	1-99min	
Bake	170°C	15min	60~200°C	1-99min	
Grill	200°C	5min	60~200°C	1-99min	
Dry	80°C	5h	40~80°C	1-5h	

Prima della cottura

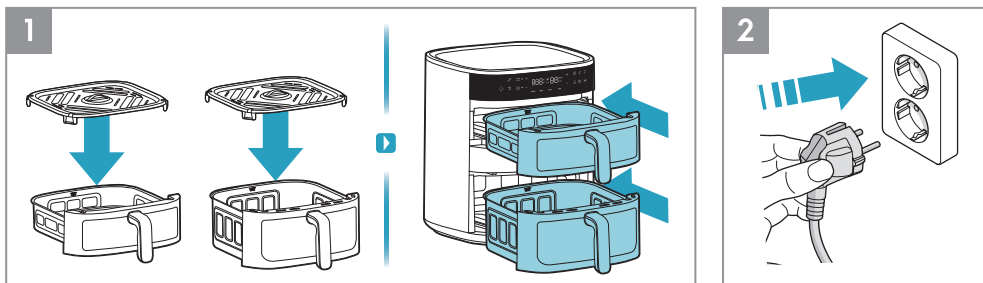

1. Prima di ogni cottura, posizionare la griglia nel cestello (non è necessario rimuovere il piedino in silicone resistente al calore della griglia) e spingere completamente il cestello nell'apparecchio.
2. Inserire la spina di alimentazione dalla presa di corrente.

GB
BG
DE
ES
FR
GR
IT
PT
NL
CA
SE
FI
DK
NO
HU
AR

Modalità d'uso - Cestello singolo

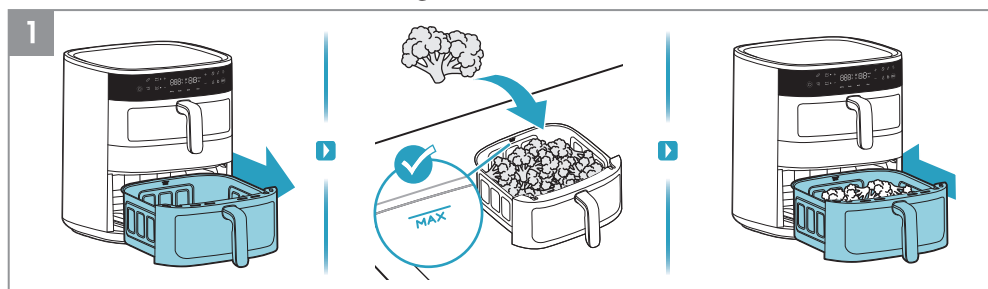

1. Estrarre un cestello e posizionarlo su una superficie stabile, inserire il cibo nel cestello, osservando l'indicazione di capacità "MAX". Quindi spingere completamente il cestello con il cibo all'interno dell'apparecchio.



2. Premere il pulsante On/Off. Selezionare prima il cestello con il cibo. Quindi selezionare il metodo di cottura desiderato, ad esempio la funzione Air Fry. Regola il tempo e la temperatura a tuo piacimento o seleziona una delle ricette preimpostate, ad esempio Verdure. Infine, premi il pulsante Riproduzione/Pausa.

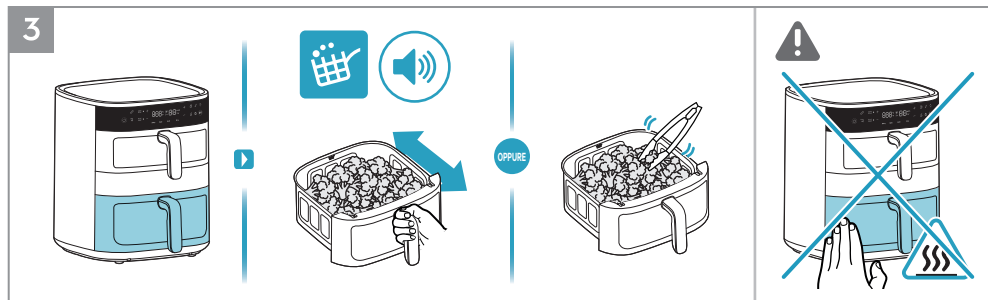

3. Quando l'icona "Promemoria agitazione" si illumina ed emette un segnale acustico durante la cottura, utilizza utensili resistenti al calore per girare il cibo una volta o agitalo leggermente con attenzione nel cestello.

⚠ **AVVERTENZA:** Non agitare energicamente il cestello per evitare schizzi di cibo e ustioni.

⚠ **AVVERTENZA:** Prestare attenzione alle superfici calde quando l'apparecchio è in funzione.

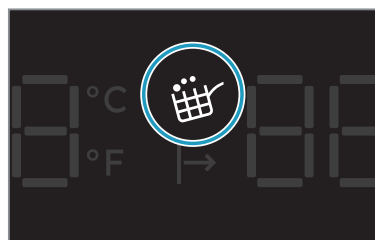

Promemoria agitazione

La funzione "Promemoria agitazione" si attiva durante la funzione Air Fry e le ricette preimpostate, come Verdure, Pesce, Cosce di pollo e Bistecca.

Quando è il momento di agitare o girare il cibo, l'icona "Promemoria agitazione" si illumina e lampeggia per un minuto, mentre un segnale acustico viene ripetuto per tre volte.

La funzione "Promemoria agitazione" non è obbligatoria, quindi la cottura continuerà normalmente anche se il cibo non viene girato o agitato.



4. Al termine della cottura, l'apparecchio emetterà un segnale acustico. Rimuovere con cautela il cestello e posizionarlo su una superficie resistente al calore. Scollegare l'apparecchio dopo l'uso.

⚠ AVVERTENZA: Dal cestello può fuoriuscire vapore caldo quando viene aperto a metà o alla fine della cottura. Assicurarsi che viso, braccia e mani siano lontani dal vapore quando lo si apre.

Modalità d'uso - Cestello superiore + inferiore

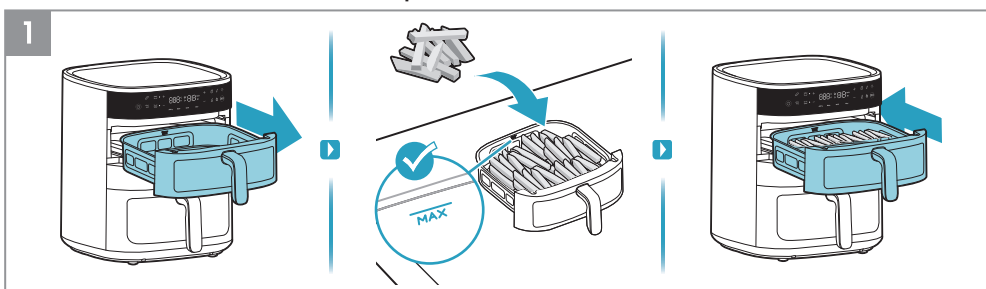

1. Innanzitutto, estrarre il cestello superiore e inserire il cibo, ad esempio patatine fritte.

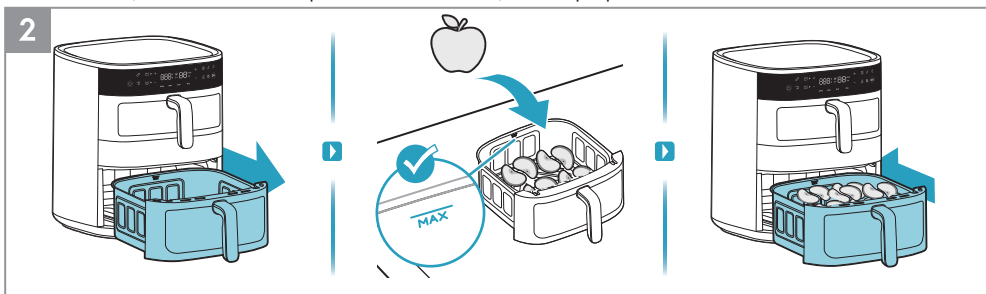

2. In secondo luogo, estrarre il cestello inferiore e inserire il cibo, ad esempio fette di mela.



3. Premere il pulsante On/Off. Selezionare prima il cestello superiore. Quindi selezionare il metodo di cottura desiderato, ad esempio la funzione Air Fry. Regola il tempo e la temperatura a tuo piacimento o seleziona una delle ricette preimpostate, ad esempio Verdure. Infine, premi il pulsante Riproduzione/Pausa.

GB
BG
DE
ES
FR
GR
IT
PT
NL
CA
SE
FI
DK
NO
HU
AR



4. Selezionare poi il cestello inferiore. Quindi selezionare il metodo di cottura desiderato, ad esempio la funzione Essiccazione. Regola il tempo e la temperatura a tuo piacimento. Infine, premi il pulsante Riproduzione/Pausa.

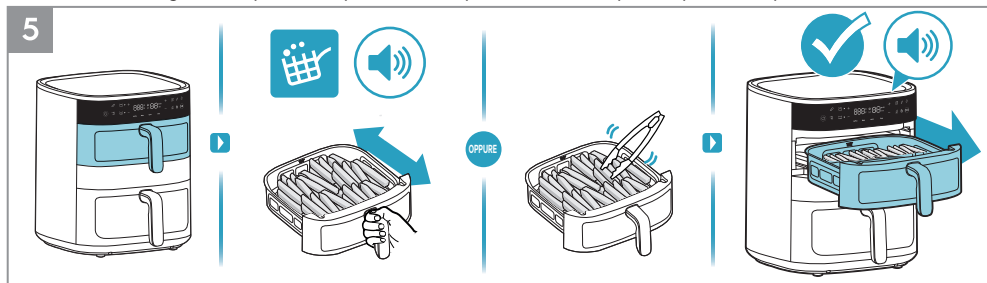

5. Quando l'icona "Promemoria agitazione" si illumina ed emette un segnale acustico durante la cottura, utilizza utensili resistenti al calore per girare il cibo una volta o agitalo leggermente con attenzione nel cestello. Al termine del tempo di cottura del cestello superiore, l'apparecchio emetterà un segnale acustico.

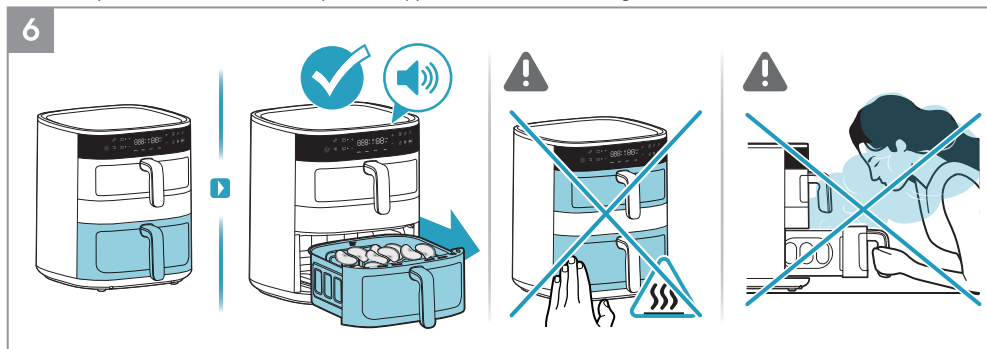

6. Al termine del tempo di cottura del cestello inferiore, l'apparecchio emetterà un segnale acustico.

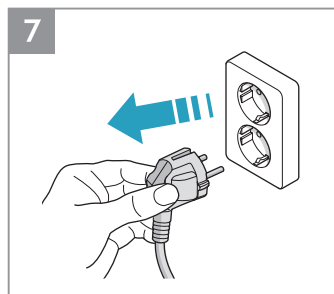

7. Scollegare l'apparecchio dopo l'uso.

Modalità d'uso - Funzione Link

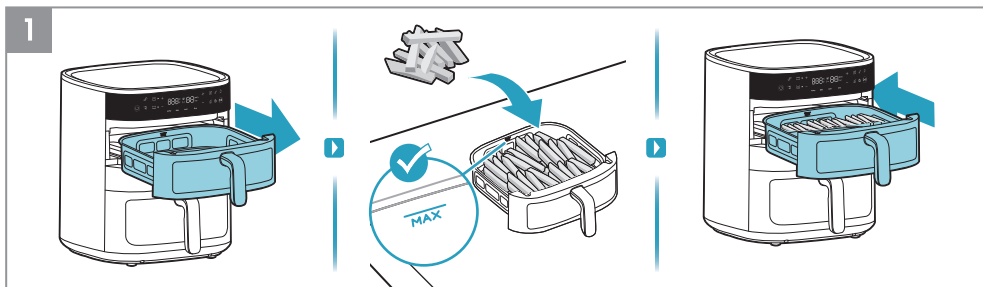

1. Innanzitutto, estrarre il cestello superiore e inserire il cibo, ad esempio patatine fritte.

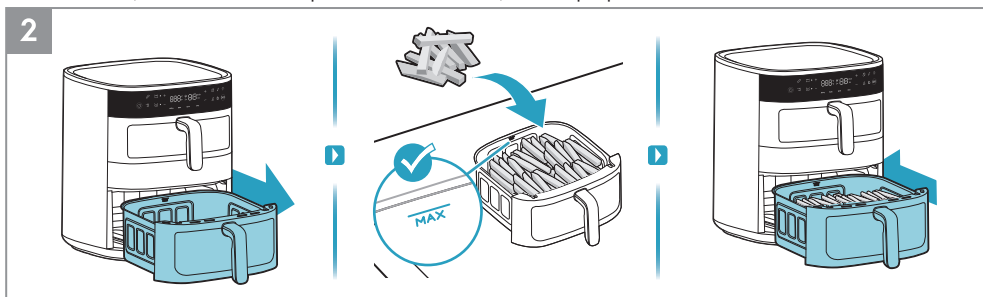

2. In secondo luogo, estrarre il cestello inferiore e inserire il cibo, ad esempio patatine fritte.



3. Premere il pulsante On/Off. Seleziona prima la funzione Link. Quindi selezionare il metodo di cottura desiderato, ad esempio la funzione Air Fry. Regola il tempo e la temperatura a tuo piacimento o seleziona una delle ricette preimpostate. Infine, premi il pulsante Riproduzione/Pausa.

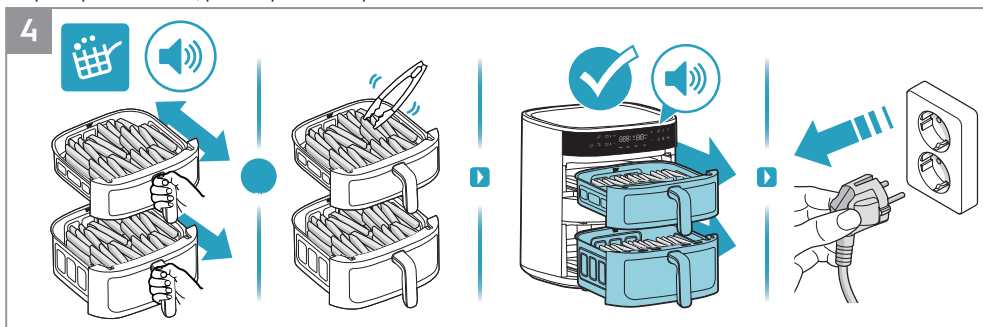

4. Quando l'icona "Promemoria agitazione" si illumina ed emette un segnale acustico durante la cottura, utilizza utensili resistenti al calore per girare il cibo una volta o agitalo leggermente con attenzione nel cestello. Al termine della cottura, l'apparecchio emetterà un segnale acustico. Scollegare l'apparecchio dopo l'uso.

Modalità d'uso - Funzione di fine sincronizzazione

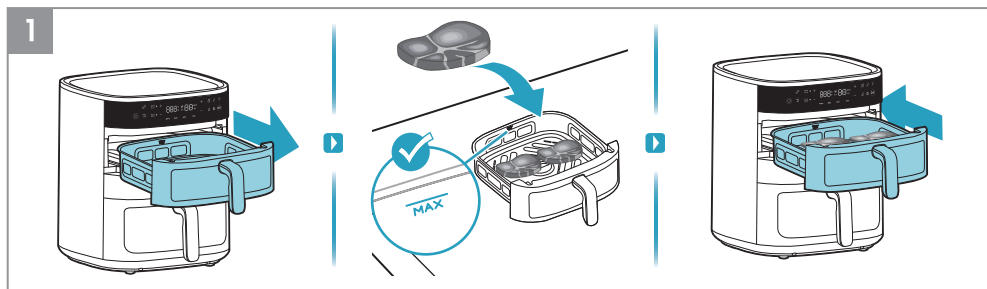

1. Innanzitutto, estrarre il cestello superiore e inserire il cibo, ad esempio bistecca.

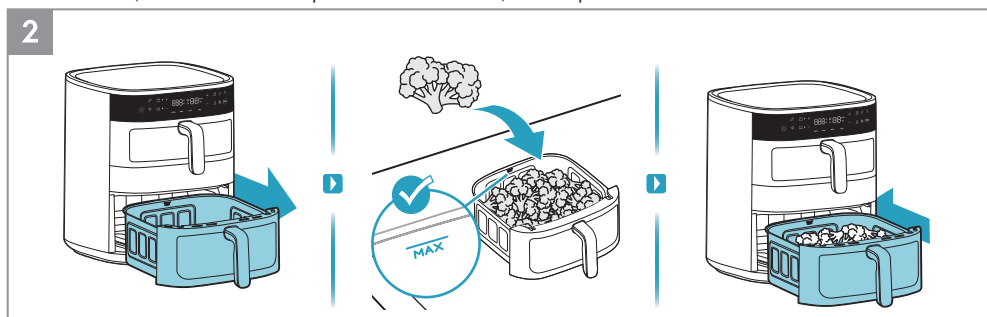

2. In secondo luogo, estrarre il cestello inferiore e inserire il cibo, ad esempio broccoli.

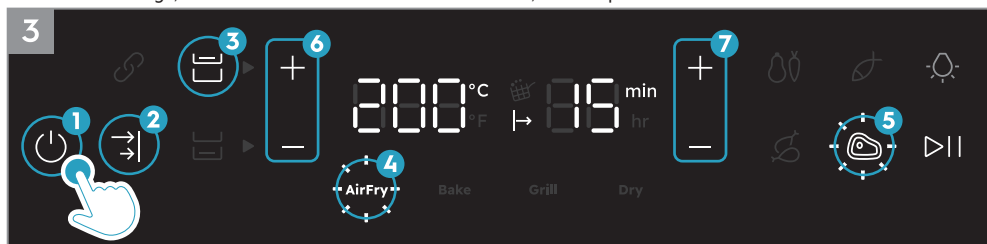

3. Premere il pulsante On/Off. Selezionare la Funzione di fine sincronizzazione. Selezionare prima il cestello superiore, quindi il metodo di cottura desiderato, ad esempio la funzione Air Fry. Regola il tempo e la temperatura a tuo piacimento o seleziona una delle ricette preimpostate, ad esempio Bistecca.



4. Quindi selezionare il cestello inferiore, quindi il metodo di cottura desiderato, ad esempio la funzione Air Fry. Regola il tempo e la temperatura a tuo piacimento o seleziona una delle ricette preimpostate. Infine, premi il pulsante Riproduzione/Pausa.

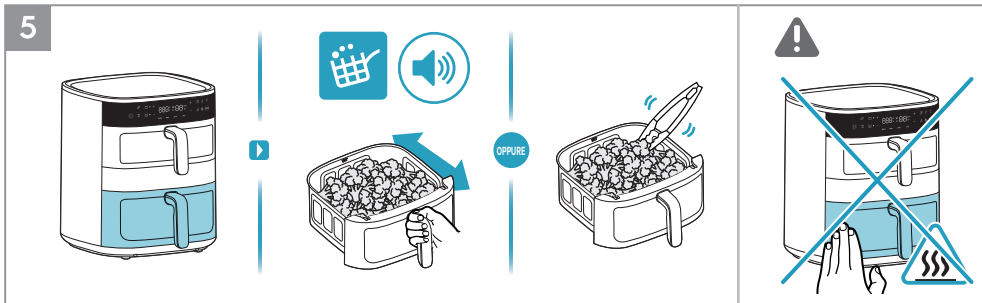

5. Innanzitutto, il cestello inferiore con il tempo di cottura più lungo avrà la priorità per la cottura. Quando l'icona "Promemoria agitazione" si illumina ed emette un segnale acustico durante la cottura, utilizza utensili resistenti al calore per girare il cibo una volta o agitalo leggermente con attenzione nel cestello.

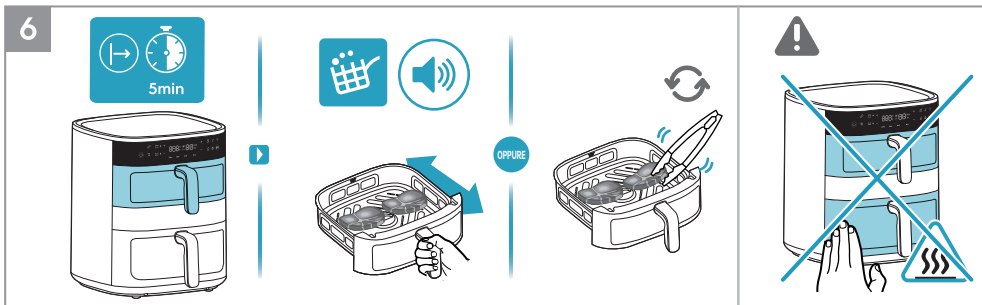

6. In secondo luogo, il cestello superiore con il tempo di cottura più breve inizierà la cottura. Quando l'icona "Promemoria agitazione" si illumina ed emette un segnale acustico durante la cottura, utilizza utensili resistenti al calore per girare il cibo una volta o agitalo leggermente con attenzione nel cestello.

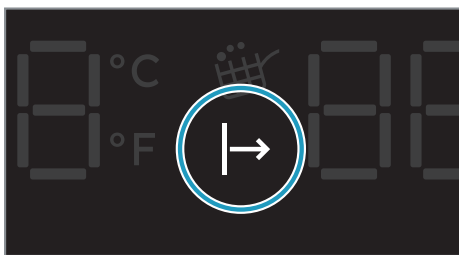

Indicatore di in attesa di cottura

Quando la "Funzione di fine sincronizzazione" è attivata, il cestello con il tempo di cottura più breve attenderà la cottura fino a quando il cestello con il tempo di cottura più lungo non avrà terminato la cottura per un po', in modo che entrambi i cestelli possano terminare la cottura contemporaneamente. Durante questo periodo, l'"indicatore di in attesa di cottura" si illuminerà fino all'inizio della cottura.

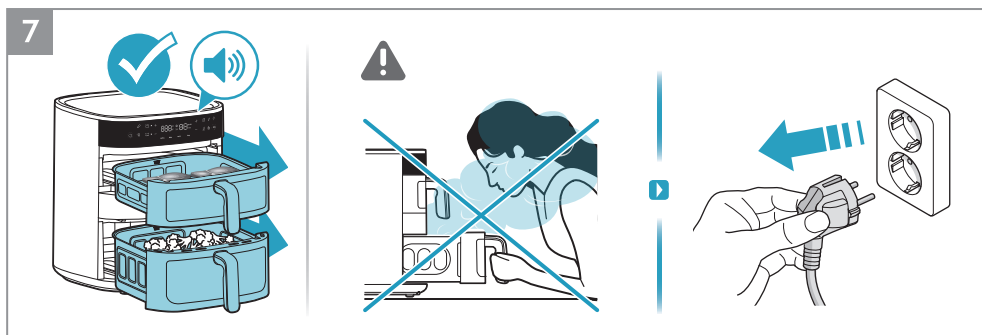

7. Al termine della cottura, l'apparecchio emetterà un segnale acustico. Scollegare l'apparecchio dopo l'uso.

Pulizia

1

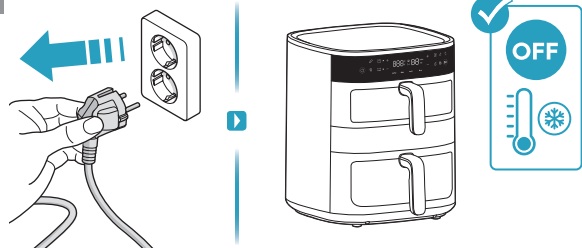

2



1. Scollegare sempre l'apparecchio e attendere che si raffreddi prima di pulirlo.
2. Pulire l'esterno dell'apparecchio con un panno morbido.

3

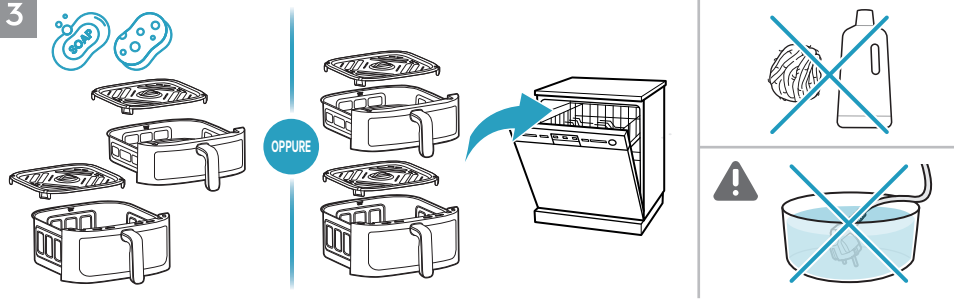

3. Pulire la pentola e la griglia con acqua tiepida e detersivo per piatti, oppure lavarle in lavastoviglie.

NOTA: Evitare l'uso di prodotti abrasivi o utensili metallici per proteggere il rivestimento antiaderente.

AVVERTENZA: Non immergere mai il prodotto, il cavo o la spina in acqua o altri liquidi.



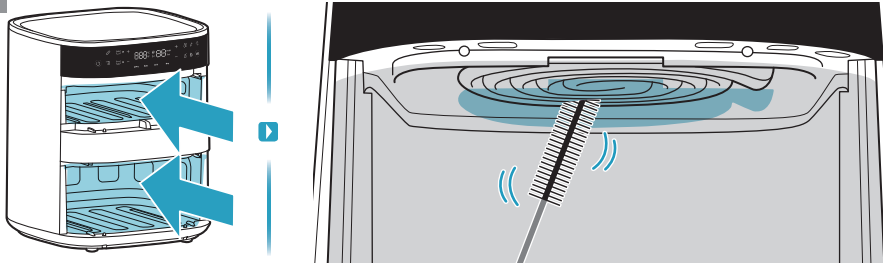









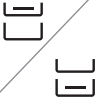

























4























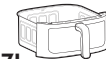

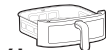
4. Pulire l'elemento riscaldante con una spazzola.

NOTA: Assicurarsi che l'apparecchio si sia completamente raffreddato prima di pulire l'elemento riscaldante.

Guida alla cottura

							
AirFry	7mm/10mm 	4L 	400g	180 °C	18min		
		7L 	400g	180 °C	18min		
AirFry		4L 	400g	170 °C	8min		
		7L 	400g	170 °C	10min		
AirFry		4L 	400g/2pz	140 °C	15min		
		7L 	400g/2pz	140 °C	15min		
AirFry		4L 	1000g/8pz	180 °C	28min		
		7L 	1000g/8pz	180 °C	28min		
AirFry		4L 	400g/2pz	200 °C	10min		
		7L 	400g/2pz	200 °C	10min		
AirFry		4L 	220g/6inches	160 °C	12min		
		7L 	220g/6inches	160 °C	14min		

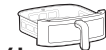
- GB
- BG
- DE
- ES
- FR
- GR
- IT**
- PT
- NL
- CA
- SE
- FI
- DK
- NO
- HU
- AR

Recipe							
AirFry		 7L	1200g	180 °C	55min		
AirFry		 7L	400g/9pz	160 °C	20min		
Grill		 4L	180g/4pz	180 °C	8min		
		 7L	180g/4pz	180 °C	9min		
Dry		 4L	180g	80 °C	3h		
		 7L	180g	80 °C	3h		
Dry		 4L	200g	80 °C	3h		
		 7L	200g	80 °C	3h		

GB
BG
DE
ES
FR
GR
IT
PT
NL
CA
SE
FI
DK
NO
HU
AR

Cosa fare se...

Problema	Controllare se...
Non è possibile accendere o far funzionare l'apparecchio.	<ul style="list-style-type: none"> • L'apparecchio è correttamente collegato alla rete elettrica. • I cestelli sono nella posizione corretta. Assicurarsi che siano completamente inseriti nell'apparecchio per consentire l'alimentazione elettrica. • Il tempo di cottura è impostato.
Non è possibile inserire il cestello nell'apparecchio.	<ul style="list-style-type: none"> • Il cestello è riempito oltre la sua capacità massima. • Il cestello è posizionato correttamente. Deve scattare quando lo si inserisce nell'unità. • C'è un oggetto sotto il cestello che impedisce la corretta chiusura.
Dall'apparecchio fuoriesce fumo bianco.	<ul style="list-style-type: none"> • Il cibo preparato è troppo unto. • Il cestello, la griglia e l'elemento riscaldante sono puliti.
Il display visualizza E1	<ul style="list-style-type: none"> • Circuito aperto nel cestello superiore.
Il display visualizza E2	<ul style="list-style-type: none"> • Cortocircuito nel cestello superiore.
Il display visualizza E3	<ul style="list-style-type: none"> • Circuito aperto nel cestello inferiore.
Il display visualizza E4	<ul style="list-style-type: none"> • Cortocircuito nel cestello inferiore.
Il display visualizza E5	<ul style="list-style-type: none"> • Errore di comunicazione con la scheda di controllo.
Il display visualizza E6	<ul style="list-style-type: none"> • Errore di comunicazione con la scheda di alimentazione.

*Se il display mostra codici di errore, l'apparecchio deve essere riparato da un Centro di Assistenza.

Dati tecnici

Prodotto	Air Fryer
Modello	AAFD11B
Voltaggio (V~)	220 V ~ 240 V
Potenza (W)	2700 W
Frequenza (Hz)	50 ~ 60 Hz
Watt	4 L + 7 L

GB

BG

DE

ES

FR

GR

IT

PT

NL

CA

SE

FI

DK

NO

HU

AR



Manual do utilizador

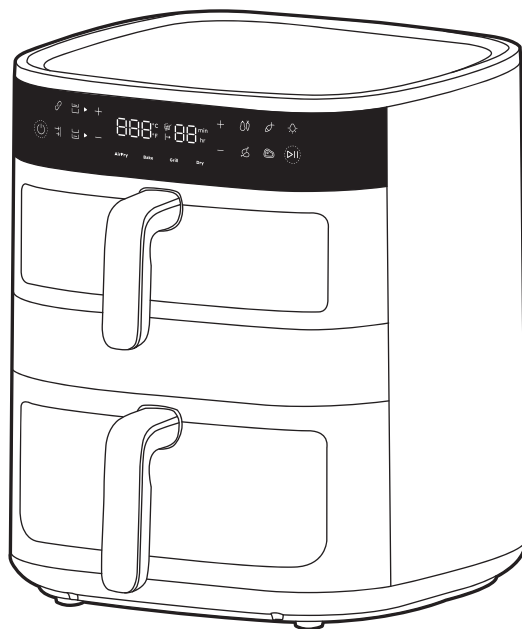

800 Air Fryer Dual

Visão geral

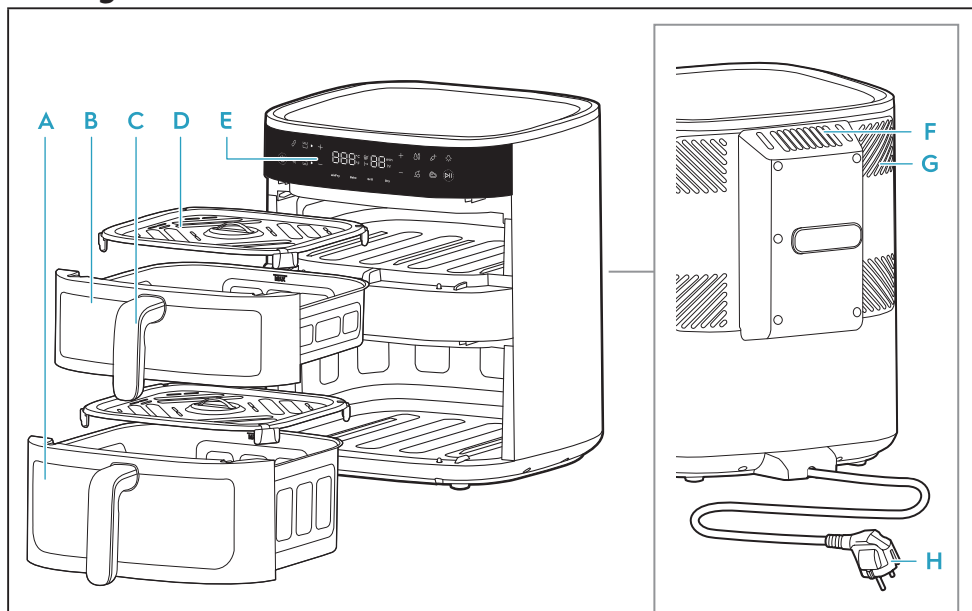

- | | | | |
|-------------------------------|------------------------|-----------------------------|-----------------------------------|
| A Cesto inferior (7 L) | C Pega do cesto | E Painel de controlo | G Sistema de arrefecimento |
| B Cesto superior (4 L) | D Grelha | F Saída de ar | H Cabo de alimentação |

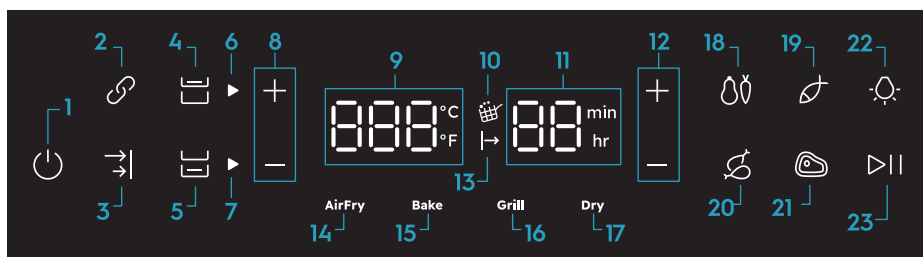

- | | | | |
|--------------------------------|--|---|----------------------|
| 1. Ligar / desligar | 7. Indicador do cesto inferior | 11. Indicador do tempo (Fritar a ar: 1 min - 99 min, Desidratar: 1 h - 5 h) | 18. Vegetais |
| 2. Função Ligação | 8. Controlo da temperatura | 12. Controlo do tempo | 19. Peixe |
| 3. Função Fim de Sincronização | 9. Indicador da temperatura (40 °C - 200 °C) | 13. Cocção em espera | 20. Bife |
| 4. Controlo do cesto superior | 10. Aviso para Agitar | 14. Função Fritar a Ar | 21. Steak |
| 5. Controlo do cesto inferior | | 15. Função Cozer | 22. Controlo da luz |
| 6. Indicador do cesto superior | | 16. Função Grelhar | 23. Iniciar / Pausar |
| | | 17. Função Desidratar | |

Antes da primeira utilização

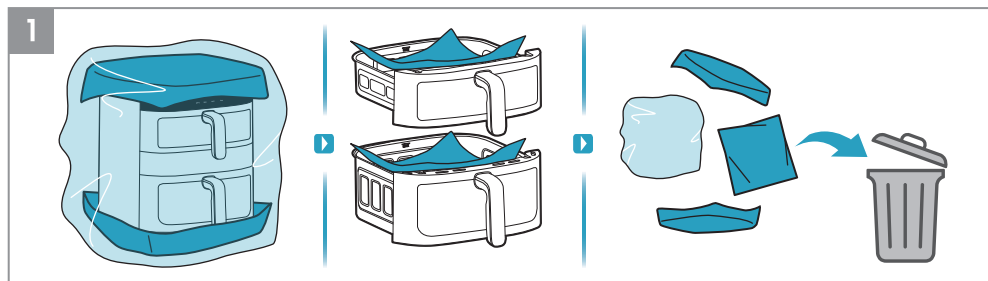

1. Remova todo material de embalagem e de proteção.

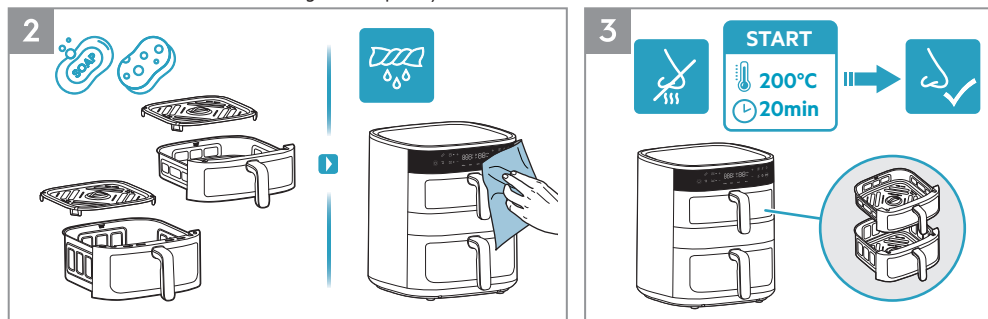



2. Limpe a frigideira e a grelha com água morna e detergente da louça. Limpe o interior e o exterior do aparelho com um pano macio.

3. É normal que uma unidade nova liberte odores nas primeiras utilizações. Para evitar esta situação, ligue a fritadeira vazia a 200 °C durante 20 minutos antes da primeira utilização.

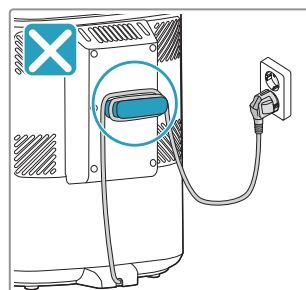
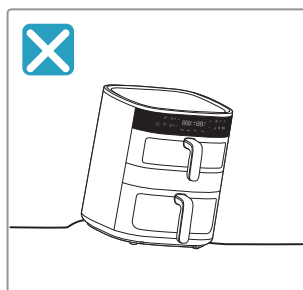
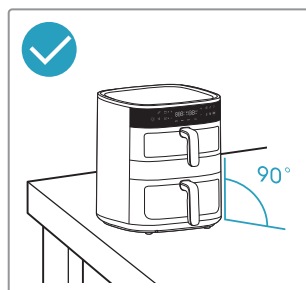
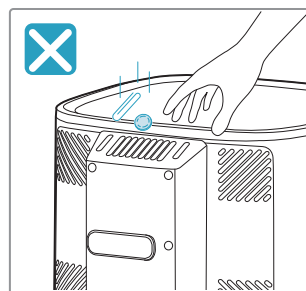
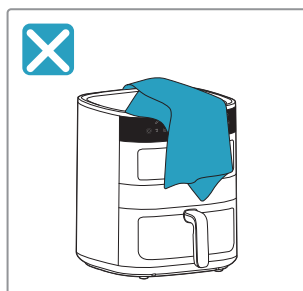



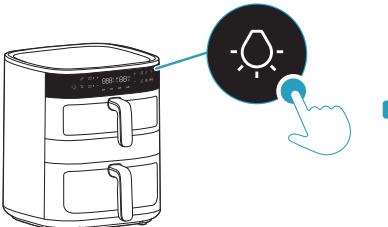
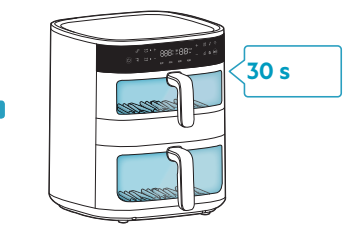

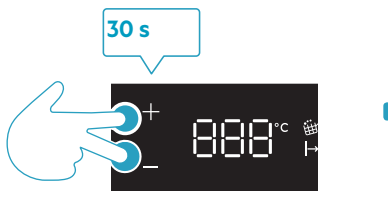
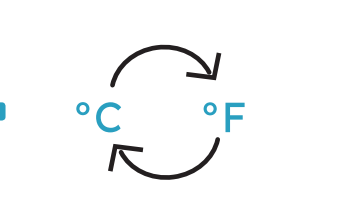







! Precauções de segurança



Controlo da luz e conversão da escala de temperatura





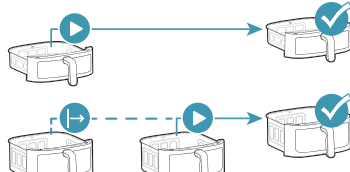









 <p>Controlo da luz</p>		
 <p>Conversão da escala de temperatura</p>		

Seleção do cesto

	 <p>4L</p>	 <p>7L</p>	
 <p>Cesto superior</p>			
 <p>Cesto inferior</p>			
 <p>Função Ligação</p>			
 <p>Função Fim de Sincronização</p>			

- GB
- BG
- DE
- ES
- FR
- GR
- IT
- PT**
- NL
- CA
- SE
- FI
- DK
- NO
- HU
- AR

Funções predefinidas

 Air Fry					
Air Fry	180°C	15min	60~200°C	1~99min	
	170°C	10min	60~200°C	1~99min	
	140°C	15min	60~200°C	1~99min	
	180°C	30min	60~200°C	1~99min	
	200°C	10min	60~200°C	1~99min	
Bake	170°C	15min	60~200°C	1~99min	
Grill	200°C	5min	60~200°C	1~99min	
Dry	80°C	5h	40~80°C	1~5h	

Antes de cozinhar

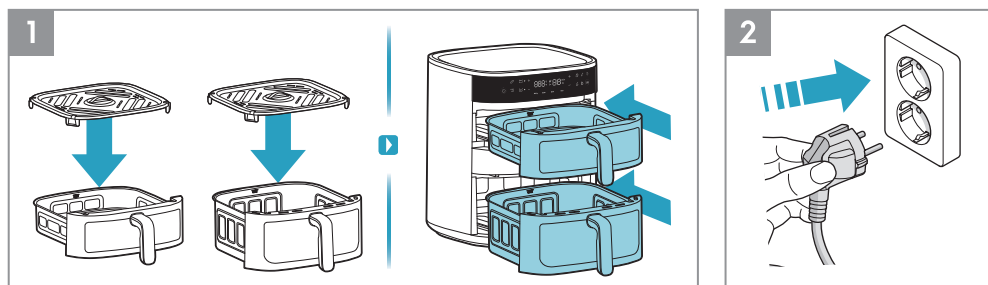

1. Antes de cada cocção, coloque a grelha no cesto (não precisa de remover a base de silicone resistente ao calor da grelha) e introduza completamente o cesto no aparelho.
2. Introduza a ficha de alimentação na tomada elétrica.

Como utilizar - cesto único

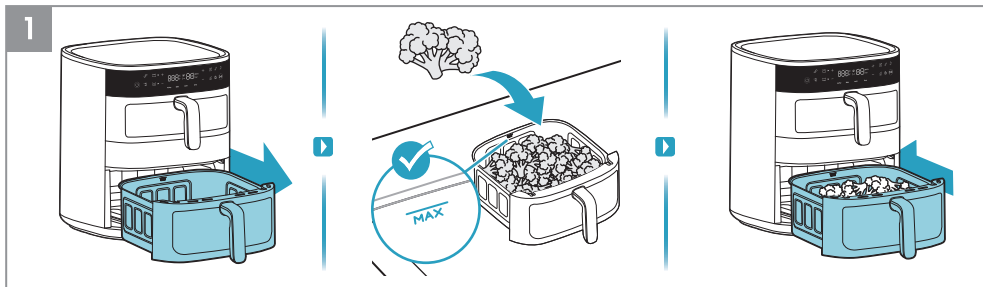

1. Extraia um cesto, coloque-o sobre uma superfície estável e introduza os alimentos no cesto, respeitando a indicação de capacidade "MAX." Em seguida, reintroduza o cesto com alimentos no aparelho.

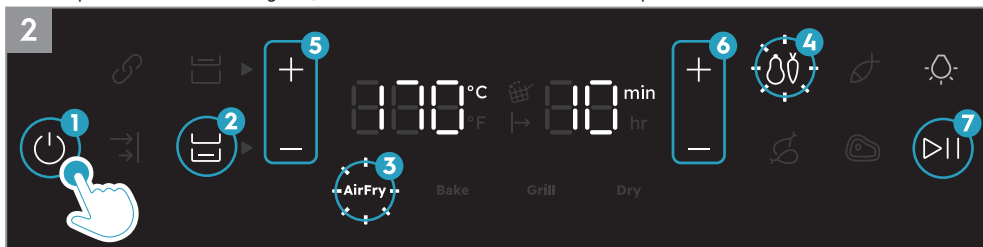

2. Carregue no botão de Ligar / Desligar. Primeiro, selecione o cesto com alimentos. Em seguida, selecione o método de cocção pretendido como, por exemplo, a função Fritar a Ar. Regule o tempo e a temperatura como quiser ou selecione uma das receitas predefinidas como, por exemplo, Vegetais. Por fim, prima o botão Iniciar / Pausar.

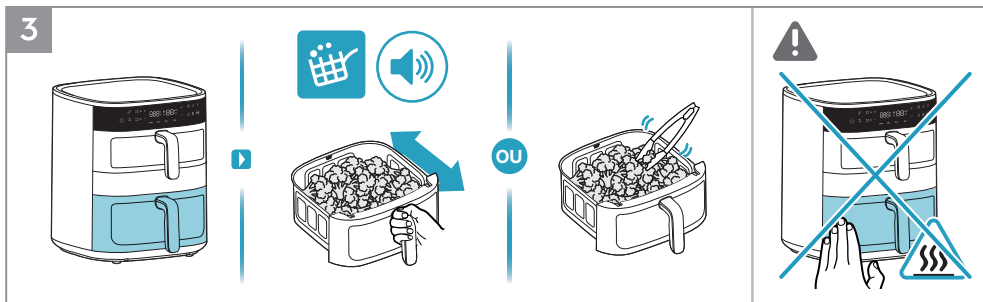

3. Quando o ícone "Aviso para Agitar" se acender e emitir um sinal sonoro durante o processo de cocção, utilize ferramentas resistentes ao calor para dar a volta aos alimentos ou agite, levemente e com cuidado, os alimentos no cesto de fritura.

⚠ **CUIDADO:** Não agite com o cesto de fritura demasiada força para evitar salpicos de alimentos e queimaduras.

⚠ **CUIDADO:** Tenha atenção às superfícies quentes quando estiver a utilizar o aparelho.

Aviso para Agitar

O "Aviso para Agitar" é ativado durante a função Fritar a Ar e as receitas predefinidas como Vegetais, Peixe, pernas de Frango e Bife.

Quando for o momento de mexer ou virar os alimentos, o ícone de "Aviso para Agitar" acende-se e pisca durante um minuto, ao mesmo tempo que é emitido um sinal sonoro três vezes.

O "Aviso para Agitar" não implica uma ação obrigatória; portanto, a cocção irá continuar normalmente, mesmo que não dê a volta nem mexa os alimentos.

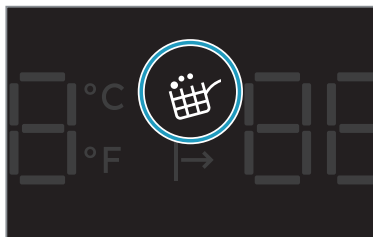

GB

BG

DE

ES

FR

GR

IT

PT

NL

CA

SE

FI

DK

NO

HU

AR

4

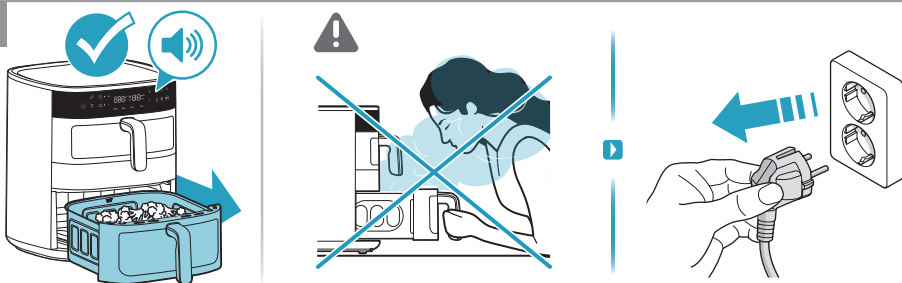

4. No final do tempo de cocção, o aparelho emite um sinal sonoro. Retire o cesto com cuidado e coloque-o numa superfície resistente ao calor. Desligue o aparelho da corrente elétrica depois de o utilizar.

⚠ **CUIDADO:** O cesto pode libertar vapor quente se for extraído a meio ou no fim da cocção. Certifique-se de que o rosto, os braços e as mãos estão afastados do vapor quando o extrair.

Como utilizar - Cesto superior + inferior

1

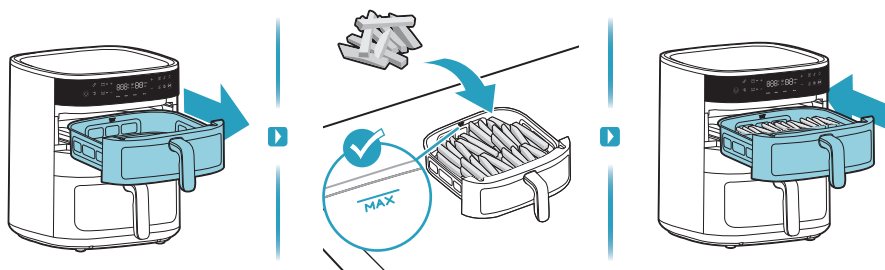

1. Primeiro, retire o cesto superior e coloque nele os alimentos como, por exemplo, batatas fritas.

2

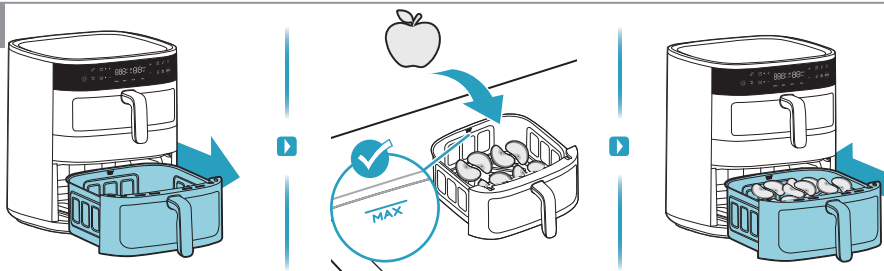

2. Em seguida, retire o cesto inferior e coloque nele os alimentos como, por exemplo, fatias de maçã.

3



3. Carregue no botão de Ligar / Desligar. Primeiro, seleccione o cesto superior. Em seguida, seleccione o método de cocção pretendido como, por exemplo, a função Fritar a Ar. Regule o tempo e a temperatura como quiser ou seleccione uma das receitas predefinidas como, por exemplo, Vegetais. Por fim, prima o botão Iniciar / Pausar.



4. Depois, seleccione o cesto inferior. Em seguida, seleccione o método de cocção pretendido como, por exemplo, a função Desidratar. Regule o tempo e a temperatura como quiser. Por fim, prima o botão Iniciar / Pausar.

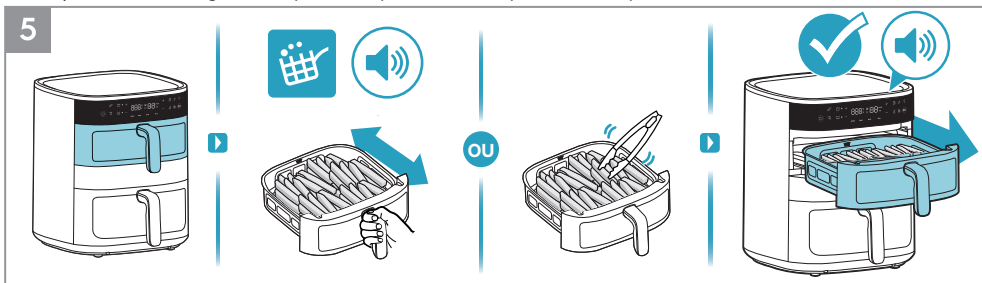

5. Quando o ícone “Aviso para Agitar” se acender e emitir um sinal sonoro durante o processo de cocção, utilize ferramentas resistentes ao calor para dar a volta aos alimentos ou agite, ligeiramente e com cuidado, os alimentos no cesto de fritura. No final do tempo de cocção no cesto superior, o aparelho emite um sinal sonoro.

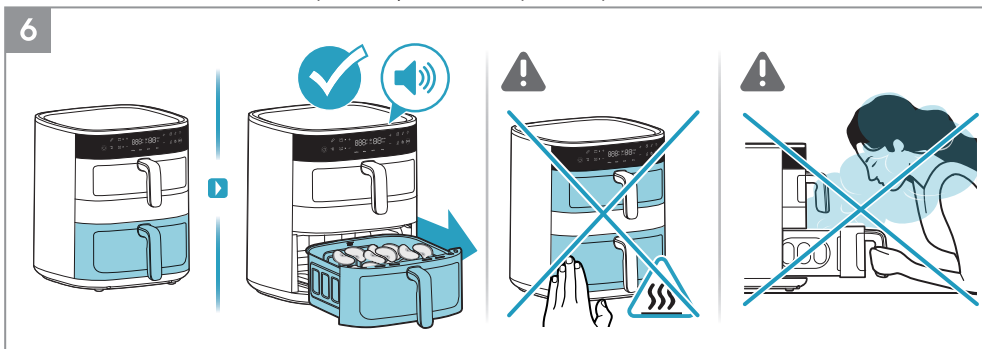

6. No final do tempo de cocção do cesto inferior, o aparelho emite um sinal sonoro.

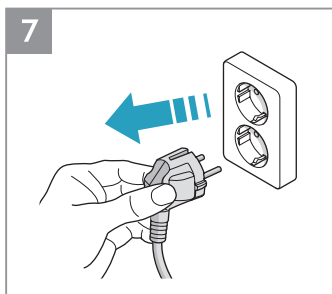

7. Desligue o aparelho da corrente elétrica depois de o utilizar.

GB
BG
DE
ES
FR
GR
IT
PT
NL
CA
SE
FI
DK
NO
HU
AR

Como utilizar - Função ligação

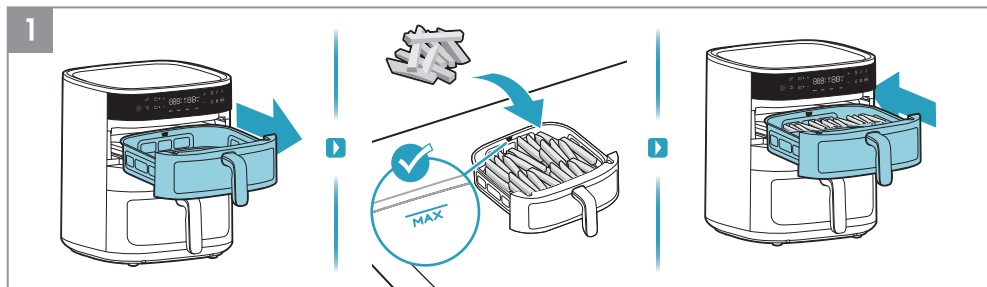

1. Primeiro, retire o cesto superior e coloque nele os alimentos como, por exemplo, batatas fritas.

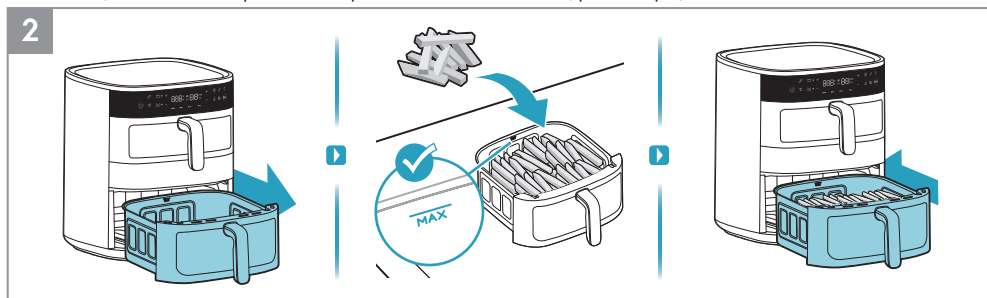

2. Em seguida, retire o cesto inferior e coloque nele os alimentos como, por exemplo, batatas fritas.



3. Carregue no botão de Ligar / Desligar. Primeiro, selecione a função Ligação. Em seguida, selecione o método de cocção pretendido como, por exemplo, a função Fritar a Ar. Regule o tempo e a temperatura como quiser ou selecione uma das receitas predefinidas. Por fim, prima o botão Iniciar / Pausar.

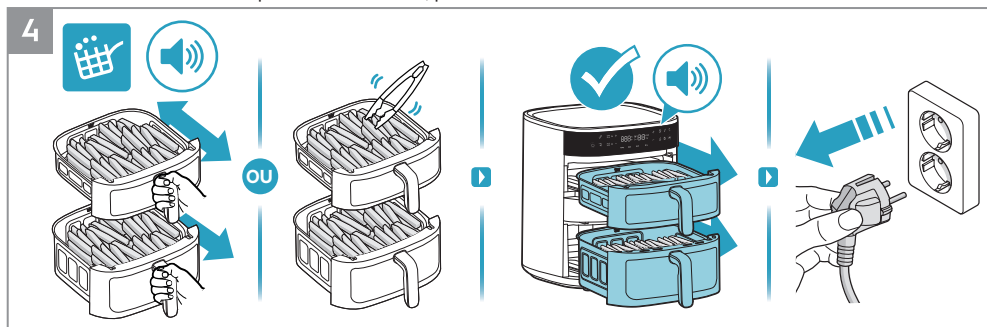

4. Quando o ícone “Aviso para Agitar” se acender e emitir um sinal sonoro durante o processo de cocção, utilize ferramentas resistentes ao calor para dar a volta aos alimentos ou agite, ligeiramente e com cuidado, os alimentos no cesto de fritura. No final do tempo de cocção, o aparelho emite um sinal sonoro. Desligue o aparelho da corrente elétrica depois de o utilizar.

Como utilizar - Função Fim de Sincronização

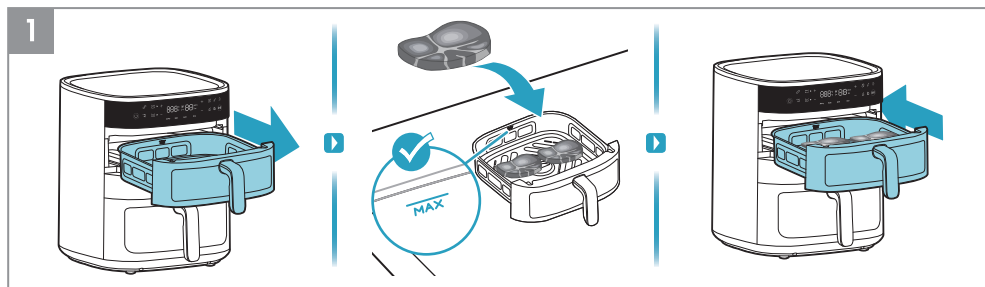

1. Primeiro, retire o cesto superior e coloque nele os alimentos como, por exemplo, bife.

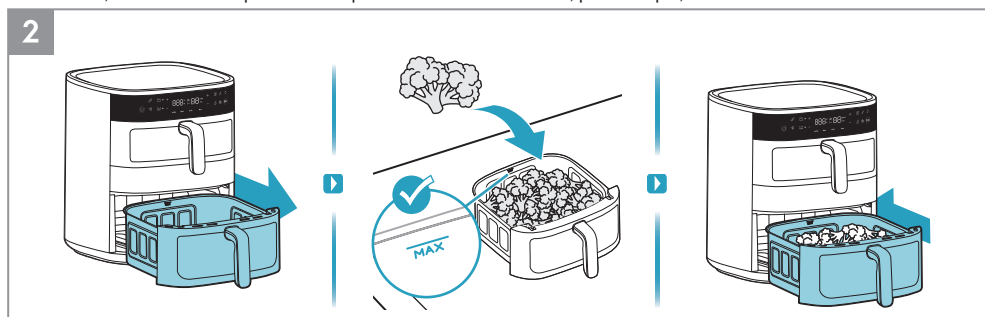

2. Em seguida, retire o cesto inferior e coloque nele os alimentos como, por exemplo, brócolos.



3. Carregue no botão de Ligar / Desligar. Selecione a função Fim de Sincronização. Primeiro, selecione o cesto superior e, em seguida, o método de cocção pretendido como, por exemplo, a função Fritar a Ar. Regule o tempo e a temperatura como quiser ou selecione uma das receitas predefinidas, por exemplo, Bife.



4. E agora selecione o cesto inferior e o método de cocção pretendido como, por exemplo, a função Fritar a Ar. Regule o tempo e a temperatura como quiser ou selecione uma das receitas predefinidas. Por fim, prima o botão Iniciar / Pausar.

GB

BG

DE

ES

FR

GR

IT

PT

NL

CA

SE

FI

DK

NO

HU

AR

5

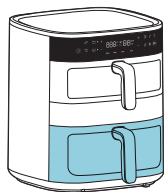

OU



5. Primeiro, o cesto inferior com um tempo definido superior será priorizado para cozinhar. Quando o ícone “Aviso para Agitar” se acender e emitir um sinal sonoro durante o processo de cocção, utilize ferramentas resistentes ao calor para dar a volta aos alimentos ou agite, ligeiramente e com cuidado, os alimentos no cesto de fritura.

6

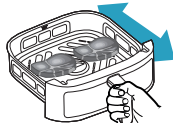
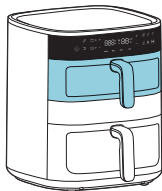

OU

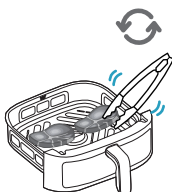

6. Depois, o cesto superior com um tempo definido inferior irá iniciar cocção. Quando o ícone “Aviso para Agitar” se acender e emitir um sinal sonoro durante o processo de cocção, utilize ferramentas resistentes ao calor para dar a volta aos alimentos ou agite, ligeiramente e com cuidado, os alimentos no cesto de fritura.

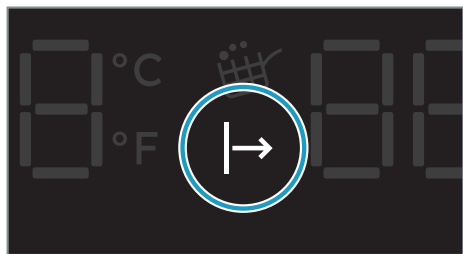

Indicador de Cocção em Espera

Quando a “função Fim de Sincronização” estiver ativada, o cesto com o tempo de cocção inferior aguarda para iniciar a cocção até que o cesto com o tempo de cocção superior efetue a cocção durante algum tempo, para que ambos os cestos possam terminar a cocção em simultâneo. Durante este período, o “indicador de Cocção em Espera” acende-se até que a cocção seja iniciada.

7

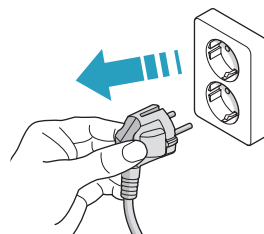
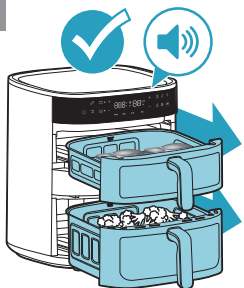

7. No final do tempo de cocção, o aparelho emite um sinal sonoro. Desligue o aparelho da corrente elétrica depois de o utilizar.

Limpeza

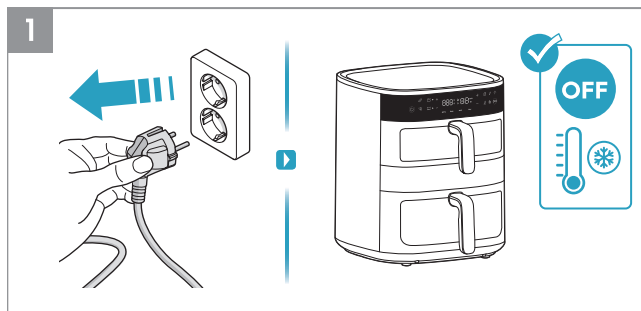

1. Desligue sempre o aparelho da corrente elétrica e aguarde até que arrefeça antes de o limpar.
2. Limpe o exterior do aparelho com um pano macio.

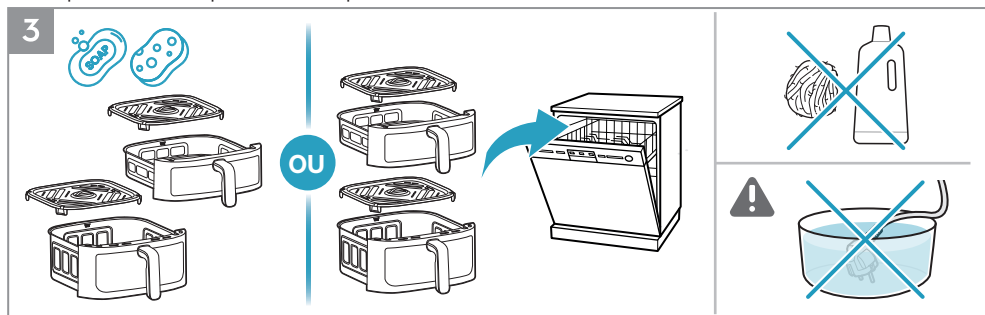
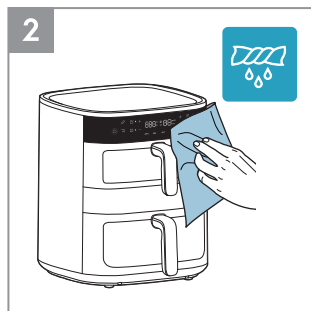

3. Limpe a frigideira e a grelha com água quente e detergente da louça; também pode colocá-las na máquina de lavar louça.

⚠NOTA: Evite a utilização de produtos de limpeza abrasivos ou de ferramentas metálicas para proteger o revestimento antiaderente.

CUIDADO: Nunca mergulhe o produto, o cabo ou a ficha elétrica em água ou noutro líquido.

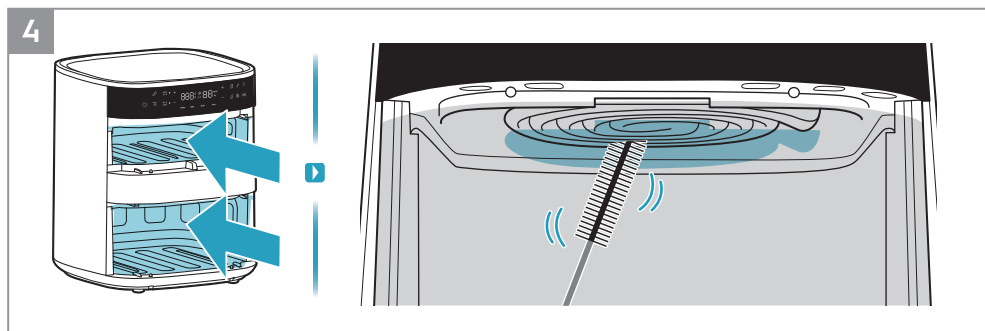

























4. Limpe o elemento de aquecimento com uma escova de limpeza.

NOTA: Certifique-se de que o aparelho está totalmente frio antes de limpar o elemento de aquecimento.

Guia de cozinha

Recipe							
AirFry	7mm/10mm 	4L	400g	180 °C	18min		
		7L	400g	180 °C	18min		
AirFry		4L	400g	170 °C	8min		
		7L	400g	170 °C	10min		
AirFry		4L	400g/2pçs.	140 °C	15min		
		7L	400g/2pçs.	140 °C	15min		
AirFry		4L	1000g/8pçs.	180 °C	28min		
		7L	1000g/8pçs.	180 °C	28min		
AirFry		4L	400g/2pçs.	200 °C	10min		
		7L	400g/2pçs.	200 °C	10min		
AirFry		4L	220g/6cm	160 °C	12min		
		7L	220g/6cm	160 °C	14min		

GB
BG
DE
ES
FR
GR
IT
PT
NL
CA
SE
FI
DK
NO
HU
AR

							
AirFry		 7L	1200g	180 °C	55min		
AirFry		 7L	400g/9pçs.	160 °C	20min		
Grill		 4L	180g/4pçs.	180 °C	8min		
		 7L	180g/4pçs.	180 °C	9min		
Dry		 4L	180g	80 °C	3h		
		 7L	180g	80 °C	3h		
Dry		 4L	200g	80 °C	3h		
		 7L	200g	80 °C	3h		

- GB
- BG
- DE
- ES
- FR
- GR
- IT
- PT**
- NL
- CA
- SE
- FI
- DK
- NO
- HU
- AR

O que fazer se...

Problema	Verificar se...
Não conseguir ativar ou utilizar o aparelho.	<ul style="list-style-type: none">• O aparelho está ligado corretamente à alimentação elétrica.• Os cestos estão na posição correta. Certifique-se de que estão completamente inseridos no aparelho para permitir a alimentação elétrica.• O tempo de cocção está definido.
Não conseguir introduzir o cesto no aparelho.	<ul style="list-style-type: none">• A capacidade do cesto foi ultrapassada.• O cesto está colocado corretamente. Deve emitir um estalido ao ser colocado na unidade.• Existe um objeto sob o cesto a impedir que feche corretamente.
O aparelho liberta fumo branco.	<ul style="list-style-type: none">• A comida preparada é demasiado oleosa.• O cesto, a grelha e o elemento de aquecimento estão limpos.
O visor apresenta E1	<ul style="list-style-type: none">• Circuito aberto do cesto superior.
O visor apresenta E2	<ul style="list-style-type: none">• Curto-circuito do cesto superior.
O visor apresenta E3	<ul style="list-style-type: none">• Circuito aberto do cesto inferior.
O visor apresenta E4	<ul style="list-style-type: none">• Curto-circuito no cesto inferior.
O visor apresenta E5	<ul style="list-style-type: none">• Falha de comunicação da PCBA de controlo.
O visor apresenta E6	<ul style="list-style-type: none">• Falha de comunicação da PCBA de alimentação.

* Caso o visor apresente códigos de erro, o aparelho deve ser reparado por um Centro de Assistência Técnica.

Dados técnicos

Produto	Fritadeira a ar
Modelo	AAFD11B
Tensão (V~)	220 V ~ 240 V
Potência (W)	2700 W
Frequência (Hz)	50 ~ 60 Hz
Capacidade	4 L + 7 L



Handleiding

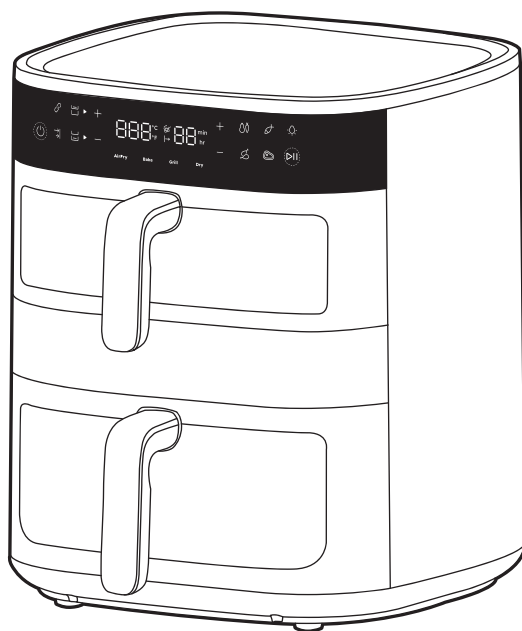

800 Air Fryer Dual

Algemene overzicht

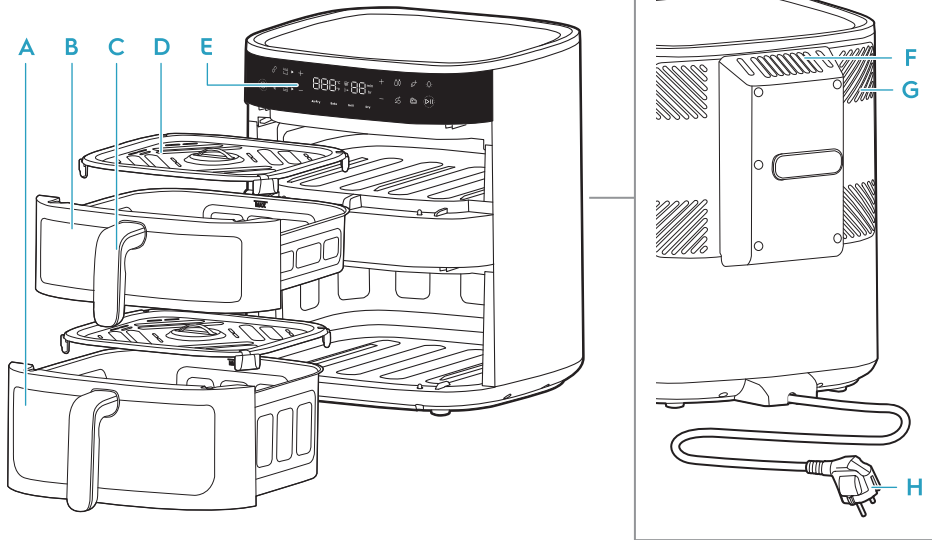

A Onderste mand (7 l)	C Mandhandvat	E Bedieningspaneel	G Koelsysteem
B Bovenste mand (4 l)	D Rooster	F Luchtuitlaat	H Hoofdkabel

- GB
- BG
- DE
- ES
- FR
- GR
- IT
- PT
- NL**
- CA
- SE
- FI
- DK
- NO
- HU
- AR

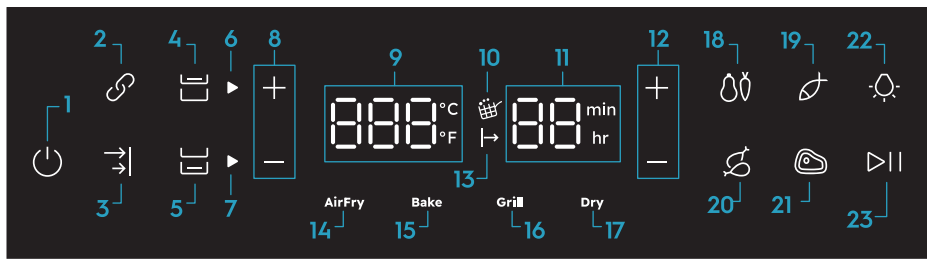

- | | | |
|---|---|--|
| <ul style="list-style-type: none"> 1. Aan/uit 2. Koppelfunctie 3. Synchronisatiefunctie beëindigen 4. Bediening bovenste mand 5. Bediening onderste mand 6. Indicator bovenste mand 7. Indicator onderste mand 8. Temperatuurregelaar | <ul style="list-style-type: none"> 9. Temperatuurindicator (40-200 °C) 10. Schudherinnering 11. Tijdindicator (AirFry: 1-99 min, Dehydrateren: 1-5h) 12. Tijdcontrole 13. Wachten op koken 14. AirFry-functie 15. Bakfunctie 16. Grillfunctie 17. Droogfunctie | <ul style="list-style-type: none"> 18. Groenten 19. Vis 20. Kip 21. Steak 22. Lichtregeling 23. Afspelen/Pauze |
|---|---|--|

Voor het eerste gebruik

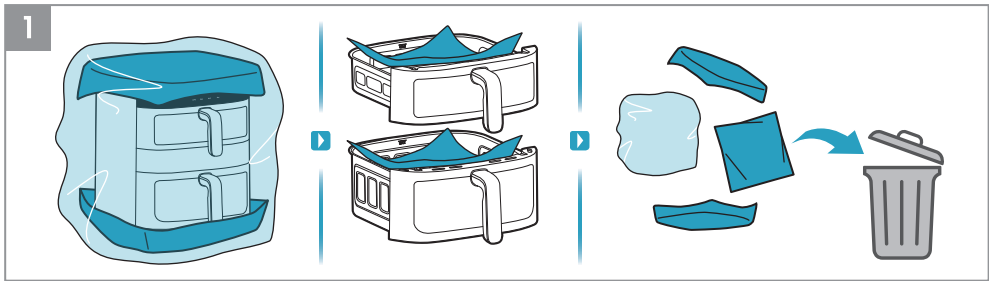

1. Verwijder alle verpakings- en beschermingsmateriaal.

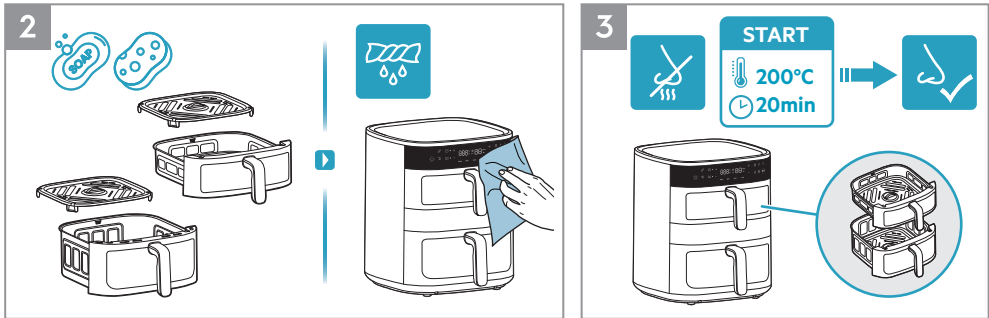

2. Reinig de pan en het rooster met warm water en afwasmiddel. Veeg de binnen- en buitenkant van het apparaat af met een zachte doek.

3. Het is normaal dat een nieuw apparaat de eerste paar keer dat het wordt gebruikt een geur afgeeft. Laat de lege airfryer voor het eerste gebruik 20 minuten op 200 °C draaien om dit te voorkomen.

! Veiligheidsvoorschriften

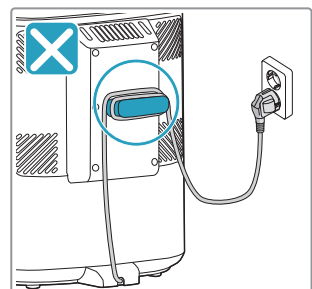
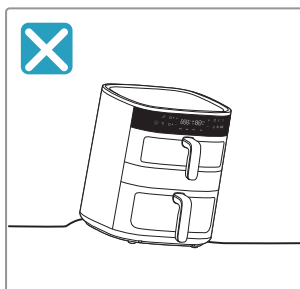
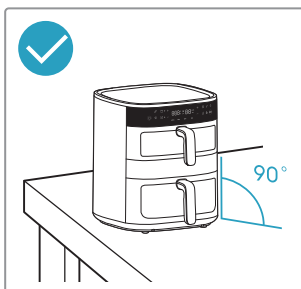
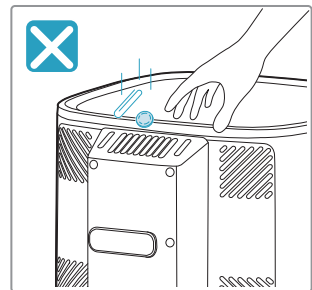
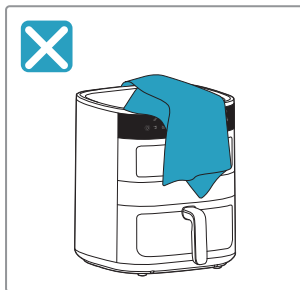
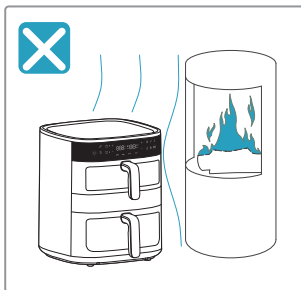

GB

BG

DE

ES

FR

GR

IT

PT

NL

CA

SE

FI

DK

NO







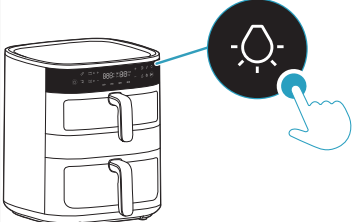
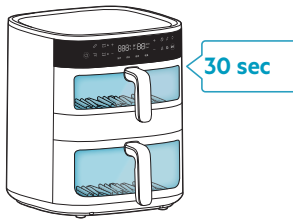
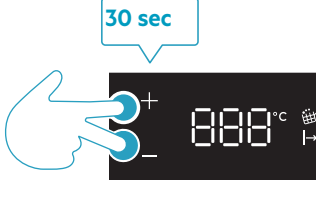
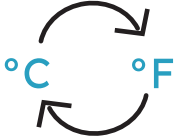







HU

AR

Verlichtingsregeling en temperatuurschaalconversie





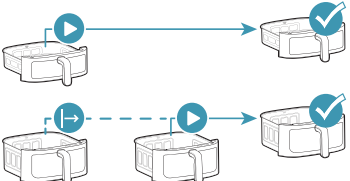









 <p>Verlichtingsregeling</p>		
<p>°C/°F</p> <p>Temperatuurschaalconversie</p>		

Mandselectie

	 <p>4l</p>	 <p>7l</p>	
 <p>Bovenste mand</p>			
 <p>Onderste mand</p>			
 <p>Koppelfunctie</p>			
 <p>Synchronisatiefunctie beëindigen</p>			

GB
BG
DE
ES
FR
GR
IT
PT
NL
CA
SE
FI
DK
NO
HU
AR

Vooraf ingestelde functies

 AirFry					
AirFry	180°C	15min	60~200°C	1-99min	
	170°C	10min	60~200°C	1-99min	
	140°C	15min	60~200°C	1-99min	
	180°C	30min	60~200°C	1-99min	
	200°C	10min	60~200°C	1-99min	
Bake	170°C	15min	60~200°C	1-99min	
Grill	200°C	5min	60~200°C	1-99min	
Dry	80°C	5h	40~80°C	1-5h	

Voor het koken

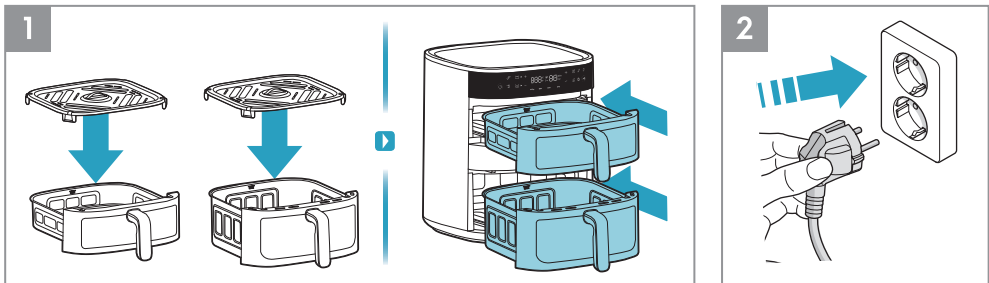

1. Plaats voor elke bereiding het rooster in de mand (het hittebestendige siliconen voetkussen van het rooster hoeft niet te worden verwijderd) en duw de mand volledig in het apparaat.
2. Steek de stekker in het stopcontact.

GB

BG

DE

ES

FR

GR

IT

PT

NL

CA

SE

FI

DK

NO

HU

AR

Gebruiksaanwijzing - Enkele mand

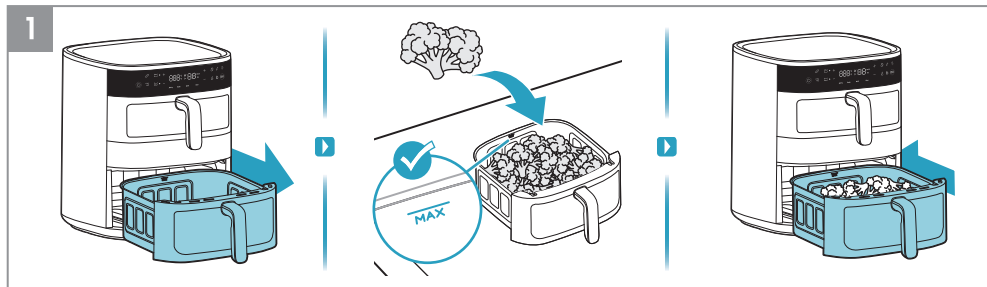

1. Trek één mand naar buiten en plaats de mand op een stabiel oppervlak. Plaats het eten en de mand en houd rekening met de aangegeven maximale capaciteit. Duw vervolgens de mand met eten volledig terug in het apparaat.

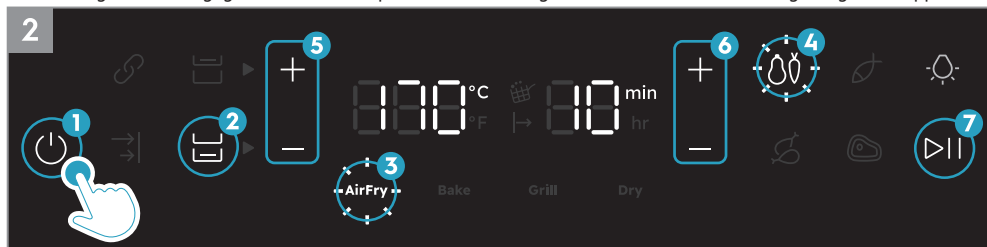

2. Druk de Aan/uit-knop. Selecteer eerst de mand met eten. Selecteer vervolgens de gewenste bereidingswijze, bijvoorbeeld de Air Fry-functie. Pas de tijd en temperatuur aan naar uw smaak of selecteer een van de vooraf ingestelde recepten, bijvoorbeeld Groenten. Druk als laatste op de knop Afspelen/Pauzeren.

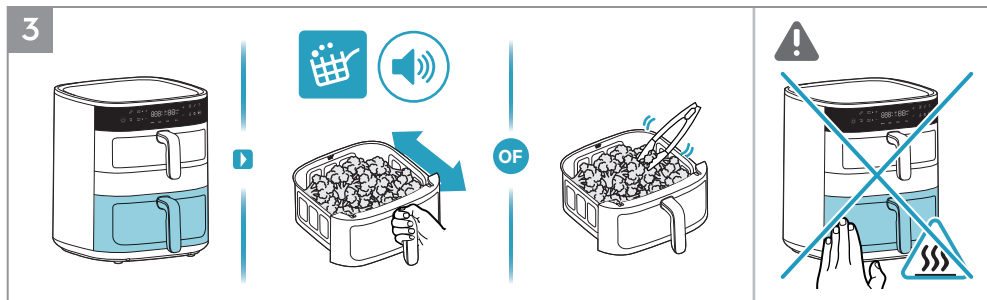

3. Wanneer het pictogram "Schudherinnering" oplicht en er een geluidssignaal klinkt tijdens het bereiden, gebruik dan hittebestendige hulpmiddelen om het eten eenmaal om te draaien of schud het eten voorzichtig in de frituurmand.

⚠ **OPGELET:** Schud de frituurmand niet te hard om te voorkomen dat er eten uit spat en brandwonden veroorzaakt.

⚠ **OPGELET:** Wees voorzichtig met hete oppervlakken wanneer het apparaat in gebruik is.

Schudherinnering

De "Schudherinnering" wordt geactiveerd tijdens de Air Fry-functie en de vooraf ingestelde recepten, zoals groenten, vis, kippenpoten en biefstuk.

Op het moment dat uw eten moet worden geschud of omgedraaid, gaat het pictogram "Schudherinnering" branden en knippert het gedurende één minuut, terwijl er drie keer een pieptoon klinkt.

De "Schudherinnering" is niet verplicht, dus het kookproces gaat gewoon door, zelfs als het eten niet wordt omgedraaid of geschud.

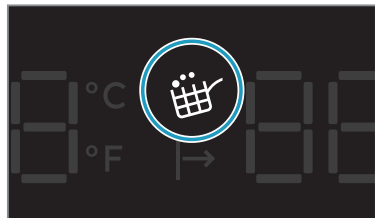



4. Aan het einde van de bereidingstijd geeft het apparaat een piepsignaal. Verwijder de mand voorzichtig en plaats deze op een hittebestendig oppervlak. Haal de stekker na gebruik uit het stopcontact.

⚠ **OPGELET:** Er kan hete stoom uit de mand komen wanneer deze halverwege of aan het einde van het kookproces wordt geopend. Zorg ervoor dat uw gezicht, armen en handen uit de buurt van de stoom blijven wanneer u het opent.

Gebruiksaanwijzing - Bovenste + onderstemand

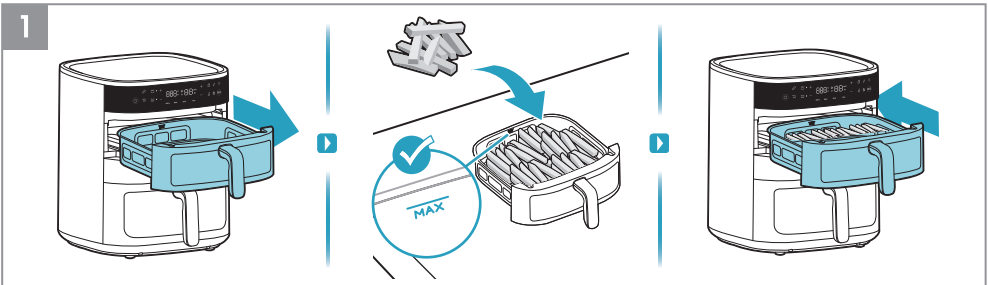

1. Trek eerst de bovenste mand eruit en doe het eten in de mand, bijvoorbeeld frietjes.

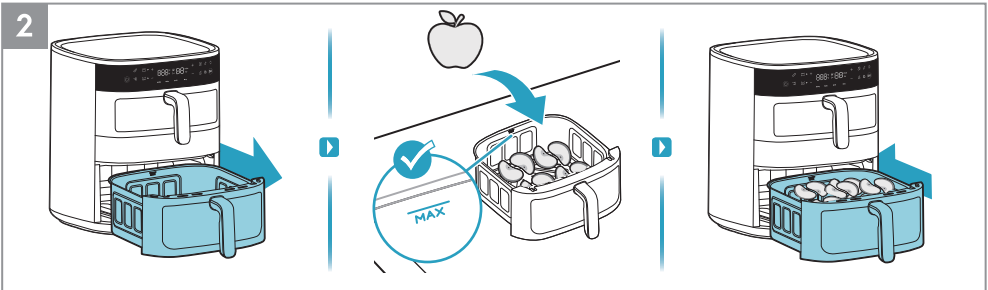

2. Trek vervolgens de onderste mand eruit en doe het eten in de mand, bijvoorbeeld appelschijfjes.



3. Druk de Aan/uit-knop. Selecteer eerst de bovenste mand. Selecteer vervolgens de gewenste bereidingswijze, bijvoorbeeld de Air Fry-functie. Pas de tijd en temperatuur aan naar uw smaak of selecteer een van de vooraf ingestelde recepten, bijvoorbeeld Groenten. Druk als laatste op de knop Afspelen/Pauzeren.

GB

BG

DE

ES

FR

GR

IT

PT

NL

CA

SE

FI

DK

NO

HU

AR

4



4. Selecteer vervolgens de onderste mand. Selecteer vervolgens de gewenste bereidingswijze, bijvoorbeeld de Droogfunctie. Stel de tijd en temperatuur naar wens in. Druk als laatste op de knop Afspelen/Pauzeren.

5

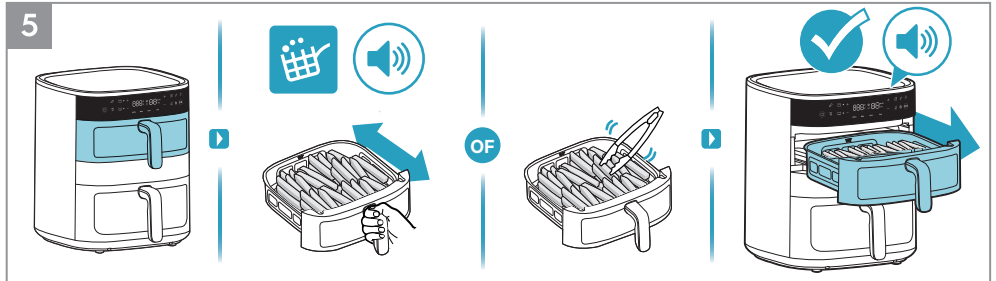

5. Wanneer het pictogram “Schudherinnering” oplicht en er een geluidssignaal klinkt tijdens het bereiden, gebruik dan hittebestendige hulpmiddelen om het eten eenmaal om te draaien of schud het eten voorzichtig in de frituurmand. Aan het einde van de bereidingstijd van de bovenste mand geeft het apparaat een piepsignaal.

6

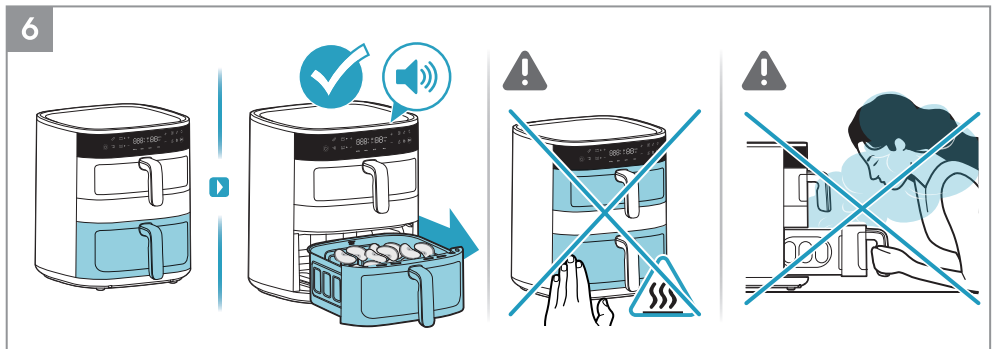

6. Aan het einde van de bereidingstijd van de onderste mand geeft het apparaat een piepsignaal.

7

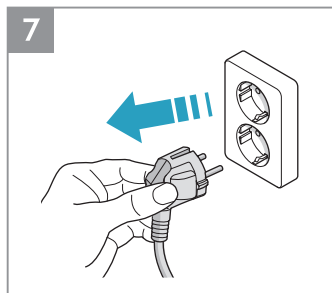

7. Haal de stekker na gebruik uit het stopcontact.

Gebruiksaanwijzing - Koppelfunctie

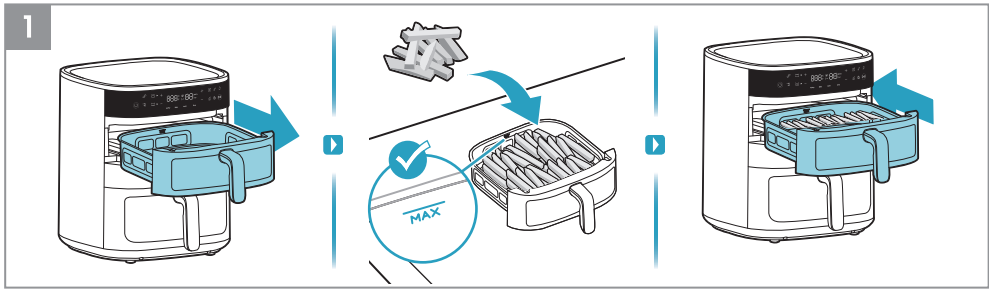

1. Trek eerst de bovenste mand eruit en doe het eten in de mand, bijvoorbeeld frietjes.

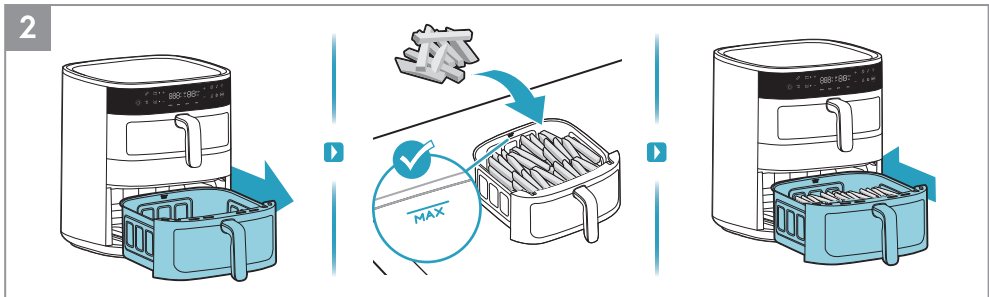

2. Trek vervolgens de onderste mand eruit en doe het eten in de mand, bijvoorbeeld patat.



3. Druk de Aan/uit-knop. Selecteer eerst de koppelfunctie. Selecteer vervolgens de gewenste bereidingswijze, bijvoorbeeld de Air Fry-functie. Pas de tijd en temperatuur aan naar uw smaak of selecteer een van de vooraf ingestelde recepten. Druk als laatste op de knop Afspelen/Pauzeren.

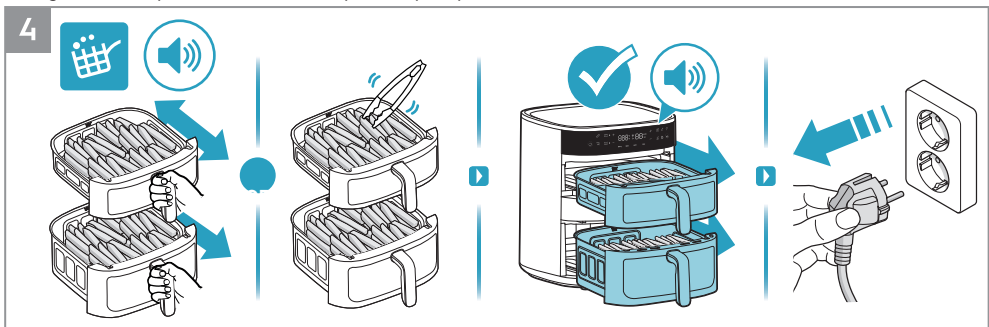

4. Wanneer het pictogram "Schudherinnering" oplicht en er een geluidssignaal klinkt tijdens het bereiden, gebruik dan hittebestendige hulpmiddelen om het eten eenmaal om te draaien of schud het eten voorzichtig in de frituurmand. Aan het einde van de bereidingstijd geeft het apparaat een piepsignaal. Haal de stekker na gebruik uit het stopcontact.

Gebruiksaanwijzing - Synchronisatiefunctie beëindigen

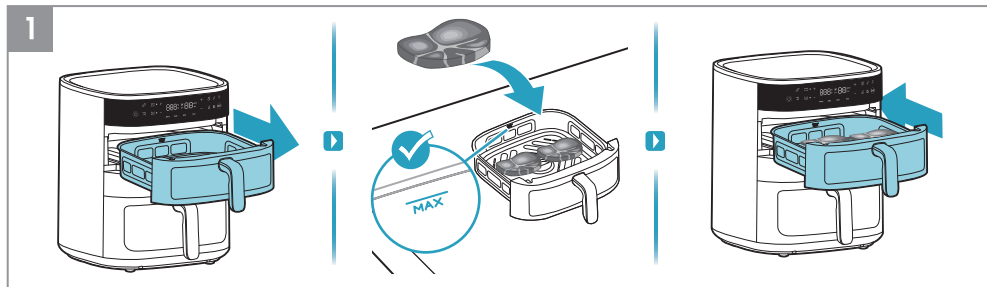

1. Trek eerst de bovenste mand eruit en doe het eten in de mand, bijvoorbeeld steak.

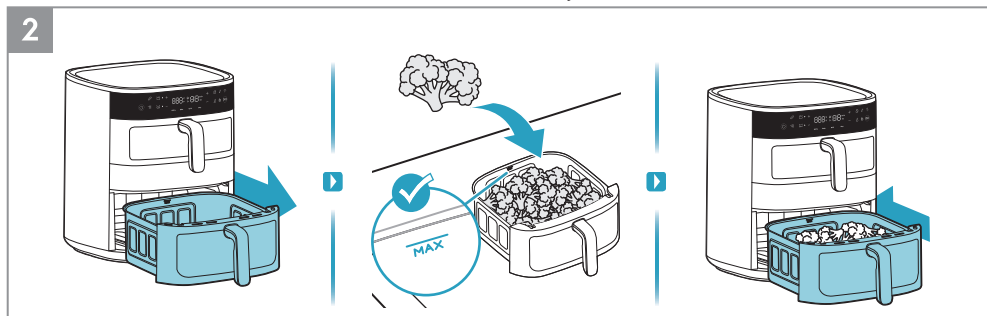

2. Trek vervolgens de onderste mand eruit en doe het eten in de mand, bijvoorbeeld broccoli.



3. Druk de Aan/uit-knop. Selecteer de Synchronisatiefunctie beëindigen. Selecteer eerst de bovenste mand en vervolgens de gewenste bereidingswijze, bijvoorbeeld de Air Fry-functie. Pas de tijd en temperatuur aan naar uw smaak of selecteer een van de vooraf ingestelde recepten, bijvoorbeeld steak.



4. Selecteer vervolgens de onderste mand en kies de gewenste bereidingswijze, bijvoorbeeld de Air Fry-functie. Pas de tijd en temperatuur aan naar uw smaak of selecteer een van de vooraf ingestelde recepten. Druk als laatste op de knop Afspelen/Pauzeren.

GB
BG
DE
ES
FR
GR
IT
PT
NL
CA
SE
FI
DK
NO
HU
AR

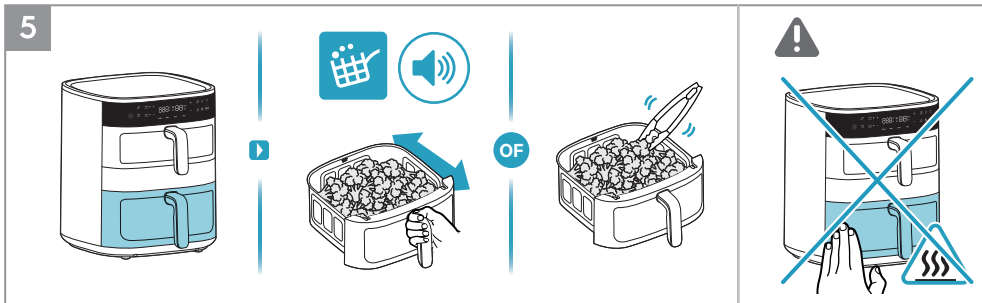

5. Ten eerste wordt de onderste mand met een langere insteltijd voorrang gegeven bij het koken. Wanneer het pictogram “Schudherinnering” oplicht en er een geluidssignaal klinkt tijdens het bereiden, gebruik dan hittebestendige hulpmiddelen om het eten eenmaal om te draaien of schud het eten voorzichtig in de frituurmand.

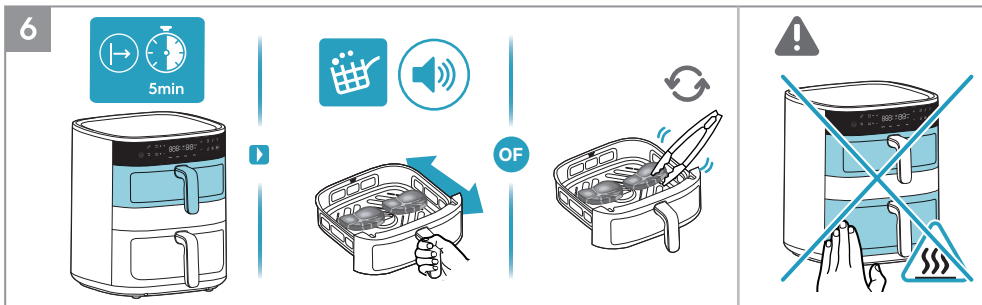

6. Ten tweede begint de bovenste mand met een kortere insteltijd met koken. Wanneer het pictogram “Schudherinnering” oplicht en er een geluidssignaal klinkt tijdens het bereiden, gebruik dan hittebestendige hulpmiddelen om het eten eenmaal om te draaien of schud het eten voorzichtig in de frituurmand.

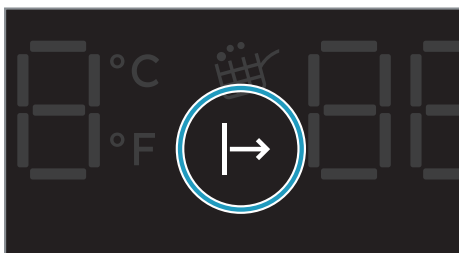

Wachten op kookindicator

Wanneer de functie “Synchronisatiefunctie beëindigen” is geactiveerd, wacht de mand met de kortere bereidingstijd totdat de mand met de langere bereidingstijd een tijdje heeft gekookt, zodat beide manden tegelijkertijd klaar zijn met koken. Tijdens deze fase blijft de “Wachten op kookindicator” branden totdat het koken beëindigt.

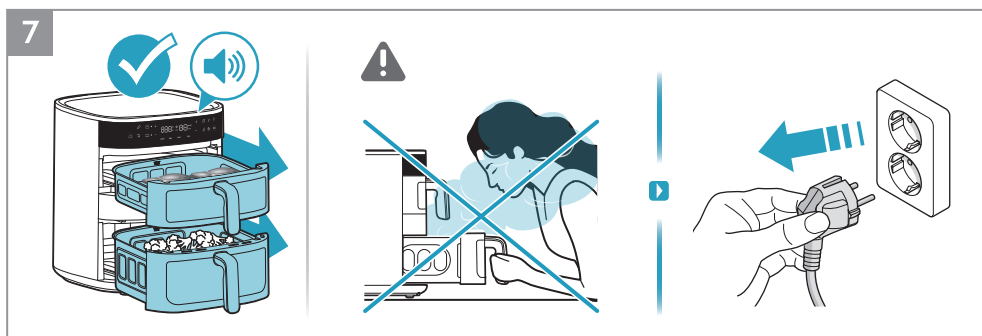

7. Aan het einde van de bereidingstijd geeft het apparaat een piepsignaal. Haal de stekker na gebruik uit het stopcontact.

Reiniging

1

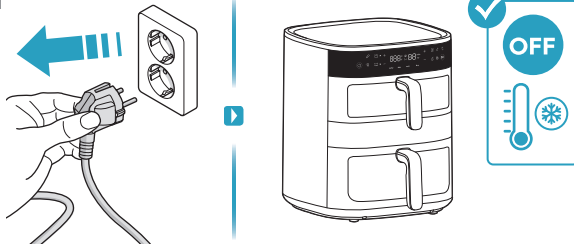

2



1. Haal altijd de stekker uit het stopcontact en wacht tot het apparaat is afgekoeld voordat u het schoonmaakt.
2. Veeg de buitenkant van het apparaat af met een zachte doek.

3

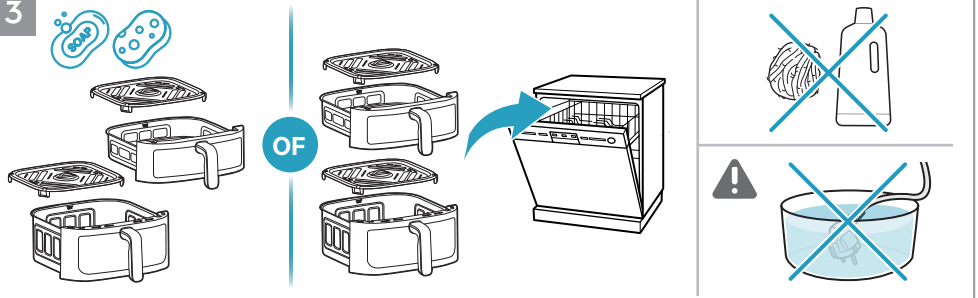

3. Reinig de pan en het rooster met warm water en afwasmiddel, of plaats ze in de vaatwasser.

⚠OPMERKING: Gebruik geen schurende reinigingsmiddelen of metalen gereedschap om de antiaanbaklaag te beschermen.

OPGELET: Dompel het product, het snoer of de stekker nooit onder in water of een andere vloeistof.



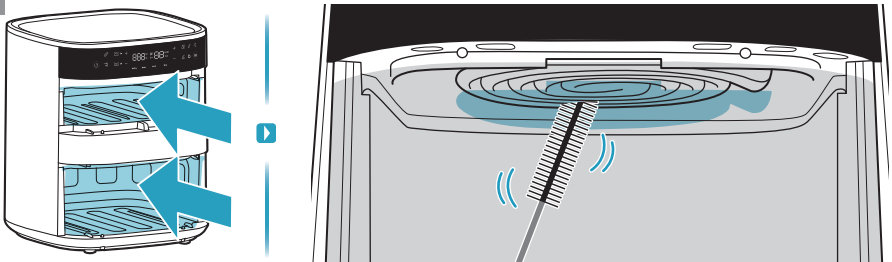

























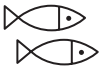









4



























4. Reinig het verwarmingselement met een reinigingsborstel.

OPMERKING: Zorg dat het apparaat volledig is afgekoeld voordat u het verwarmingselement schoonmaakt.

Kookgids

							
AirFry	7mm/10mm 	 4l	400g	180 °C	18min		
		 7l	400g	180 °C	18min		
AirFry		 4l	400g	170 °C	8min		
		 7l	400g	170 °C	10min		
AirFry		 4l	400g/2stuks	140 °C	15min		
		 7l	400g/2stuks	140 °C	15min		
AirFry		 4l	1000g/8stuks	180 °C	28min		
		 7l	1000g/8stuks	180 °C	28min		
AirFry		 4l	400g/2stuks	200 °C	10min		
		 7l	400g/2stuks	200 °C	10min		
AirFry		 4l	220g/15 cm	160 °C	12min		
		 7l	220g/15 cm	160 °C	14min		

- GB
- BG
- DE
- ES
- FR
- GR
- IT
- PT
- NL**
- CA
- SE
- FI
- DK
- NO
- HU
- AR

							
AirFry		 7l	1200g	180 °C	55min		
AirFry		 7l	400g/9stuks	160 °C	20min		
Grill		 4l	180g/4stuks	180 °C	8min		
		 7l	180g/4stuks	180 °C	9min		
Dry		 4l	180g	80 °C	3h		
		 7l	180g	80 °C	3h		
Dry		 4l	200g	80 °C	3h		
		 7l	200g	80 °C	3h		

GB
BG
DE
ES
FR
GR
IT
PT
NL
CA
SE
FI
DK
NO
HU
AR

Wat te doen als...

Probleem	Controleer of...
U het apparaat niet kunt activeren of bedienen.	<ul style="list-style-type: none">• Het apparaat is correct aangesloten op een stroombron.• De manden staan in de juiste positie. Zorg ervoor dat ze volledig in het apparaat zijn gedrukt om de stroomtoevoer mogelijk te maken.• De kooktijd is ingesteld.
U de mand niet in het apparaat kunt schuiven.	<ul style="list-style-type: none">• De mand is boven zijn maximale capaciteit gevuld.• De mand is correct geplaatst. Het moet vastklikken wanneer u het in de eenheid plaatst.• Er ligt een voorwerp onder de mand dat verhindert dat deze goed kan worden gesloten.
Er witte rook uit het apparaat komt.	<ul style="list-style-type: none">• Het eten dat u bereidt is te vet.• De mand, het rooster en het verwarmingselement zijn schoon.
Het display E1 weergeeft	<ul style="list-style-type: none">• Open stroomkring in de bovenste mand.
Het display E2 weergeeft	<ul style="list-style-type: none">• Kortsluiting in de bovenste mand.
Het display E3 weergeeft	<ul style="list-style-type: none">• Open stroomkring in de onderste mand.
Het display E4 weergeeft	<ul style="list-style-type: none">• Kortsluiting in de onderste mand.
Het display E5 weergeeft	<ul style="list-style-type: none">• Communicatiestoring van de besturingsprintplaat.
Het display E6 weergeeft	<ul style="list-style-type: none">• Communicatiestoring van de voedingsprintplaat.

* Als er foutcodes op het display worden weergegeven, moet het apparaat door een Servicecentrum worden gerepareerd.

Technische gegevens

Product	Air Fryer
Model	AAFD11B
Spanning (V~)	220 V ~ 240 V
Vermogen (W)	2700 W
Frequentie (Hz)	50 ~ 60 Hz
Capaciteit	4 l + 7 l

GB

BG

DE

ES

FR

GR

IT

PT

NL

CA

SE

FI

DK

NO

HU

AR



Libre d'instruccions

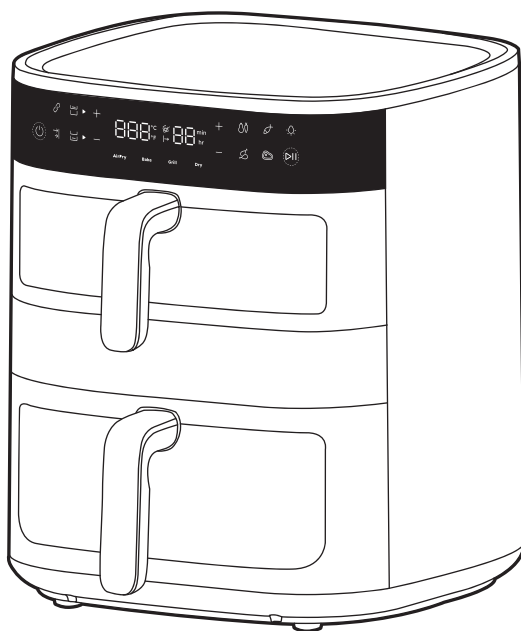

Fregidora d'aire 800 Dual

Vista general

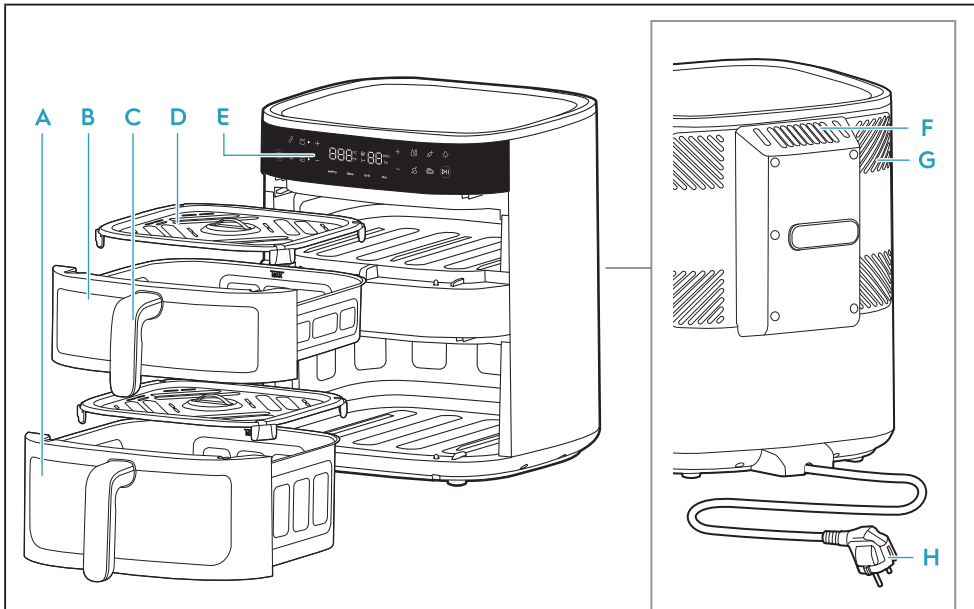

- | | | | |
|---------------------------------------|-------------------------------|----------------------------|----------------------------------|
| A Cistella inferior (7 litres) | C Nansa de la cistella | E Panell de control | G Sistema de refrigeració |
| B Cistella superior (4 litres) | D Reixeta | F Sortida d'aire | H Cable d'alimentació |

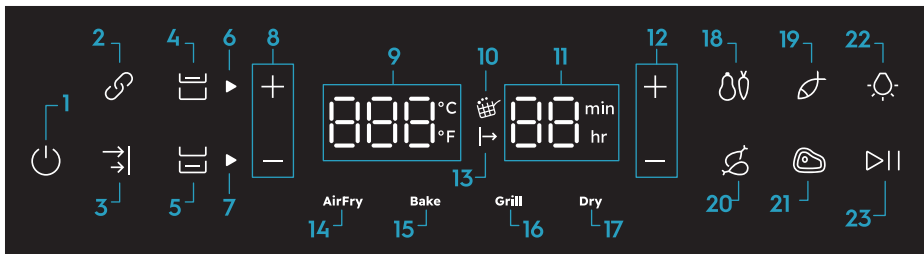

- | | | | |
|---|--|--------------------------------|---------------------|
| 1. Engegar/Apagar | 7. Indicador de la cistella inferior | 12. Control de temps | 21. Filet |
| 2. Funció d'enllaç | 8. Control de temperatura | 13. En espera de cocció | 22. Control de llum |
| 3. Funció de finalització sincronitzada | 9. Indicador de temperatura (40-200 °C) | 14. Funció de fregidora d'aire | 23. Iniciar/Pausar |
| 4. Control de la cistella superior | 10. Recordatori de remenar | 15. Funció de forn | |
| 5. Control de la cistella inferior | 11. Indicador de temps (Fregidora d'aire: 1-99 minuts, Deshidratar: 1-5 hores) | 16. Funció de graella | |
| 6. Indicador de la cistella superior | | 17. Funció de deshidratació | |
| | | 18. Verdures | |
| | | 19. Peix | |
| | | 20. Pollastre | |

Abans del primer ús

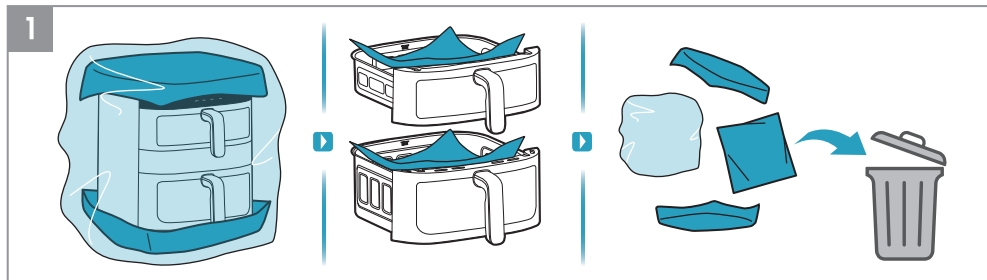

1. Retireu tot l'embalatge i el material protector del producte.

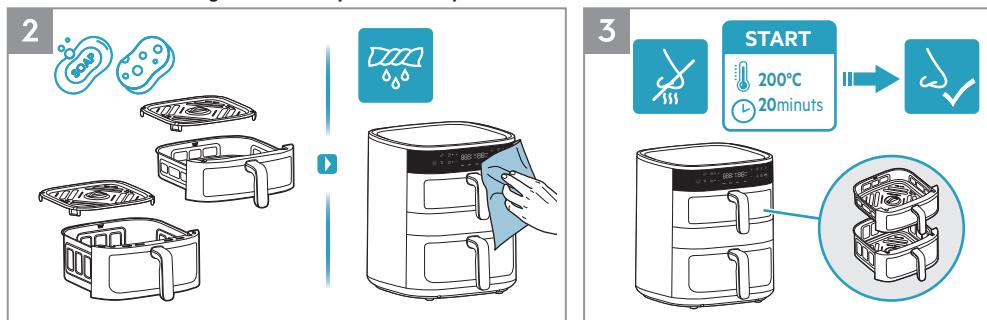

2. Netegeu la safata i la reixeta amb aigua tèbia i detergent per a plats. Netegeu l'interior i l'exterior de l'aparell amb un drap suau.

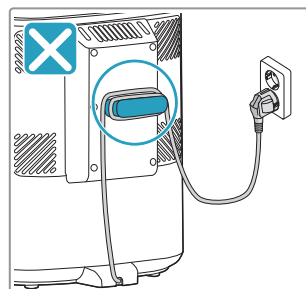
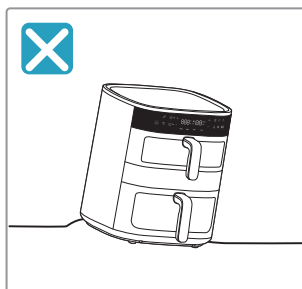
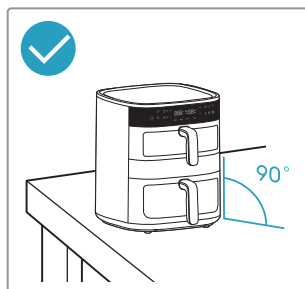
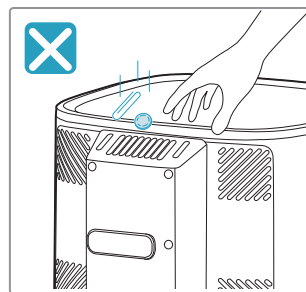
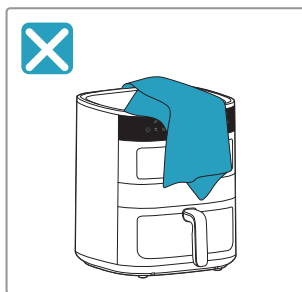
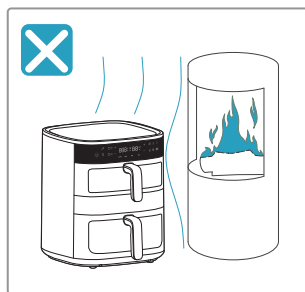

3. És normal que un aparell nou emeti olors les primeres vegades que es faci servir. Comproveu que la fregidora d'aire estigui buida, i deixeu-la a 200 °C durant 20 minuts abans de fer-la servir per primer cop per evitar això.

! Precaucions de seguretat





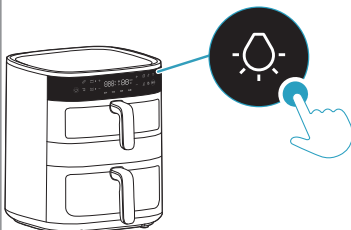
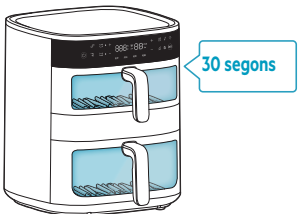

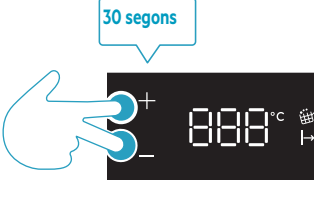
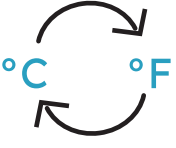



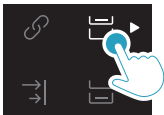





GB
BG
DE
ES
FR
GR
IT
PT
NL
CA
SE
FI
DK
NO
HU
AR

Control de llum i conversió d'escala de temperatura





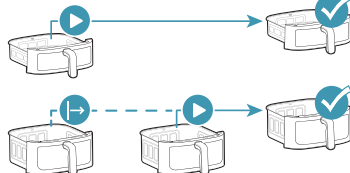









 <p>Control de llum</p>		
 <p>Conversió d'escala de temperatura</p>		

Selecció de cistella

	 <p>4litres</p>	 <p>7litres</p>	
 <p>Cistella superior</p>			
 <p>Cistella inferior</p>			
 <p>Funció d'enllaç</p>			
 <p>Funció de finalització sincronitzada</p>			

- GB
- BG
- DE
- ES
- FR
- GR
- IT
- PT
- NL
- CA**
- SE
- FI
- DK
- NO
- HU
- AR

Funcions predefinides

					
Air Fry	180°C	15 minuts	60-200°C	1-99 minuts	
	170°C	10 minuts	60-200°C	1-99 minuts	
	140°C	15 minuts	60-200°C	1-99 minuts	
	180°C	30 minuts	60-200°C	1-99 minuts	
	200°C	10 minuts	60-200°C	1-99 minuts	
Bake	170°C	15 minuts	60-200°C	1-99 minuts	
Grill	200°C	5 minuts	60-200°C	1-99 minuts	
Dry	80°C	5hores	40-80°C	1-5hores	

GB
BG
DE
ES
FR
GR
IT
PT
NL
CA
SE
FI
DK
NO
HU
AR

Abans de la cocció

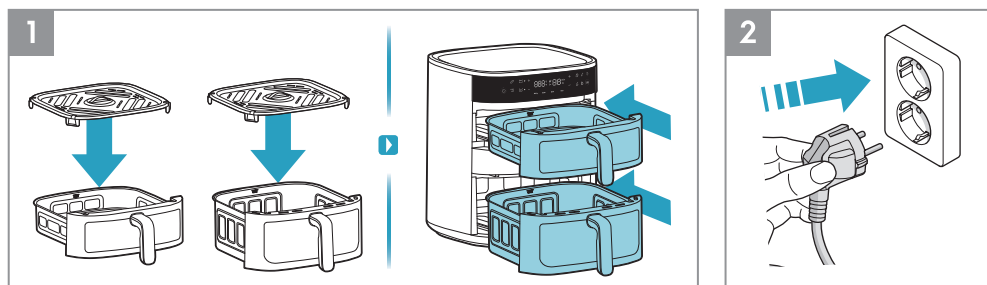

1. Abans de cada cocció, col·loqueu la reixeta dins la cistella (no cal retirar els suports de silicona resistent a la calor de la reixeta) i introduïu la cistella dins l'aparell.
2. Connecteu l'endoll a la presa de corrent.

Mètode d'utilització - Cistella única

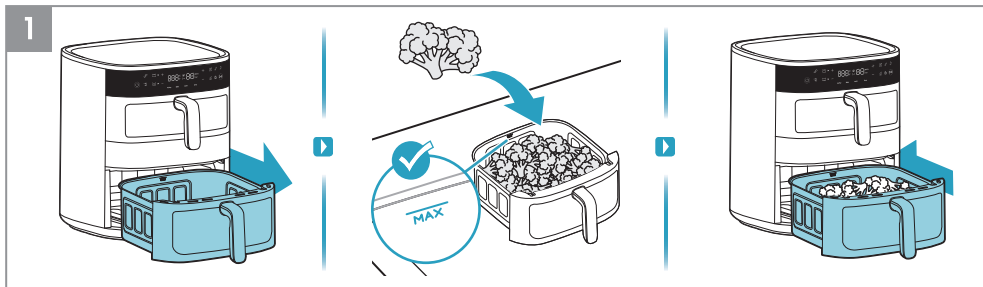

1. Traieu una cistella i col·loqueu-la sobre una superfície estable; poseu-hi els aliments respectant la indicació de capacitat «MAX». A continuació, introduïu completament la cistella amb els aliments a l'aparell.



2. Premeu el botó d'Engregar/Apagar. Primer seleccioneu la cistella amb els aliments. Després seleccioneu el mètode de cocció desitjat, per exemple la funció de fregidora d'aire. Ajusteu el temps i la temperatura al vostre gust o seleccioneu una de les receptes predefinides, per exemple Verdures. Finalment, premeu el botó Iniciar/Pausar.

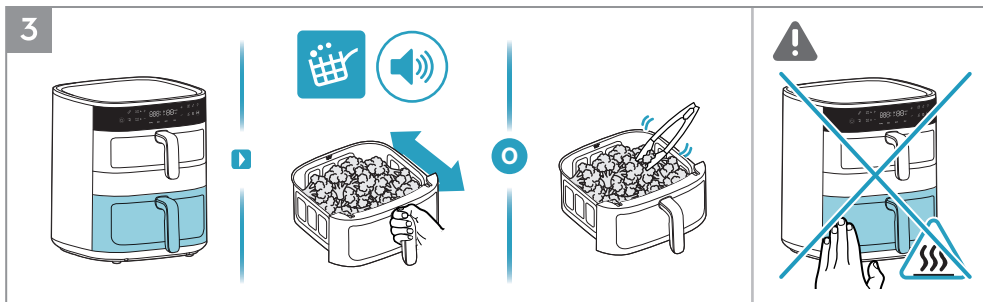

3. Quan la icona «Recordatori de remenar» s'encengui i emeti un senyal acústic durant el procés de cocció, utilitzeu estris resistent a la calor per girar els aliments una vegada o sacsegeu lleugerament els aliments dins la cistella de fregir.

▲ **PRECAUCIÓ:** No sacsegeu la cistella de fregir amb força per evitar esquitxades que puguin causar cremades.

▲ **PRECAUCIÓ:** Aneu amb compte amb les superfícies calentes quan l'aparell estigui en funcionament.

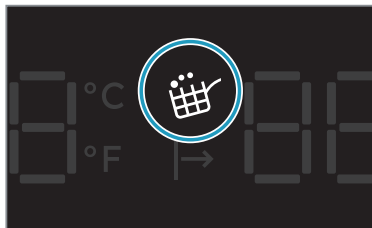

Recordatori de remenar

El «Recordatori de remenar» s'activa durant la funció de fregidora d'aire i en les receptes predefinides, com ara Verdures, Peix, Cuixes de pollastre i Filet.

Quan sigui el moment de remenar o donar la volta als aliments, la icona «Recordatori de remenar» s'encendrà i parpel·larà durant un minut, mentre que el senyal acústic sonarà tres vegades.

El «Recordatori de remenar» no és obligatori; la cocció continuarà amb normalitat encara que no es doni la volta als aliments o no es remenin.

GB

BG

DE

ES

FR

GR

IT

PT

NL

CA

SE

FI

DK

NO

HU

AR

4

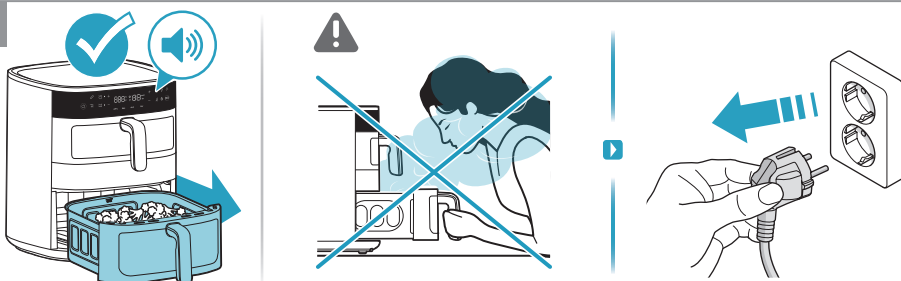

4. Al final del temps de cocció, l'aparell emetrà un senyal acústic. Traieu la cistella amb cura i col·loqueu-la sobre una superfície resistent a la calor. Desendol·leu l'aparell després de fer-lo servir.

⚠ **PRECAUCIÓ:** Pot sortir vapor calent de la cistella quan s'obre durant o al final de la cocció. Assegureu-vos de mantenir la cara, els braços i les mans allunyats del vapor quan obriu l'aparell.

Mètode d'utilització - Cistella superior + inferior

1

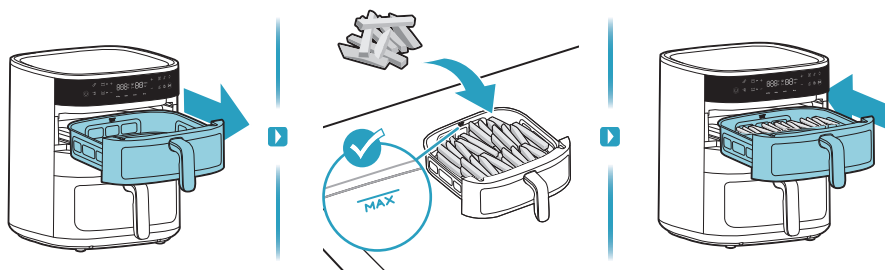

1. Primer, traieu la cistella superior i poseu-hi els aliments, per exemple, patates fregides.

2

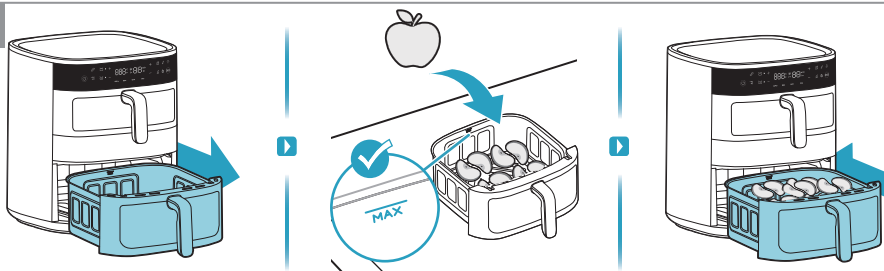

2. Segon, traieu la cistella inferior i poseu-hi els aliments, per exemple rodanxes de poma.

3



3. Premeu el botó d'Engagar/Apagar. Primer seleccioneu la cistella superior. Després seleccioneu el mètode de cocció desitjat, per exemple la funció de fregidora d'aire. Ajusteu el temps i la temperatura al vostre gust o seleccioneu una de les receptes predefinides, per exemple Verdures. Finalment, premeu el botó Iniciar/Pausar.



4. Seguidament, seleccioneu la cistella inferior. Després seleccioneu el mètode de cocció desitjat, per exemple la funció de deshidratació. Ajusteu el temps i la temperatura al vostre gust. Finalment, premeu el botó Iniciar/Pausar.

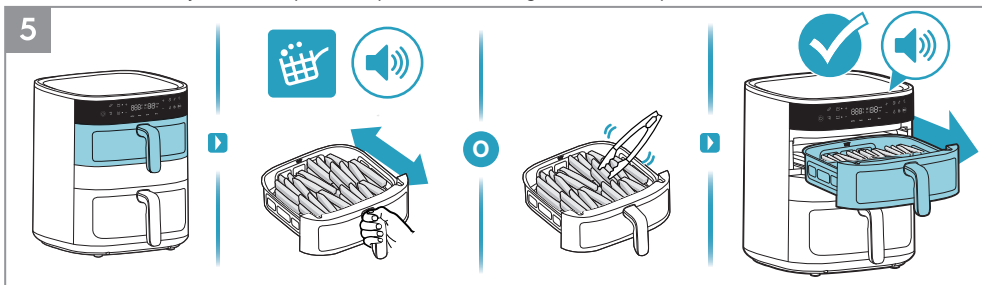

5. Quan la icona «Recordatori de remenar» s'encengui i emeti un senyal acústic durant el procés de cocció, utilitzeu estris resistent a la calor per girar els aliments una vegada o sacsegeu lleugerament els aliments dins la cistella de fregir. Al final del temps de cocció de la cistella superior, l'aparell emetrà un senyal acústic.

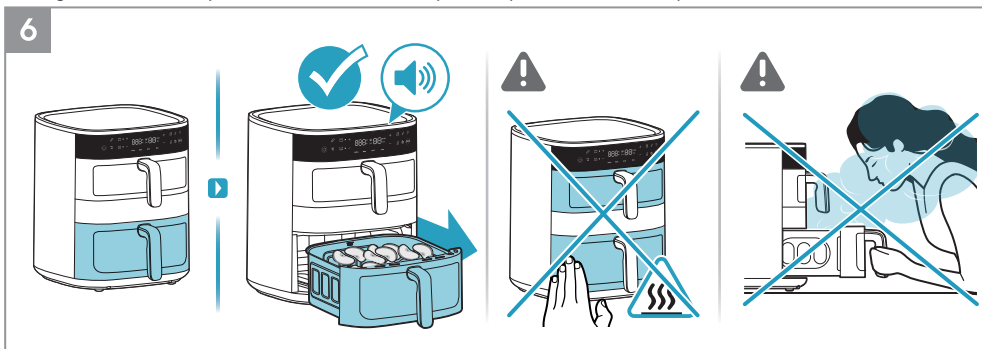

6. Al final del temps de cocció de la cistella inferior, l'aparell emetrà un senyal acústic.

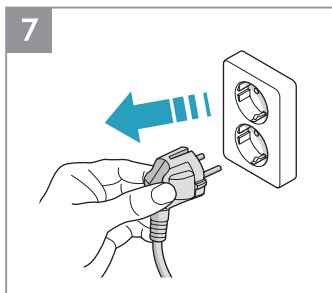

7. Desendolieu l'aparell després de fer-lo servir.

GB
BG
DE
ES
FR
GR
IT
PT
NL
CA
SE
FI
DK
NO
HU
AR

Mètode d'utilització – Funció d'enllaç

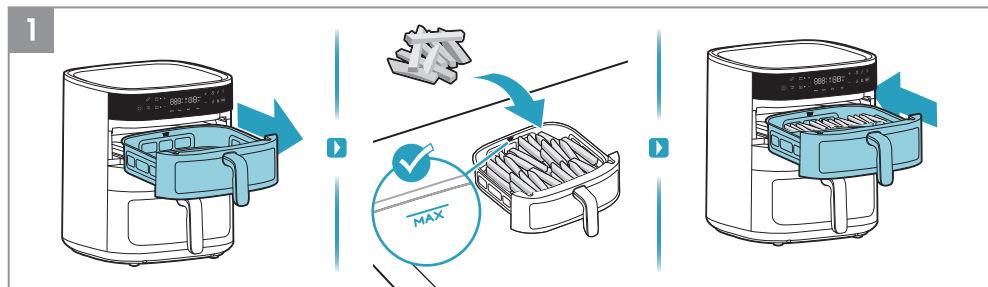

1. Primer, traieu la cistella superior i poseu-hi els aliments, per exemple, patates fregides.

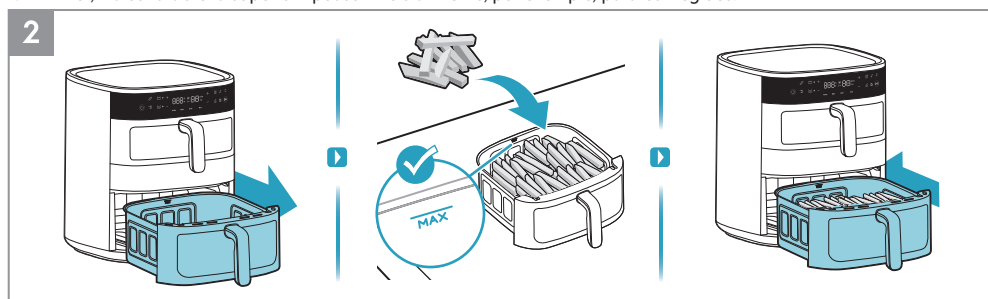

2. A continuació, traieu la cistella inferior i poseu-hi els aliments, per exemple patates fregides.



3. Premeu el botó d'Engegar/Apagar. Primer seleccioneu la funció d'enllaç. Després seleccioneu el mètode de cocció desitjat, per exemple la funció de fregidora d'aire. Ajusteu el temps i la temperatura al vostre gust o seleccioneu una de les receptes predefinides. Finalment, premeu el botó Iniciar/Pausar.

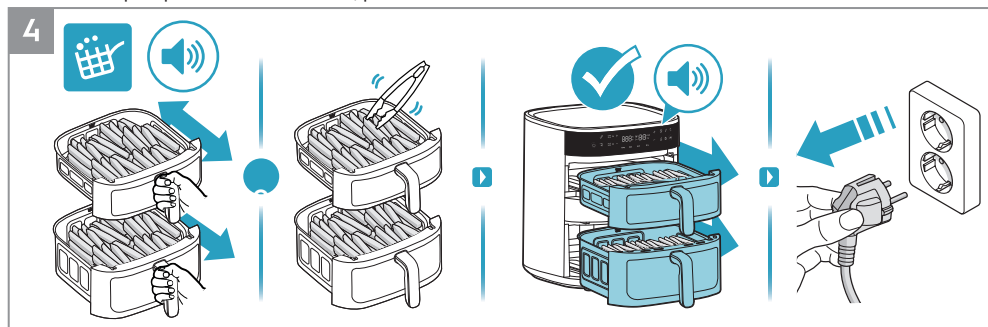

4. Quan la icona «Recordatori de remenar» s'encengui i emeti un senyal acústic durant el procés de cocció, utilitzeu estris resistents a la calor per girar els aliments una vegada o sacsegeu lleugerament els aliments dins la cistella de fregir. Al final del temps de cocció, l'aparell emetrà un senyal acústic. Desendlleu l'aparell després de fer-lo servir.

Mètode d'utilització - Funció de finalització sincronitzada

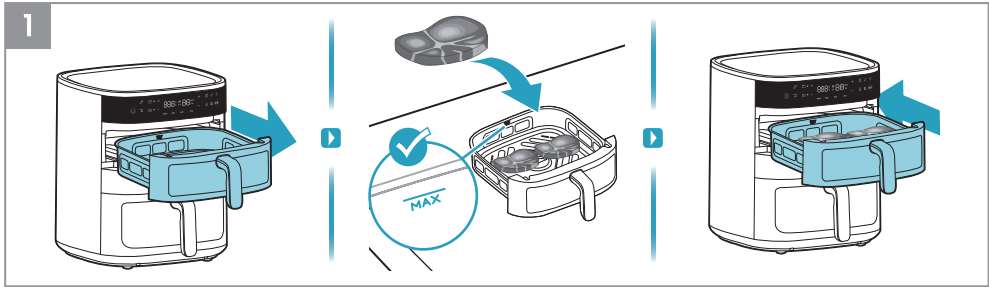

1. Primer, traieu la cistella superior i poseu-hi els aliments, per exemple filet.

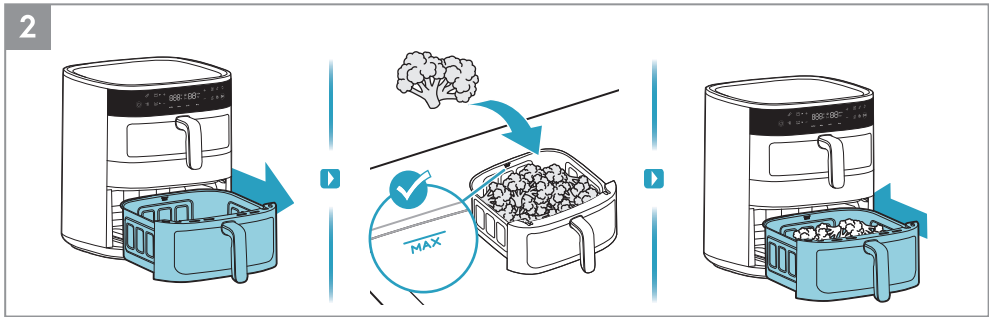

2. Segon, traieu la cistella inferior i poseu-hi els aliments, per exemple bròcoli.



3. Premeu el botó d'Engagar/Apagar. Seleccioneu la funció de finalització sincronitzada. Primer seleccioneu la cistella superior i després el mètode de cocció desitjat, per exemple la funció de fregidora d'aire. Ajusteu el temps i la temperatura al vostre gust o seleccioneu una de les receptes predefinides, per exemple Filet.

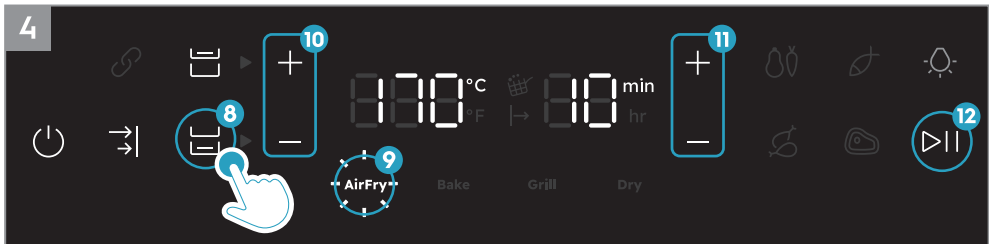

4. Després seleccioneu la cistella inferior i el mètode de cocció desitjat, per exemple la funció de fregidora d'aire. Ajusteu el temps i la temperatura al vostre gust o seleccioneu una de les receptes predefinides. Finalment, premeu el botó Iniciar/Pausar.

GB

BG

DE

ES

FR

GR

IT

PT

NL

CA

SE

FI

DK

NO

HU

AR

5

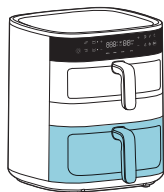

5. Primer, la cistella inferior amb el temps de cocció més llarg tindrà prioritat per començar la cocció. Quan la icona «Recordatori de remenar» s'encengui i emeti un senyal acústic durant el procés de cocció, utilitzeu estris resistent a la calor per girar els aliments una vegada o sacsegeu lleugerament els aliments dins la cistella de fregir.

6

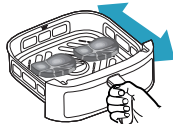
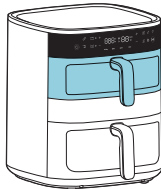

6. A continuació, la cistella superior amb el temps de cocció més curt començarà el procés de cocció. Quan la icona «Recordatori de remenar» s'encengui i emeti un senyal acústic durant el procés de cocció, utilitzeu estris resistent a la calor per girar els aliments una vegada o sacsegeu lleugerament els aliments dins la cistella de fregir.

GB
BG
DE
ES
FR
GR
IT
PT
NL
CA
SE
FI
DK
NO
HU
AR

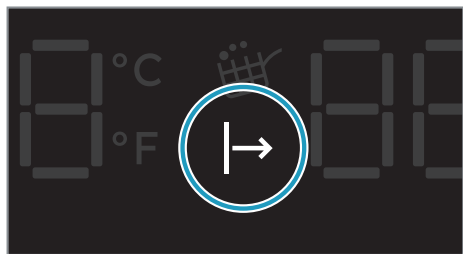

Indicador d'espera de cocció

Quan la «funció de finalització sincronitzada» està activada, la cistella amb el temps de cocció més curt esperarà abans de començar fins que la cistella amb el temps de cocció més llarg hagi estat cuinant durant un temps, de manera que totes dues cistelles acabin la cocció al mateix temps. Durant aquest període, l'«indicador d'espera de cocció» s'encendrà fins que comenci la cocció.

7

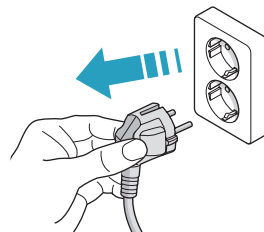
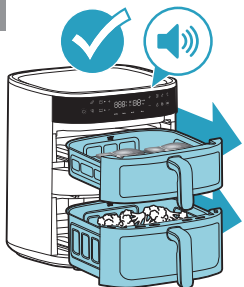

7. Al final del temps de cocció, l'aparell emetrà un senyal acústic. Desendolieu l'aparell després de fer-lo servir.

Neteja

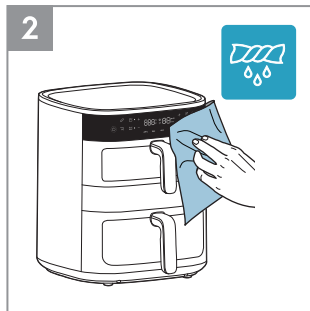
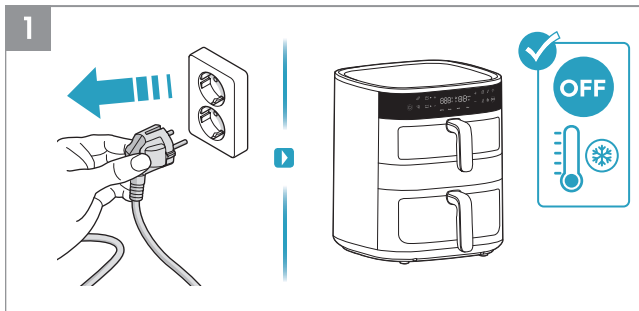

1. Desendolceu sempre l'aparell i espereu que es refredi abans de netejar-lo.
2. Netegeu l'exterior de l'aparell amb un drap suau.

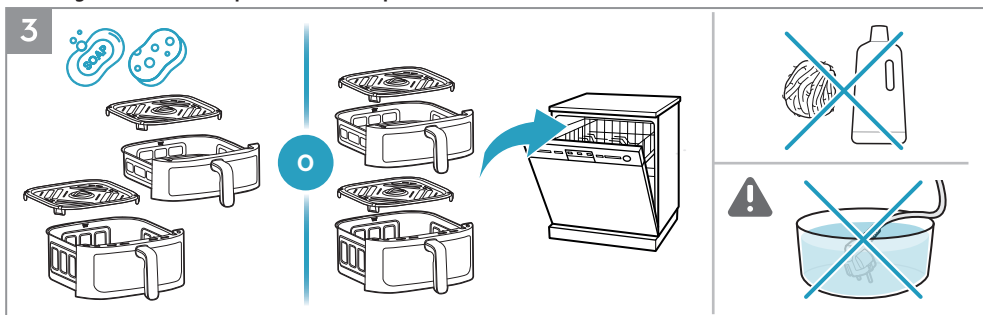

3. Netegeu la safata i la reixeta amb aigua tèbia i detergent per a plats, o poseu-les al rentaplats.

▲NOTA: Eviteu utilitzar productes de neteja abrasius o eines metàl·liques per protegir el recobriments antiadherent.

PRECAUCIÓ: No submergiu mai el producte, el cable ni l'endoll en aigua ni en cap altre líquid.

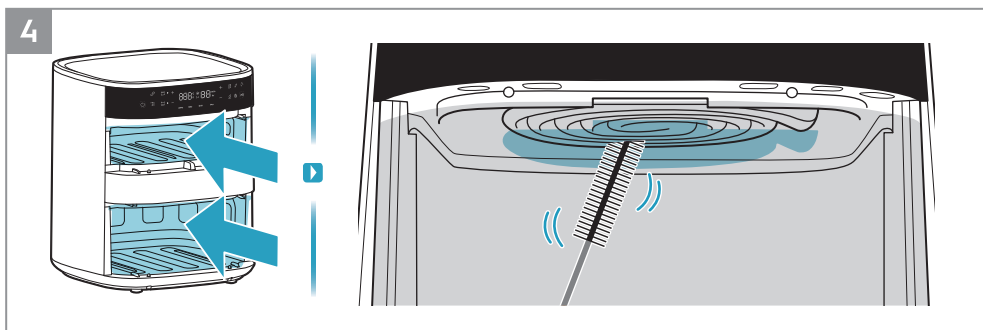





































4. Netegeu l'element calefactor amb un raspall de neteja.













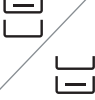











NOTA: Assegureu-vos que l'aparell estigui completament fred abans de netejar l'element calefactor.

GB
BG
DE
ES
FR
GR
IT
PT
NL
CA
SE
FI
DK
NO
HU
AR

Guia de cocció

							
AirFry	7mm/10mm 	 4 litres	400g	180 °C	18min		
		 7 litres	400g	180 °C	18min		
AirFry		 4 litres	400g	170 °C	8min		
		 7 litres	400g	170 °C	10min		
AirFry		 4 litres	400g/2 unitats	140 °C	15min		
		 7 litres	400g/2 unitats	140 °C	15min		
AirFry		 4 litres	1000g/8 unitats	180 °C	28min		
		 7 litres	1000g/8 unitats	180 °C	28min		
AirFry		 4 litres	400g/2 unitats	200 °C	10min		
		 7 litres	400g/2 unitats	200 °C	10min		
AirFry		 4 litres	220g/6 polzades	160 °C	12min		
		 7 litres	220g/6 polzades	160 °C	14min		

GB
BG
DE
ES
FR
GR
IT
PT
NL
CA
SE
FI
DK
NO
HU
AR

							
AirFry		 7litres	1200g	180 °C	55min		
AirFry		 7litres	400g/9 unitats	160 °C	20min		
Grill		 4litres	180g/4 unitats	180 °C	8min		
		 7litres	180g/4 unitats	180 °C	9min		
Dry		 4litres	180g	80 °C	3h		
		 7litres	180g	80 °C	3h		
Dry		 4litres	200g	80 °C	3h		
		 7litres	200g	80 °C	3h		

- GB
- BG
- DE
- ES
- FR
- GR
- IT
- PT
- NL
- CA
- SE
- FI
- DK
- NO
- HU
- AR

Què fer si...

Problema	Comproveu si...
No podeu activar ni fer servir l'aparell.	<ul style="list-style-type: none"> • L'aparell està correctament connectat al subministrament elèctric. • Les cistelles estan en la posició correcta. Comproveu que estiguin ben introduïdes dins l'aparell per permetre el subministrament elèctric. • El temps de cocció està configurat.
No podeu introduir la cistella dins l'aparell.	<ul style="list-style-type: none"> • La cistella està més plena del que hauria d'estar-ho segons la seva capacitat màxima. • La cistella està col·locada correctament. Ha de fer clic quan la col·loqueu dins la unitat. • Hi ha un objecte sota la cistella que impedeix tancar-la correctament.
Surt fum blanc de l'aparell.	<ul style="list-style-type: none"> • Esteu preparant un menjar amb massa greix. • La cistella, la reixeta i l'element calefactor estiguin nets.
La pantalla mostra E1	<ul style="list-style-type: none"> • Circuit obert de la cistella superior.
La pantalla mostra E2	<ul style="list-style-type: none"> • Circuit curt de la cistella superior.
La pantalla mostra E3	<ul style="list-style-type: none"> • Circuit obert de la cistella inferior.
La pantalla mostra E4	<ul style="list-style-type: none"> • Circuit curt de la cistella inferior.
La pantalla mostra E5	<ul style="list-style-type: none"> • Error de comunicació del PCBA de control.
La pantalla mostra E6	<ul style="list-style-type: none"> • Error de comunicació del PCBA d'alimentació.

* En cas que la pantalla mostri codis d'error, l'aparell ha de ser reparat per un centre de servei.

Dades tècniques

Producte	Fregidora d'aire
Model	AAFD11B
Tensió (V~)	220 V ~ 240 V
Potència (W)	2700 W
Freqüència (Hz)	50 ~ 60 Hz
Capacitat	4 L + 7 L



Instruktionsbok

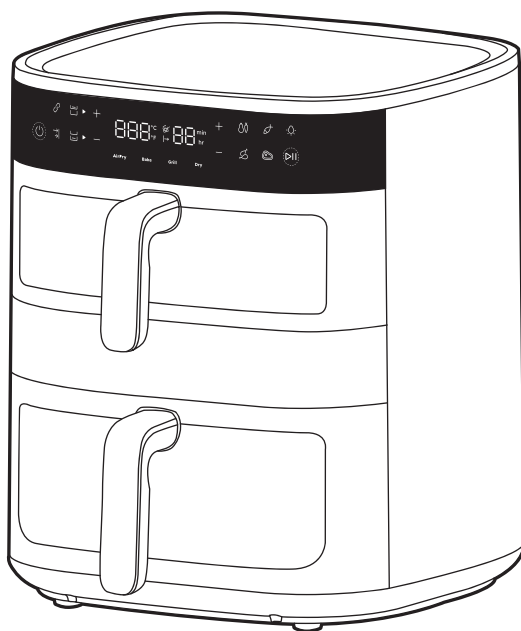

800 Dubbel Varmluftsfritös

Allmän Översikt

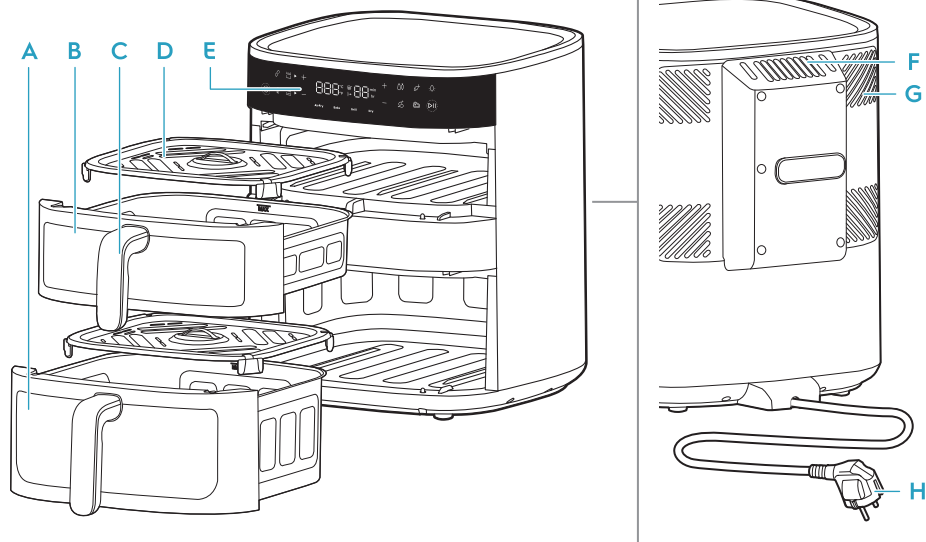

- | | | | |
|--------------------------|----------------------|------------------------|---------------------|
| A Nedre korg (7L) | C Korghandtag | E Kontrollpanel | G Kylsystem |
| B Övre korg (4L) | D Galler | F Luftutlopp | H Huvudsladd |

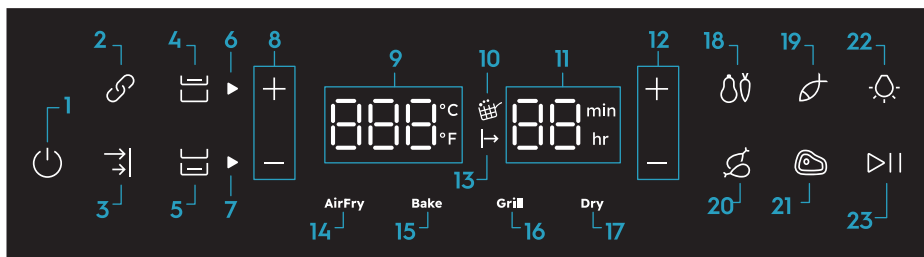

- | | | | |
|-----------------------------------|---|--------------------------|------------------|
| 1. På/Av | 8. Temperaturreglage | 13. Väntar på tillagning | 20. Kyckling |
| 2. Länkfunktion | 9. Temperaturindikator (40-200 °C) | 14. AirFry-funktion | 21. Stek |
| 3. Funktioner Synchroniserat Slut | 10. Skakningspåminnelse | 15. Bakfunktion | 22. Ljusstyrning |
| 4. Kontroll övre korg | 11. Tidsindikator (AirFry: 1-99 min, Dehydrera: 1-5h) | 16. Grillfunktion | 23. Start/Paus |
| 5. Kontroll nedre korg | 12. Tidsreglage | 17. Torkfunktion | |
| 6. Indikator övre korg | | 18. Grönsaker | |
| 7. Indikator nedre korg | | 19. Fisk | |

Innan första användning

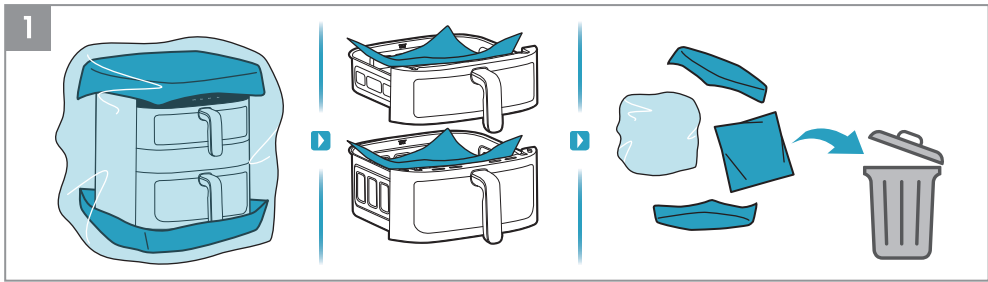

1. Ta bort alla förpackningar och skyddsmaterial.

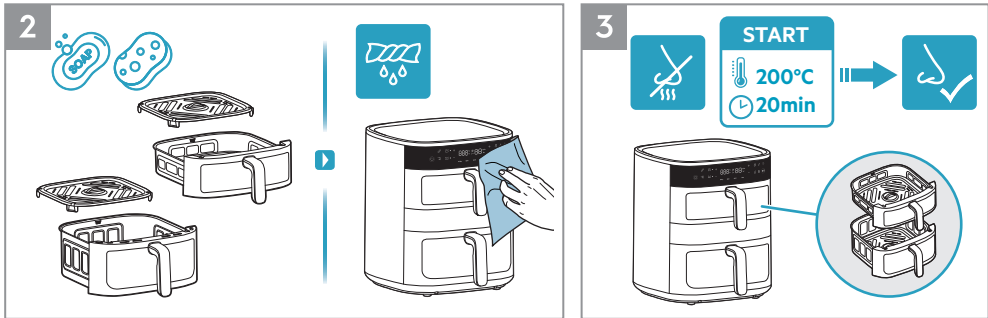

2. Rengör pannan och gallret med varmt vatten och diskmedel. Torka av insidan och utsidan av apparaten med en mjuk trasa.

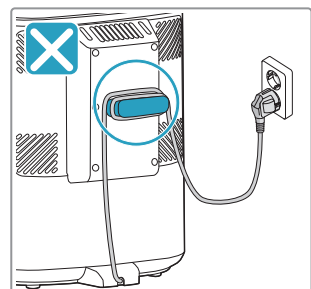
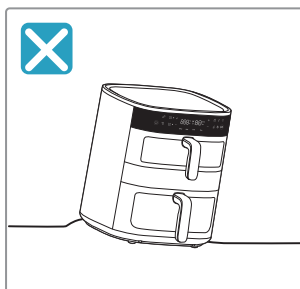
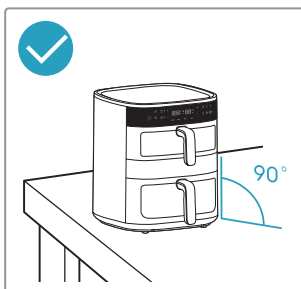
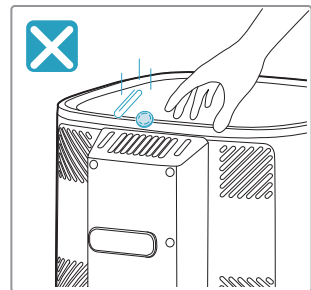
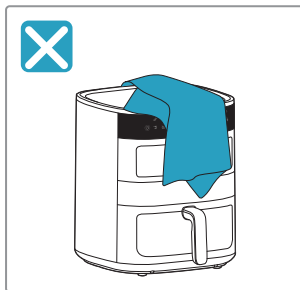
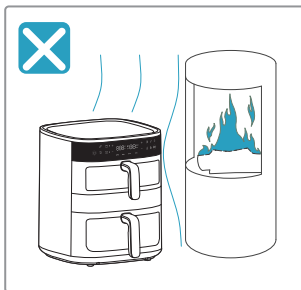

3. Det är normalt att en ny enhet avger lukt de första gångerna den används. Kör den tomma varmluftsfritysen på 200 °C i 20 minuter före första användning för att undvika det.

! Säkerhetsföreskrifter





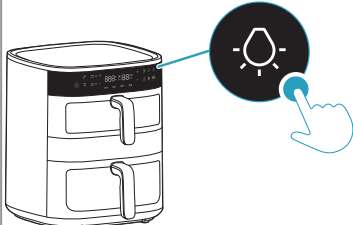
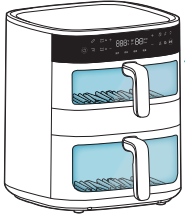

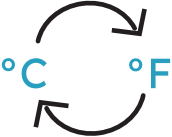









GB
BG
DE
ES
FR
GR
IT
PT
NL
CA
SE
FI
DK
NO
HU
AR

Ljusstyrning & omvandling av temperaturskala





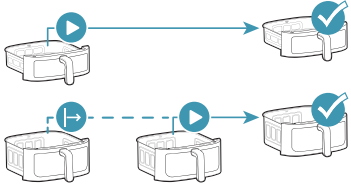









 <p>Ljusstyrning</p>		 <p>30 sek.</p>
<p>°C/°F</p> <p>Omvandling av temperaturskala</p>	 <p>30 sek.</p>	

Val av korg

	 <p>4L</p>	 <p>7L</p>	
 <p>Övre Korg</p>			
 <p>Nedre Korg</p>			
 <p>Länkfunktion</p>			
 <p>Funktion för Synkroniserat Slut</p>			

GB
BG
DE
ES
FR
GR
IT
PT
NL
CA
SE
FI
DK
NO
HU
AR

Förinställda Funktioner

 Air Fry					
Air Fry	180°C	15min	60~200°C	1~99min	
	170°C	10min	60~200°C	1~99min	
	140°C	15min	60~200°C	1~99min	
	180°C	30min	60~200°C	1~99min	
	200°C	10min	60~200°C	1~99min	
Bake	170°C	15min	60~200°C	1~99min	
Grill	200°C	5min	60~200°C	1~99min	
Dry	80°C	5tim	40~80°C	1~5tim	

GB

BG

DE

ES

FR

GR

IT

PT

NL

CA

SE

FI

DK

NO

HU

AR

Innan tillagning

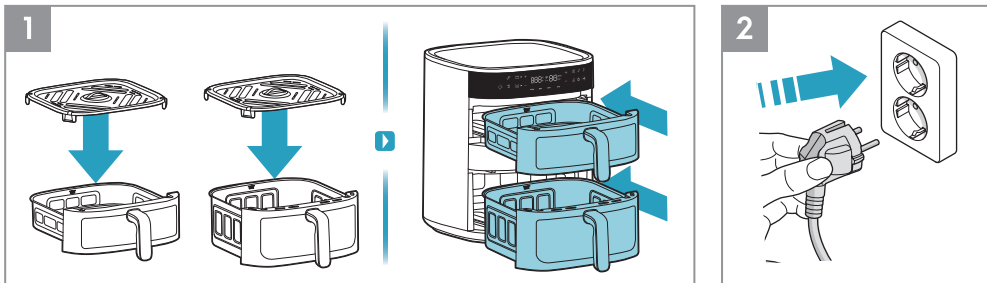

1. Före varje tillagning placerar du gallret i korgen (den värmebeständiga silikonfotplattan på gallret behöver inte tas bort) och tryck in korgen helt i apparaten.
2. Sätt i strömkontakten i vägguttaget.

Användning - En korg

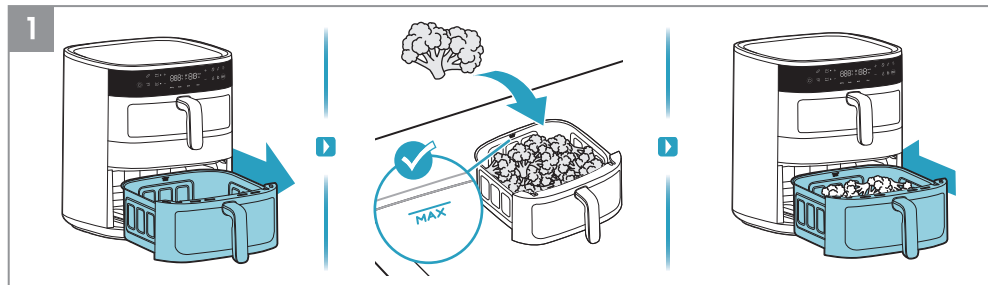

1. Dra ut en korg och placera den på ett stabilt underlag, lägg maten i korgen och ta kapacitetsmarkeringen "MAX." i beaktande. Tryck sedan helt tillbaka korgen med mat in i apparaten.



2. Tryck på På/Av-knappen. Välj först korgen med mat. Välj sedan önskad matlagningsmetod, till exempel Air Fry-funktion. Justera tid och temperatur efter smak eller välj ett av de förinställda recepten, till exempel Grönsak. Tryck till sist på knappen Start/Paus.

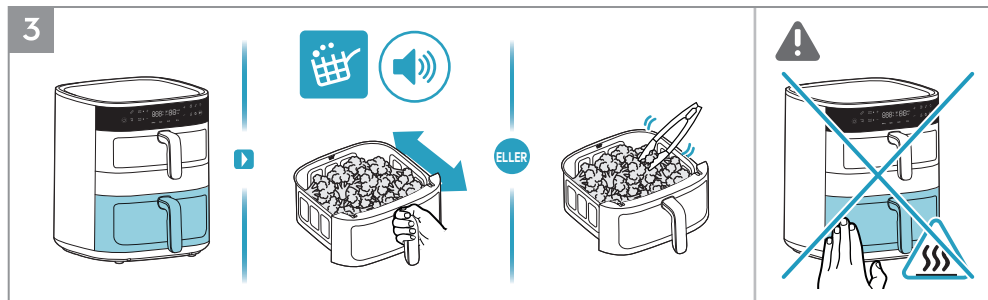

3. När ikonen "Skakningspåminnelse" tänds och piper under tillagningsprocessen använder du värmebeständiga verktyg för att vända maten en gång eller skaka maten försiktigt i stekorkorgen lite.

⚠ **FÖRSIKTIGHET:** Skaka inte stekorkorgen kraftigt för att undvika matstänk och brännskador.

⚠ **FÖRSIKTIGHET:** Var försiktig med heta ytor när apparaten används.

Skakningspåminnelse

"Skakningspåminnelse" aktiveras vid Air Fry-funktionen och för de förinställda recepten, såsom Grönsaker, Fisk, Kycklinglår och Stek.

När det är dags att skaka eller vända på maten tänds ikonen "Skakningspåminnelse" som blinkar i en minut medan ett pipjud upprepas tre gånger.

"Skakningspåminnelsen" är inte obligatorisk, och därför kommer tillagningen att fortsätta som vanligt även om maten inte vänds eller skakas.

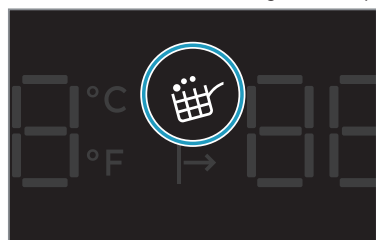



4. I slutet av tillagningstiden kommer apparaten att avge en pipsignal. Ta försiktigt bort korgen och placera den på ett värmebeständigt underlag. Koppla ur apparaten efter användning.

⚠ **FÖRSIKTIGHET:** Varm ånga kan komma ut ur korgen när den öppnas under eller i slutet av tillagningen. Se till att hålla ansikte, armar och händer borta från ångan när du öppnar den.

Användning - Övre + nedre korg

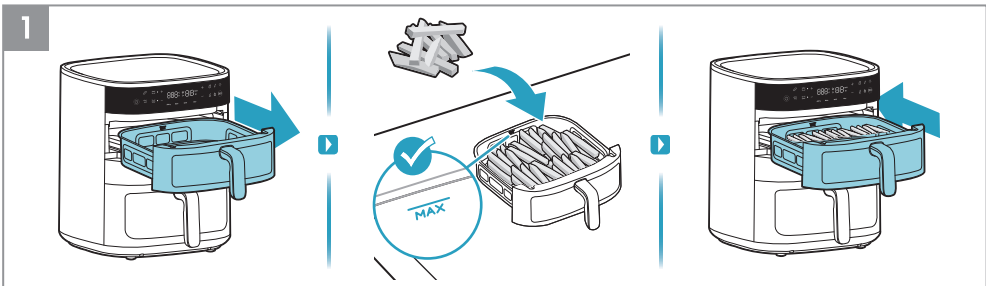

1. Dra först ut den övre korgen och lägg maten i korgen, till exempel pommes frites.

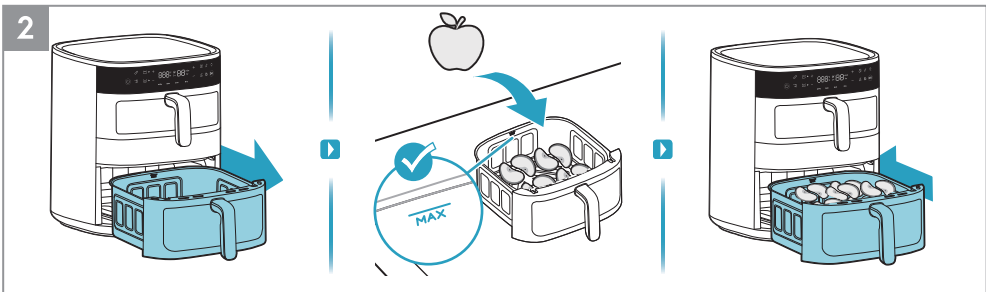

2. Dra sedan ut den nedre korgen och lägg maten i korgen, till exempel äppelskivor.



3. Tryck på På/Av-knappen. Välj först den övre korgen. Välj sedan önskad matlagningsmetod, till exempel Air Fry-funktion. Justera tid och temperatur efter smak eller välj ett av de förinställda recepten, till exempel Grönsak. Tryck till sist på knappen Start/Paus.



4. Välj härnäst den nedre korgen. Välj sedan önskad tillagningsmetod, till exempel Torkfunktion. Justera tid och temperatur efter smak. Tryck till sist på knappen Start/Paus.

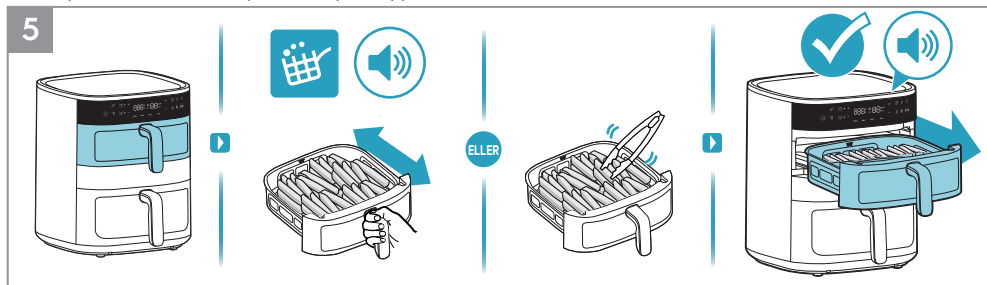

5. När ikonen "Skakningspåminnelse" tänds och piper under tillagningsprocessen använder du värmebeständiga verktyg för att vända maten en gång eller skaka maten försiktigt i stekkorgen lite. I slutet av den övre korgens tillagningstid kommer apparaten att avge en pipsignal.

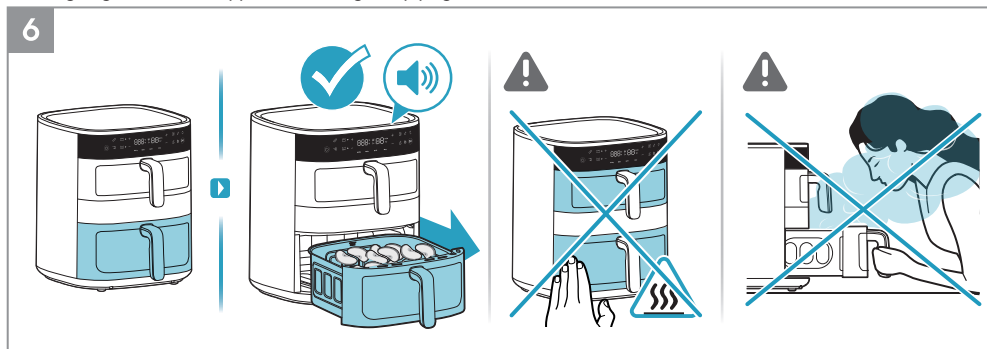

6. I slutet av den nedre korgens tillagningstid kommer apparaten att avge en pipsignal.

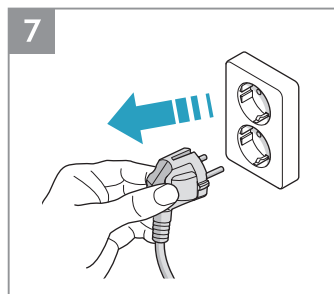

7. Koppla ur apparaten efter användning.

Användning - Länkfunktion

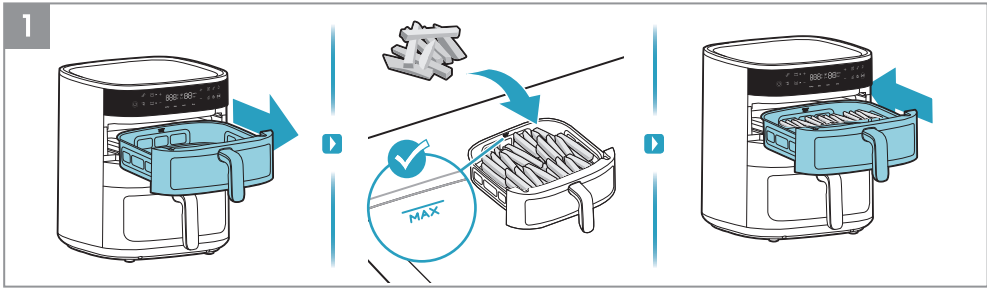

1. Dra först ut den övre korgen och lägg maten i korgen, till exempel pommes frites.

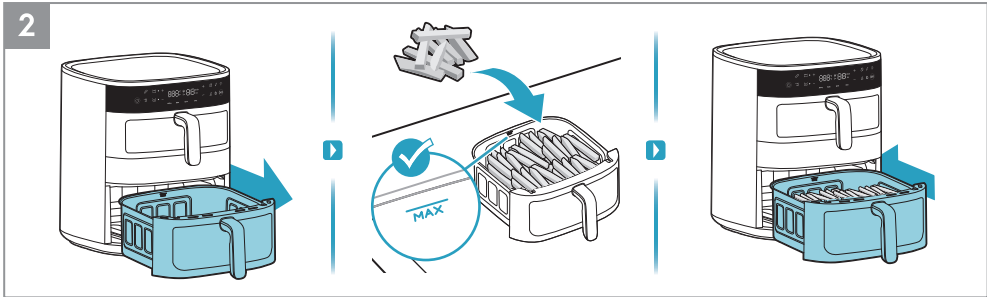

2. Dra sedan ut den nedre korgen och lägg maten i korgen, till exempel pommes frites.



3. Tryck på På/Av-knappen. Välj först länkfunktionen. Välj sedan önskad matlagningsmetod, till exempel Air Fry-funktion. Justera tid och temperatur efter smak eller välj ett av de förinställda recepten. Tryck till sist på knappen Start/Paus.

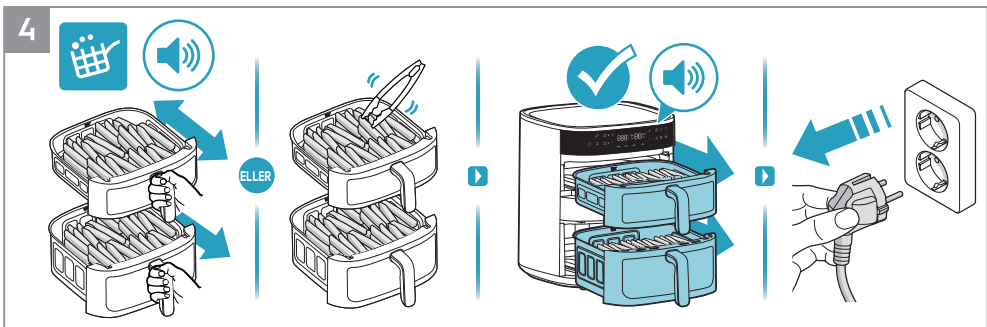

4. När ikonen "Skakningspåminnelse" tänds och piper under tillagningsprocessen använder du värmebeständiga verktyg för att vända maten en gång eller skaka maten försiktigt i stekkorgen lite. I slutet av tillagnings tiden kommer apparaten att avge en pipsignal. Koppla ur apparaten efter användning.

Användning - Funktion för Synkroniserat Slut

1

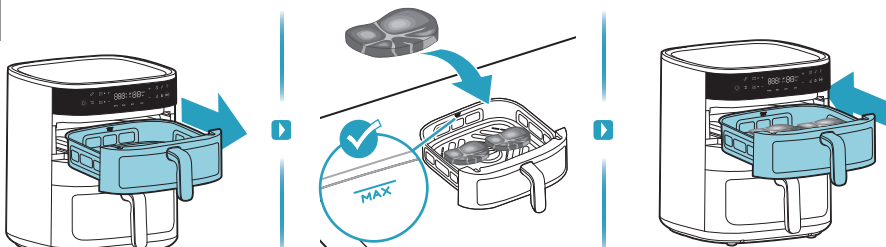

1. Dra först ut den övre korgen och lägg maten i korgen, till exempel en stek.

2

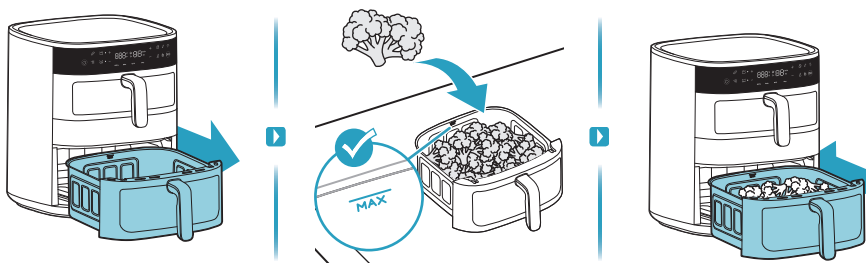

2. Dra sedan ut den nedre korgen och lägg maten i korgen, till exempel broccoli.

3



3. Tryck på På/Av-knappen. Välj funktionen för Synkroniserat Slut. Välj först den övre korgen och välj sedan önskad tillagningsmetod, till exempel Air Fry-funktion. Justera tid och temperatur efter smak eller välj ett av de förinställda recepten, till exempel Stek.

4

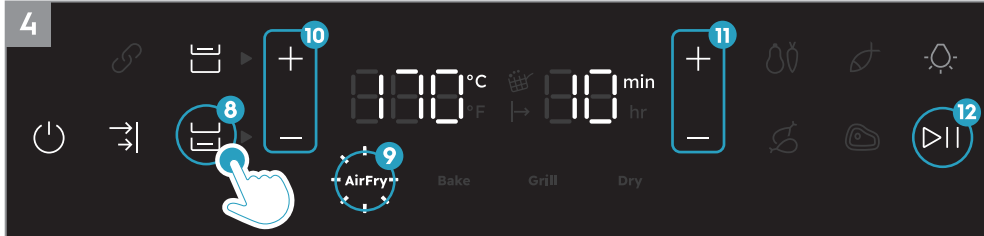

4. Välj sedan den nedre korgen och välj önskad tillagningsmetod, till exempel Air Fry-funktion. Justera tid och temperatur efter smak eller välj ett av de förinställda recepten. Tryck till sist på knappen Start/Paus.

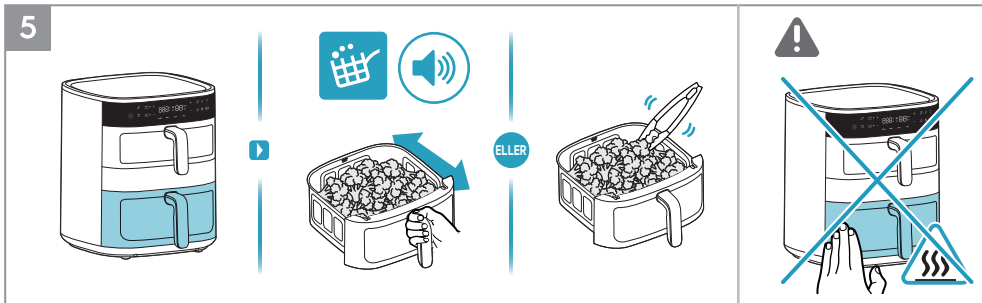

5. Först kommer den nedre korgen med längre inställd tid att prioriteras för tillagning. När ikonen "Skakningspåminnelse" tänds och piper under tillagningsprocessen använder du värmebeständiga verktyg för att vända maten en gång eller skaka maten försiktigt i stekkorgen lite.

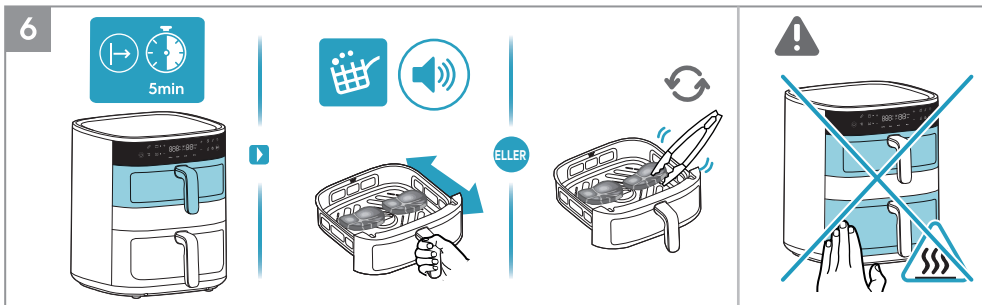

6. Sedan kommer den övre korgen med kortare inställd tid att påbörja tillagning. När ikonen "Skakningspåminnelse" tänds och piper under tillagningsprocessen använder du värmebeständiga verktyg för att vända maten en gång eller skaka maten försiktigt i stekkorgen lite.

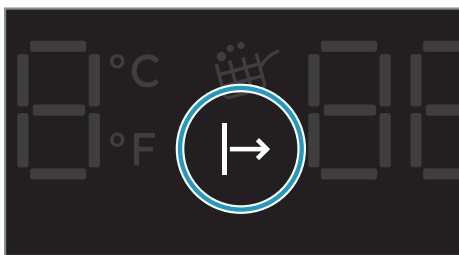

"Väntar på tillagning"-indikator

När "Funktion för Synkroniserat Slut" är aktiverad kommer korgen med kortare tillagningstid att vänta på tillagning tills korgen med längre tillagningstid tillagats ett tag, så att båda korgarna kan avsluta tillagningen samtidigt. Under denna period lyser "Väntar på tillagning" -indikatorn tills tillagningen börjar.

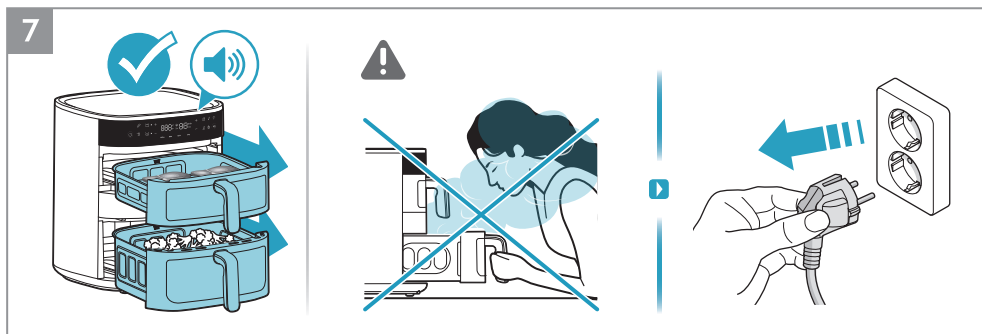

7. I slutet av tillagningstiden kommer apparaten att avge en pipsignal. Koppla ur apparaten efter användning.

GB
BG
DE
ES
FR
GR
IT
PT
NL
CA
SE
FI
DK
NO
HU
AR

Rengöring

1

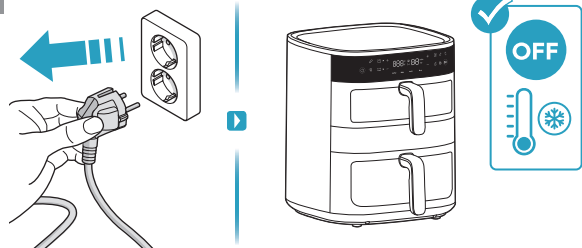

1. Koppla alltid ur apparaten och vänta tills den har svalnat innan du rengör den.
2. Torka av utsidan av apparaten med en mjuk trasa.

2



3

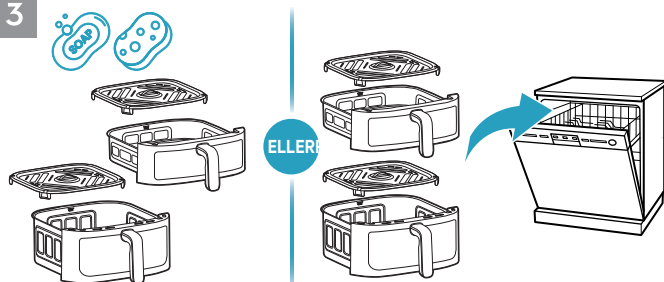

3. Rengör pannan och gallret med varmt vatten och diskmedel, eller placera dem i diskmaskinen.

⚠OBSERVERA: Undvik att använda slipande rengöringsprodukter eller metallverktyg för att skydda non-stick-beläggningen.

FÖRSIKTIGHET: Sänk aldrig ner produkten, sladden eller kontakten i vatten eller annan vätska.



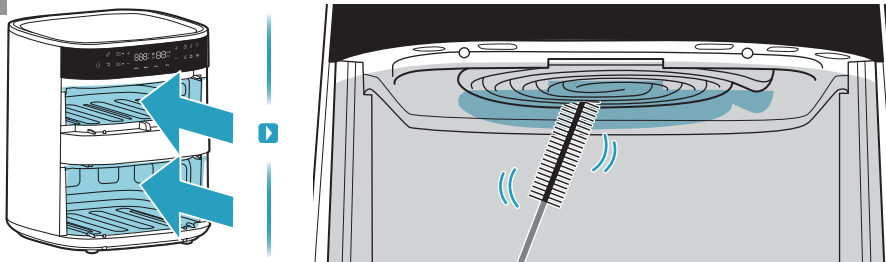









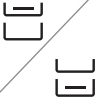

























4























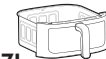

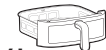
4. Rengör värmeelementet med en rengöringsborste.

OBSERVERA: Se till att apparaten är helt sval innan du rengör värmeelementet.

Tillagningsguide

							
AirFry	7mm/10mm 	4L 	400g	180 °C	18min		
		7L 	400g	180 °C	18min		
AirFry		4L 	400g	170 °C	8min		
		7L 	400g	170 °C	10min		
AirFry		4L 	400g/2st	140 °C	15min		
		7L 	400g/2st	140 °C	15min		
AirFry		4L 	1000g/8st	180 °C	28min		
		7L 	1000g/8st	180 °C	28min		
AirFry		4L 	400g/2st	200 °C	10min		
		7L 	400g/2st	200 °C	10min		
AirFry		4L 	220g/6cm	160 °C	12min		
		7L 	220g/6cm	160 °C	14min		

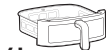
- GB
- BG
- DE
- ES
- FR
- GR
- IT
- PT
- NL
- CA
- SE
- FI
- DK
- NO
- HU
- AR

Recipe							
AirFry		 7L	1200g	180 °C	55min		
AirFry		 7L	400g/9st	160 °C	20min		
Grill		 4L	180g/4st	180 °C	8min		
		 7L	180g/4st	180 °C	9min		
Dry		 4L	180g	80 °C	3tim		
		 7L	180g	80 °C	3tim		
Dry		 4L	200g	80 °C	3tim		
		 7L	200g	80 °C	3tim		

GB
BG
DE
ES
FR
GR
IT
PT
NL
CA
SE
FI
DK
NO
HU
AR

Vad man ska göra om...

Problem	Kontrollera om...
Du inte kan starta eller använda apparaten.	<ul style="list-style-type: none">• Apparaten är korrekt ansluten till ett eluttag.• Korgarna är i rätt position. Se till att de är helt inskjutna i apparaten för att möjliggöra strömförsörjningen.• Tillagningstiden är inställd.
Du inte kan skjuta in korgen i apparaten.	<ul style="list-style-type: none">• Korgen är fylld över sin maxgräns.• Korgen är korrekt placerad. Det måste klicka när du sätter in den i enheten.• Det finns ett föremål under korgen som hindrar den från att stängas ordentligt.
Det kommer ut vit rök ur apparaten.	<ul style="list-style-type: none">• Maten du lagar är för fet.• Korgen, gallret och värmeelementet är rena.
Bildskärmen visar E1	<ul style="list-style-type: none">• Övre korg öppen krets.
Bildskärmen visar E2	<ul style="list-style-type: none">• Övre korg kortsluten.
Bildskärmen visar E3	<ul style="list-style-type: none">• Nedre korg öppen krets.
Bildskärmen visar E4	<ul style="list-style-type: none">• Nedre korg kortsluten.
Bildskärmen visar E5	<ul style="list-style-type: none">• Kommunikationsfel PCBA-styrkort.
Bildskärmen visar E6	<ul style="list-style-type: none">• Kommunikationsfel Power PCBA.

* Om displayen visar felkoder måste apparaten repareras av ett servicecenter.

Tekniska data

Produkt	Varmluftsfritös
Modell	AAFD11B
Spänning (V~)	220 V ~ 240 V
Effekt (W)	2700 W
Frekvens (Hz)	50 ~ 60 Hz
Kapacitet	4 L + 7 L

GB

BG

DE

ES

FR

GR

IT

PT

NL

CA

SE

FI

DK

NO

HU

AR



Ohjekirja

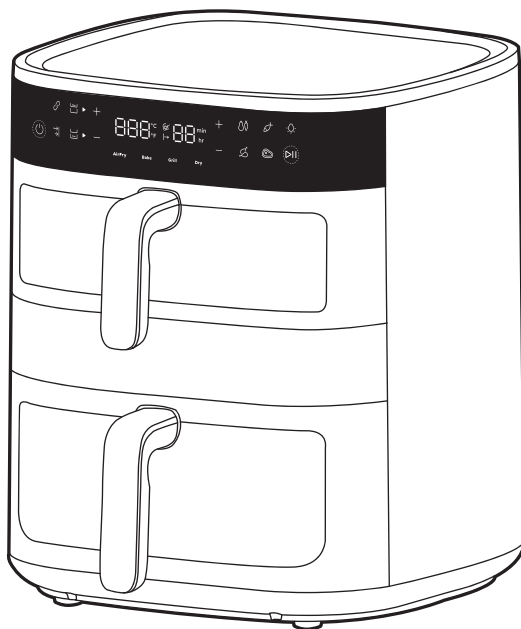

800 Air Fryer Dual

Yleiskatsaus

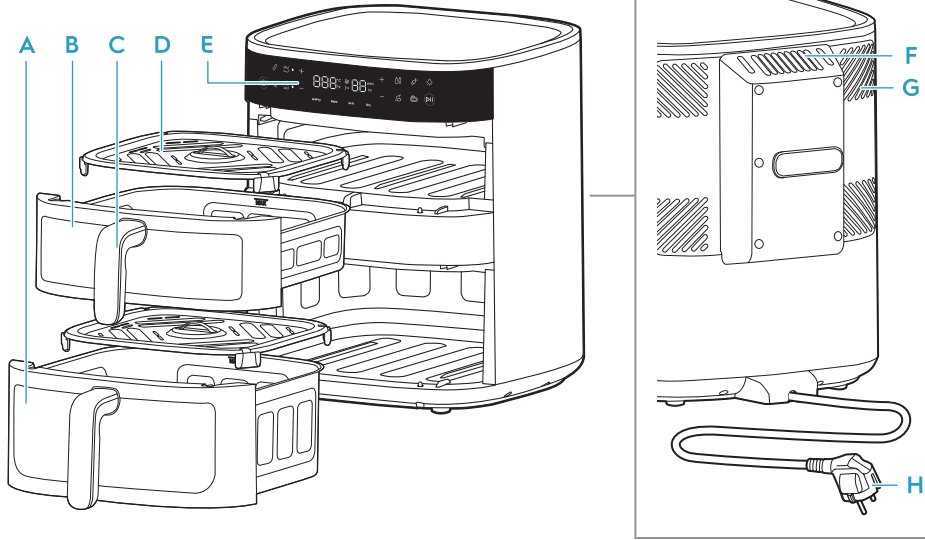

- | | | | |
|------------------------|----------------------|---------------------------|-------------------------------|
| A Alakori (7 l) | C Korin kahva | E Ohjauspaneeli | G Jäähdytysjärjestelmä |
| B Yläkori (4 l) | D Ruudukko | F Ilmanpoistoaukko | H Pääjohto |

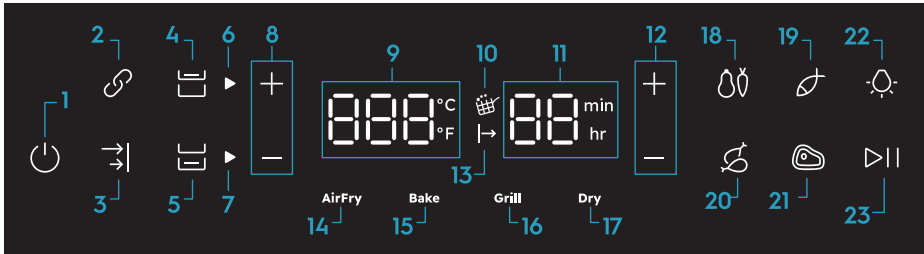

- | | | | |
|---------------------------------|--|--------------------------|---------------------|
| 1. On/Off (Päälle/Pois) | 8. Lämpötilan hallinta | 12. Aikavalvonta | 20. Kana |
| 2. Linkkitoiminto | 9. Lämpötilan ilmaisin (40–200 °C) | 13. Odottaa ruoanlaittoa | 21. Pihvi |
| 3. Synkronoinnin päättötoiminto | 10. Ravistusmuistutus | 14. AirFry-toiminto | 22. Valon hallinta |
| 4. Yläkorin hallinta | 11. Aikailmaisin (AirFry (Ilmakäristys): 1-99min, Dehydratointi: 1-5h) | 15. Paisto-toiminto | 23. Toista/Keskeytä |
| 5. Alakorin hallinta | | 16. Grillitoiminto | |
| 6. Yläkorin ilmaisin | | 17. Kuivaustoiminto | |
| 7. Alakorin ilmaisin | | 18. Vihannekset | |
| | | 19. Kala | |

Ennen ensimmäistä käyttöä

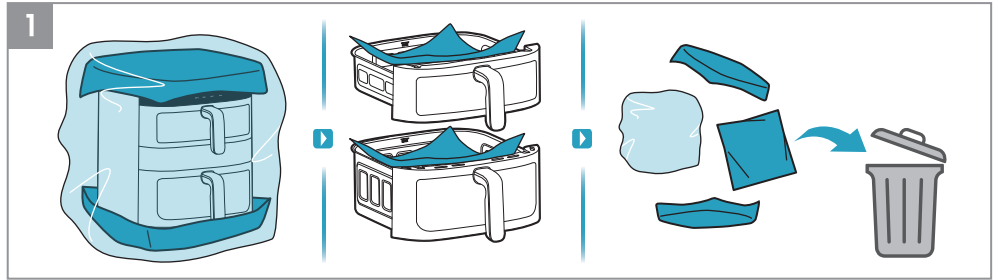

1. Poista kaikki pakkaus- ja suojamateriaalit.

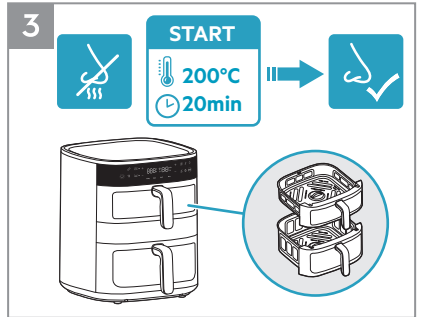
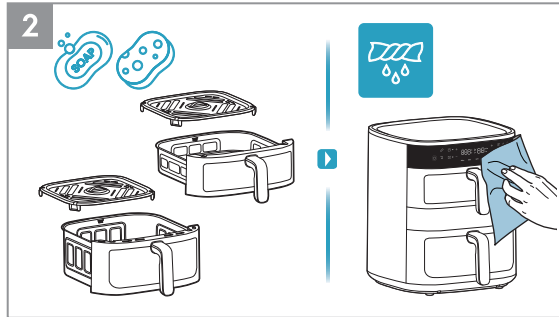



2. Puhdista pannu ja ritilä lämpimällä vedellä ja astianpesuaineella. Pyyhi laitteen sisä- ja ulkopinnat pehmeällä liinalla.
3. On normaalia, että uusi laite tuottaa hajua ensimmäisten käyttökertojen aikana. Käynnistä tyhjä ilmakeitin 200 °C:ssa 20 minuutin ajan ennen ensimmäistä käyttökertaa, jotta vältät tämän.

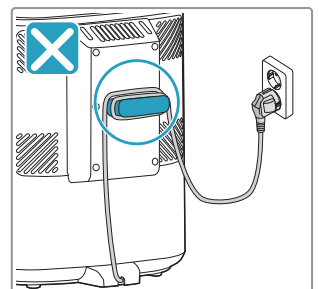
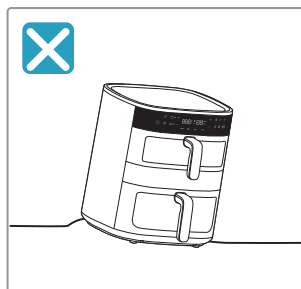
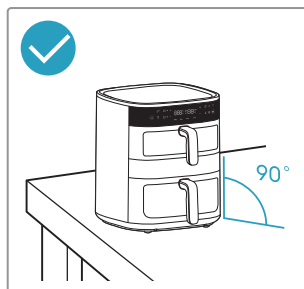
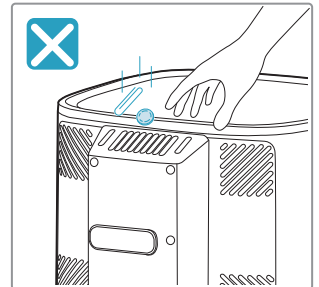
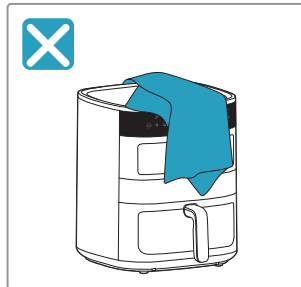
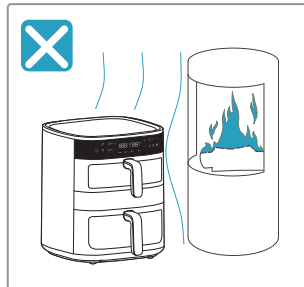



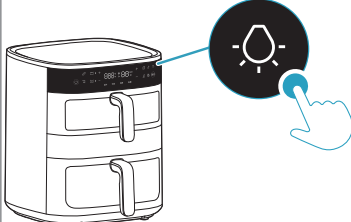
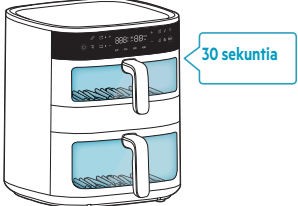

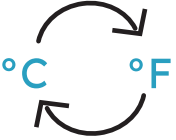



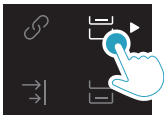



! Turvallisuuden varotoimet



Valaistuksen ohjaus ja lämpötila-asteikon muunnos

 <p>Valaistuksen ohjaus</p>		 <p>30 sekuntia</p>
<p>°C/°F</p> <p>Lämpötila-asteikon muuntaminen</p>	 <p>30 sekuntia</p>	

Korin valinta

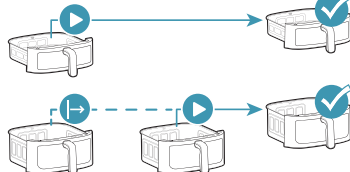
	 <p>4l</p>	 <p>7l</p>	
 <p>Yläkori</p>			
 <p>Alakori</p>			
 <p>Linkkitoiminto</p>			
 <p>Synkronoinnin päättötoiminto</p>			

GB

BG

DE

ES

FR

GR

IT

PT

NL

CA

SE

FI











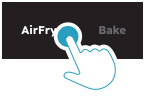



DK

NO

HU

AR

Valmiit toiminnot

					
Air Fry	180°C	15min	60-200°C	1-99min	
	170°C	10min	60-200°C	1-99min	
	140°C	15min	60-200°C	1-99min	
	180°C	30min	60-200°C	1-99min	
	200°C	10min	60-200°C	1-99min	
Bake	170°C	15min	60-200°C	1-99min	
Grill	200°C	5min	60-200°C	1-99min	
Dry	80°C	5h	40-80°C	1-5h	

GB
BG
DE
ES
FR
GR
IT
PT
NL
CA
SE
FI
DK
NO
HU
AR

Ennen kypsennystä

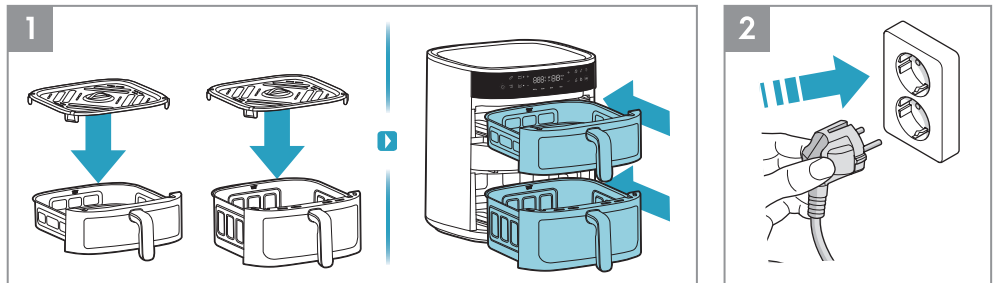

1. Ennen jokaista kypsennystä aseta ritilä koriin (ritilän lämmönkestävää silikonijalkapohjaa ei tarvitse poistaa) ja tyynnä kori kokonaan laitteeseen.
2. Kytke virtajohto pistorasiaan.

Käyttöohjeet - Yksittäinen kori

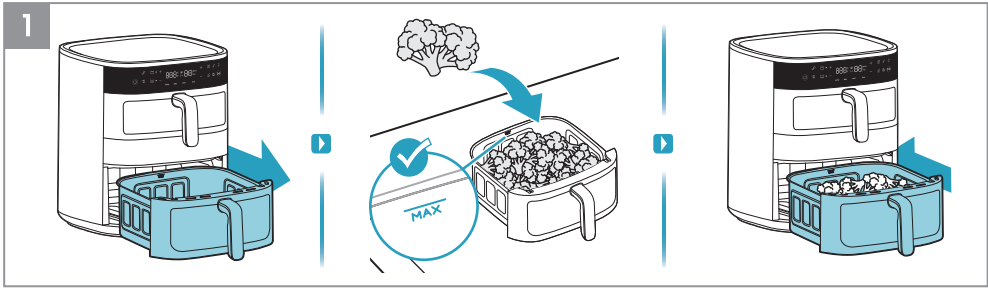

1. Vedä yksi kori ulos ja aseta se vakaalle alustalle, laita ruoka koriin noudattaen "MAX" -kapasiteettimerkkiä. Työnnä sitten kori, jossa on ruokaa kokonaan takaisin laitteeseen.



2. Paina Päälle/Pois-painiketta. Valitse ensin kori, jossa on ruokaa. Valitse sitten haluamasi kypsennysmenetelmä, esimerkiksi Air Fry -toiminto. Säädä aika ja lämpötila makusi mukaan tai valitse yksi valmiista resepteistä, esimerkiksi Vihannekset. Lopuksi paina Toisto/Keskeytyks-painiketta.

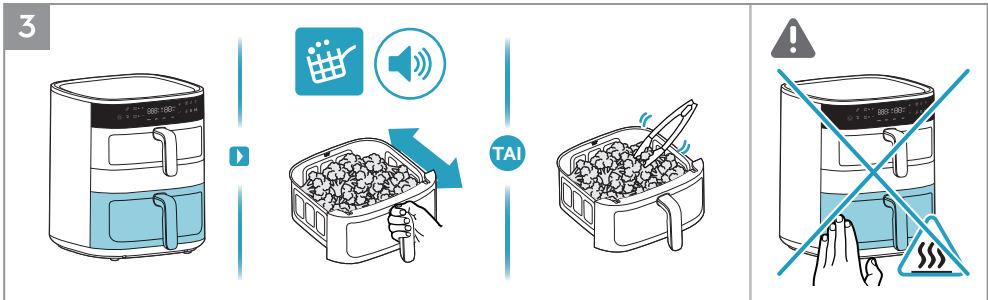

3. Kun "Ravistusmuistutus" -kuvake syttyy ja antaa äänimerkin ruoanlaittoprosessin aikana, käännä ruoka kerran lämmönkestävillä välineillä tai ravista ruoka varovasti hieman paistokorissa.

⚠ **VAROITUS:** Älä ravista paistokoria voimakkaasti, jotta ruoka ei roisku ja aiheuta palovammoja.

⚠ **VAROITUS:** Ole varovainen kuumien pintojen kanssa, kun laite on käytössä.

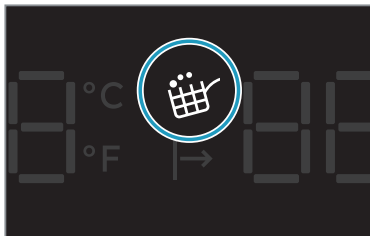

Ravistusmuistutus

"Ravistusmuistutus" aktivoituu Air Fry -toiminnon ja valmiiden reseptien, kuten vihannesten, kalan, kanankoipien ja pihvin, aikana.

Kun on aika ravistaa tai kääntää ruokaa, "Ravistusmuistutus" -kuvake syttyy ja vilkkuu minuutin ajan, samalla kun äänimerkki toistuu kolme kertaa.

"Ravistusmuistutus" ei ole pakollinen, joten ruoanlaitto jatkuu normaalisti, vaikka ruokaa ei käännettäisi tai ravistettaisi.

4



4. Kun kypsennysaika on päättynyt, laite antaa äänimerkin. Poista kori varovasti ja aseta se lämmönkestävälle alustalle. Irrota laite pistorasiasta käytön jälkeen.

⚠ **VAROITUS:** Koriin voi tulla kuumaa höyryä, kun se avataan kypsennyksen keskivaiheilla tai lopussa. Varmista, että kasvossi, käsivartesi ja kätesi ovat kaukana höyrystä, kun avaat sen.

Käyttöohjeet - Ylä- ja alakori

1

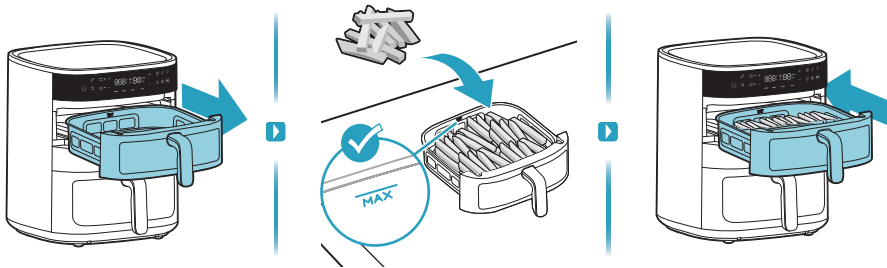

1. Ensinnäkin, vedä yläkori ulos ja laita ruoka koriin, esimerkiksi ranskalaiset perunat.

2

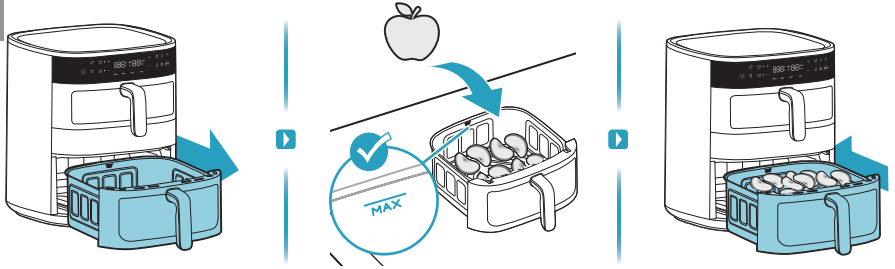

2. Toiseksi, vedä alakori ulos ja laita ruoka koriin, esimerkiksi omenaviipalet.

3



3. Paina virtapainiketta. Valitse ensin yläkori. Valitse sitten haluamasi kypsennysmenetelmä, esimerkiksi Air Fry -toiminto. Säädä aika ja lämpötila mukaksi mukaan tai valitse yksi valmiista resepteistä, esimerkiksi Vihannekset. Lopuksi paina Toisto/Tauko-painiketta.



4. Toiseksi, valitse alakori. Valitse sitten haluamasi kypsennysmenetelmä, esimerkiksi kuivaustoiminto. Säädä aika ja lämpötila makusi mukaan. Lopuksi paina Toisto/Tauko-painiketta.

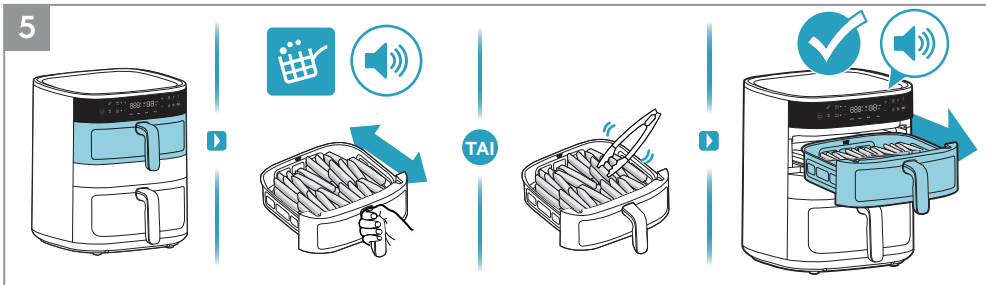

5. Kun "Ravistusmuistutus" -kuvake syttyy ja antaa äänimerkin ruoanlaittoprosessin aikana, käännä ruoka kerran lämmönkestävillä välineillä tai ravista ruoka varovasti hieman paistokorissa. Kun yläkorin kypsennysaika on päättynyt, laite antaa äänimerkin.

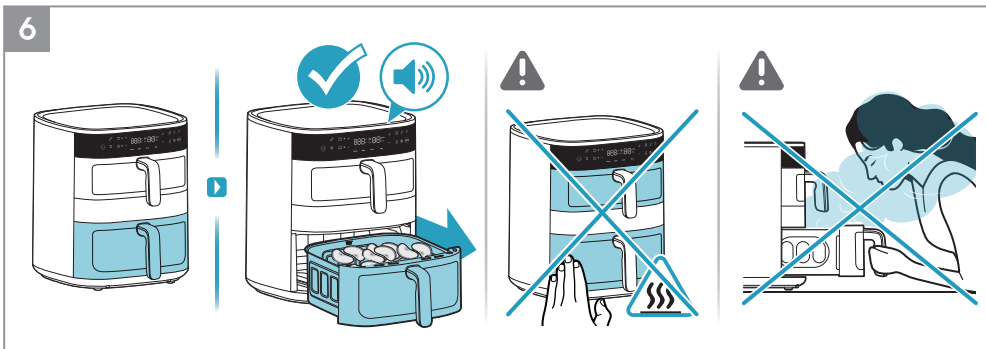

6. Kun alakorin kypsennysaika on päättynyt, laite antaa äänimerkin.

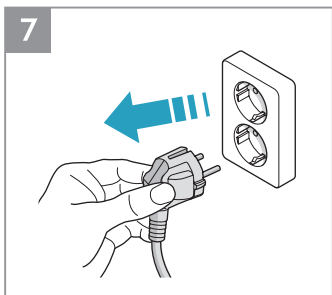

7. Irrota laite pistorasiasta käytön jälkeen.

GB
BG
DE
ES
FR
GR
IT
PT
NL
CA
SE
FI
DK
NO
HU
AR

Käyttöohjeet - Linkkitoiminto

1

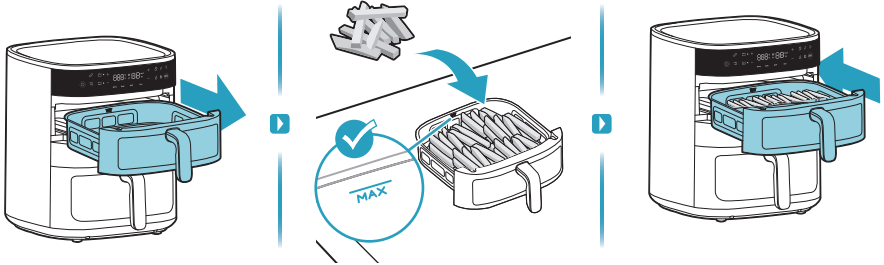

1. Ensinnäkin, vedä yläsäiliö ulos ja laita ruoka säiliöön, esimerkiksi ranskalaiset perunat.

2

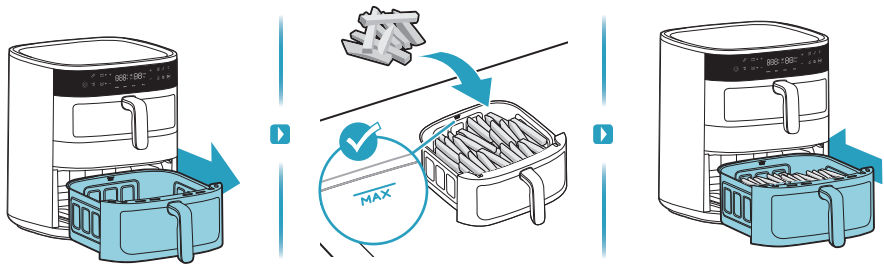

2. Toiseksi, vedä alakori ulos ja laita ruoka koriin, esimerkiksi ranskalaiset perunat.

3

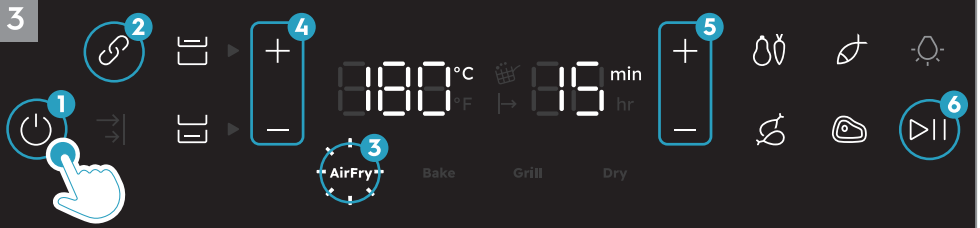

3. Paina virtapainiketta. Valitse ensin linkkitoiminto. Valitse sitten haluamasi kypsennysmenetelmä, esimerkiksi Air Fry -toiminto. Säädä aika ja lämpötila makusi mukaan tai valitse yksi valmiista resepteistä. Lopuksi paina Toisto/Tauko-painiketta.

4

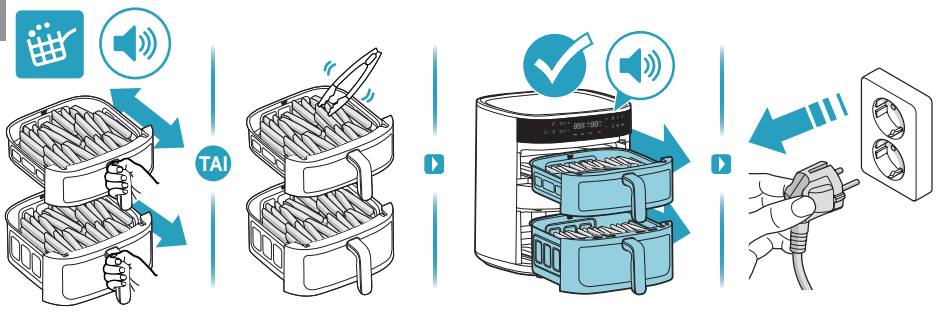

4. Kun "Ravistusmuistutus" -kuvake syttyy ja antaa äänimerkin ruoanlaittoprosessin aikana, käännä ruoka kerran lämmönkestävillä välineillä tai ravista ruoka varovasti hieman paistakorissa. Kun kypsennysaika on päättynyt, laite antaa äänimerkin. Irrota laite pistorasiasta käytön jälkeen.

GB
BG
DE
ES
FR
GR
IT
PT
NL
CA
SE
FI
DK
NO
HU
AR

Käyttöohjeet - Synkronoinnin päättötoiminto

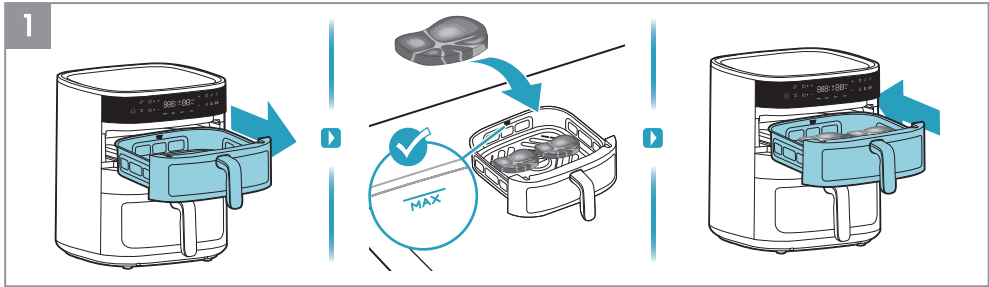

1. Ensinnäkin, vedä yläkori ulos ja laita ruoka koriin, esimerkiksi pihvi.

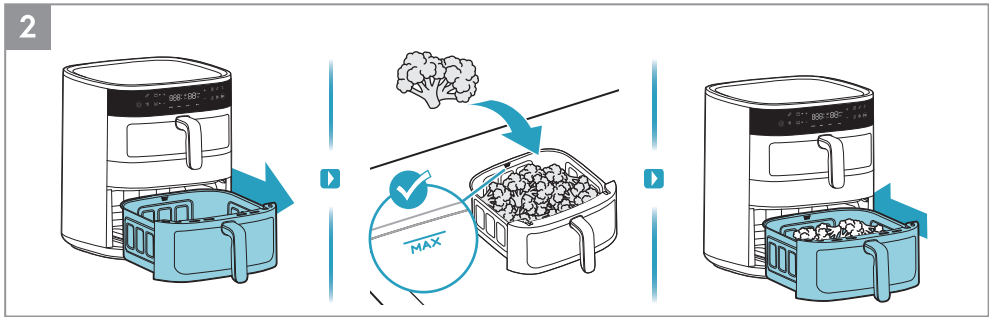

2. Toiseksi, vedä alakori ulos ja laita ruoka koriin, esimerkiksi parsakaali.



3. Paina Päälle/Pois-painiketta. Valitse Synkronoinnin päättötoiminto. Valitse ensin yläkori ja sitten haluamasi kypsennysmenetelmä, esimerkiksi Air Fry -toiminto. Säädä aika ja lämpötila makusi mukaan tai valitse yksi valmiista resepteistä, esimerkiksi pihvi.

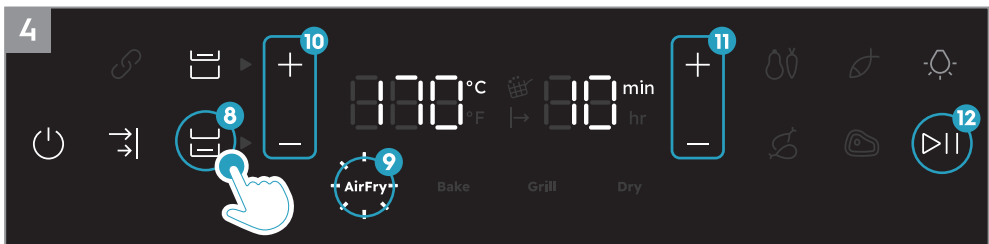

4. Valitse sitten alakori ja haluamasi kypsennysmenetelmä, esimerkiksi Air Fry -toiminto. Säädä aika ja lämpötila makusi mukaan tai valitse yksi valmiista resepteistä. Lopuksi paina Toisto/Tauko-painiketta.

GB
BG
DE
ES
FR
GR
IT
PT
NL
CA
SE
FI
DK
NO
HU
AR

5

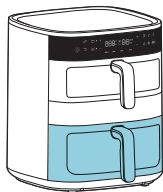

TAI



5. Ensinnäkin, alakori, jonka asetusaika on pidempi, asetetaan etusijalle ruoanlaittoa varten. Kun "Ravistusmuistutus"-kuvake syttyy ja antaa äänimerkin ruoanlaittoprosessin aikana, käännä ruoka kerran lämmönkestävillä välineillä tai ravista ruoka varovasti hieman paistokorissa.

6

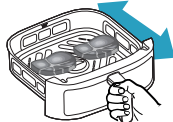
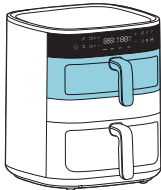

TAI

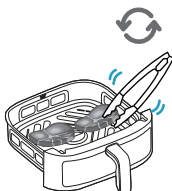

6. Toiseksi, lyhyemmällä asetusaajalla varustettu yläkori alkaa kypsentää. Kun "Ravistusmuistutus"-kuvake syttyy ja antaa äänimerkin ruoanlaittoprosessin aikana, käännä ruoka kerran lämmönkestävillä välineillä tai ravista ruoka varovasti hieman paistokorissa.

Odottaminen ruoanlaittoon -ilmais

Kun "Synkronoinnin päättötoiminto" on aktivoitu, korin, jonka kypsennysaika on lyhyempi, kypsennys odottaa, kunnes korin, jonka kypsennysaika on pidempi, kypsennys on kestänyt jonkin aikaa, jotta molempien korien kypsennys päättyy samaan aikaan. Tänä aikana "Odottaminen ruoanlaittoon -ilmais" palaa, kunnes kypsennys alkaa.

7

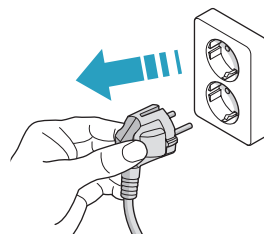

7. Kun kypsennysaika on päättynyt, laite antaa äänimerkin. Irrota laite pistorasiasta käytön jälkeen.

Puhdistus

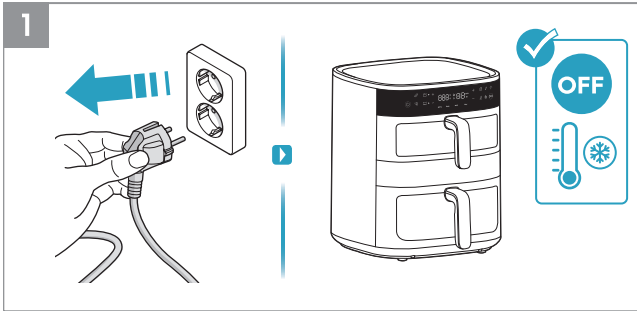

1. Irrota laite aina pistorasiasta ja odota, että se jäähtyy, ennen kuin puhdistat sen.
2. Pyyhi laitteen ulkopinta pehmeällä liinalla.

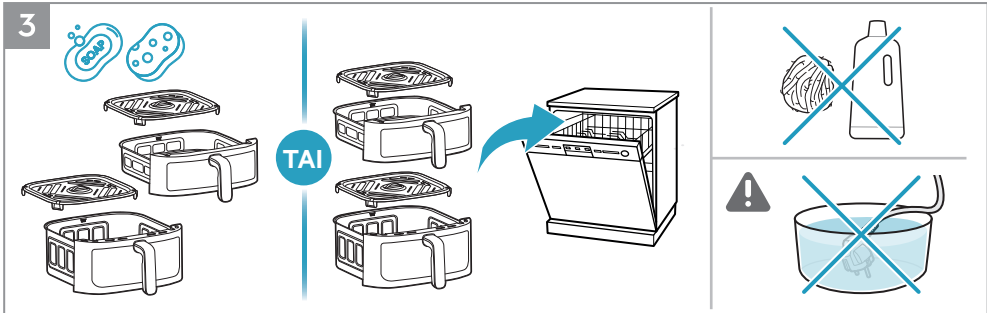
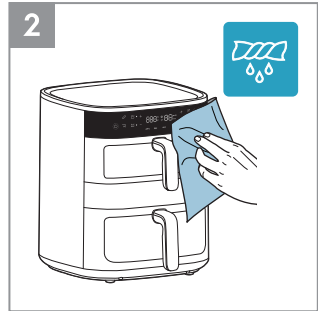

3. Puhdista panna ja ritilä lämpimällä vedellä ja astianpesuaineella tai laita ne astianpesukoneeseen.

⚠HUOMAUTUS: Vältä hankaavien puhdistusaineiden tai metallisten työkalujen käyttöä, jotta tarttumaton pinnoite säilyy ehjänä.

VAROITUS: Älä koskaan upota tuotetta, sen johtoa tai pistoketta veteen tai muuhun nesteeseen.

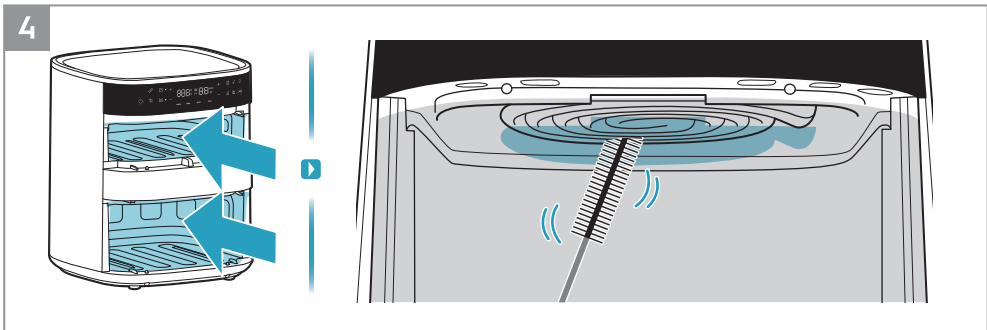

4. Puhdista lämmityselementti puhdistusharjalla.

HUOMAUTUS: Varmista, että laite on täysin jäähtynyt ennen lämmityselementin puhdistamista.

GB

BG

DE

ES

FR

GR

IT

PT

NL

CA

SE

FI































DK

NO

























HU

AR

Ruoanlaitto-opas

Recipe							
AirFry	7mm/10mm 	4l 	400g	180 °C	18min		
		7l 	400g	180 °C	18min		
AirFry		4l 	400g	170 °C	8min		
		7l 	400g	170 °C	10min		
AirFry		4l 	400g/2kpl	140 °C	15min		
		7l 	400g/2kpl	140 °C	15min		
AirFry		4l 	1000g/8kpl	180 °C	28min		
		7l 	1000g/8kpl	180 °C	28min		
AirFry		4l 	400g/2kpl	200 °C	10min		
		7l 	400g/2kpl	200 °C	10min		
AirFry	 	4l 	220g/6tuumaa	160 °C	12min		
		7l 	220g/6tuumaa	160 °C	14min		

GB
BG
DE
ES
FR
GR
IT
PT
NL
CA
SE
FI
DK
NO
HU
AR

							
AirFry		 7l	1200g	180 °C	55min		
AirFry		 7l	400g/9kpl	160 °C	20min		
Grill		 4l	180g/4kpl	180 °C	8min		
		 7l	180g/4kpl	180 °C	9min		
Dry		 4l	180g	80 °C	3h		
		 7l	180g	80 °C	3h		
Dry		 4l	200g	80 °C	3h		
		 7l	200g	80 °C	3h		

GB
 BG
 DE
 ES
 FR
 GR
 IT
 PT
 NL
 CA
 SE
FI
 DK
 NO
 HU
 AR

Mitä tehdä, jos...

Ongelma	Tarkista, onko...
Laitetta ei voi aktivoida tai käyttää.	<ul style="list-style-type: none">• Laite on kytketty oikein sähköverkkoon.• Korit ovat oikeassa asennossa. Varmista, että ne on työnnetty kokonaan laitteeseen, jotta virta kytkeytyy päälle.• Kypsennysaika on asetettu.
Koria ei voi työntää laitteeseen.	<ul style="list-style-type: none">• Kori on täytetty yli sen maksimikapasiteetin.• Kori on asetettu oikein. Sen on napsahdettava paikalleen, kun asetat sen laitteeseen.• Korin alla on esine, joka estää sen sulkeutumisen kunnolla.
Laitteesta tulee valkoista savua.	<ul style="list-style-type: none">• Valmistamasi ruoka on liian rasvainen.• Kori, ritilä ja lämmityselementti ovat puhtaat.
Näyttöön tulee E1	<ul style="list-style-type: none">• Yläkorin avoin piiri.
Näyttöön tulee E2	<ul style="list-style-type: none">• Yläkorin oikosulku.
Näyttöön tulee E3	<ul style="list-style-type: none">• Alakorin avoin piiri.
Näyttöön tulee E4	<ul style="list-style-type: none">• Alakorin oikosulku.
Näyttöön tulee E5	<ul style="list-style-type: none">• Ohjaus PCBA-viestinnän vika.
Näyttöön tulee E6	<ul style="list-style-type: none">• Virran PCBA -viestintävirhe.

* Jos näytössä näkyy virhekoodeja, laite on korjattava huoltokeskuksessa.

Tekniset tiedot

Tuote	Air Fryer
Malli	AAFD11B
Jännite (V~)	220 V ~ 240 V
Teho (W)	2700 W
Taajuus (Hz)	50 ~ 60 Hz
Kapasiteetti	4 L + 7 L

GB

BG

DE

ES

FR

GR

IT

PT

NL

CA

SE

FI

DK

NO

HU

AR



Instruktionsbog

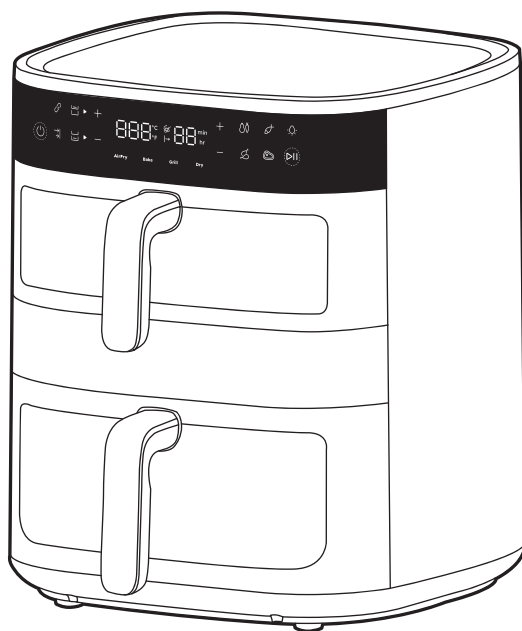

800 Air Fryer Dual

Generelt oversigt

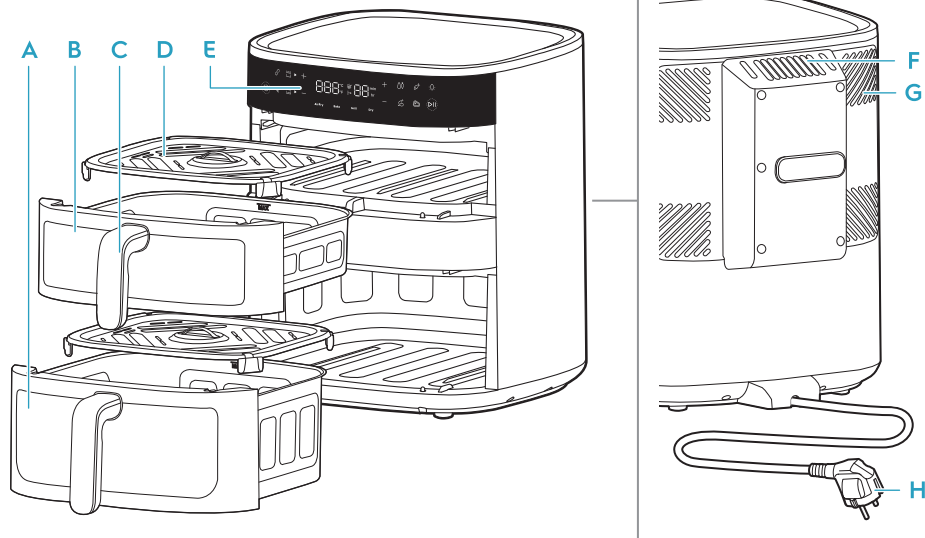

- | | | | |
|------------------------------|---------------------------|-----------------------|-----------------------|
| A Nederste kurv (7 L) | C Håndtag til kurv | E Kontrolpanel | G Kølesystem |
| B Øverste kurv (4L) | D Gitter | F Luftudtag | H Hovedledning |

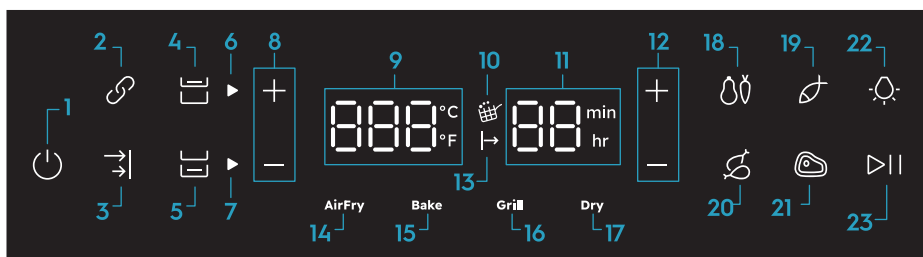

- | | | |
|-------------------------------|---|-----------------------|
| 1. Tænd/sluk | 9. Temperaturindikator (40-200 °C) | 16. Grill-funktion |
| 2. Link-funktion | 10. Påmindelse om at ryste | 17. Tørringsfunktion |
| 3. Synkroniser slut-funktion | 11. Tidsindikator
(AirFry: 1-99 min., Dehydrering: 1-5 t.) | 18. Grøntsager |
| 4. Styring af øverste kurv | 12. Tidsstyring | 19. Fisk |
| 5. Styring af nederste kurv | 13. Venter på at lave mad | 20. Kylling |
| 6. Indikator for øverste kurv | 14. AirFry-funktion | 21. Bøf |
| 7. Indikator nederste kurv | 15. Bagefunktion | 22. Belysningsstyring |
| 8. Temperaturstyring | | 23. Afspil/Pause |

Før første brug

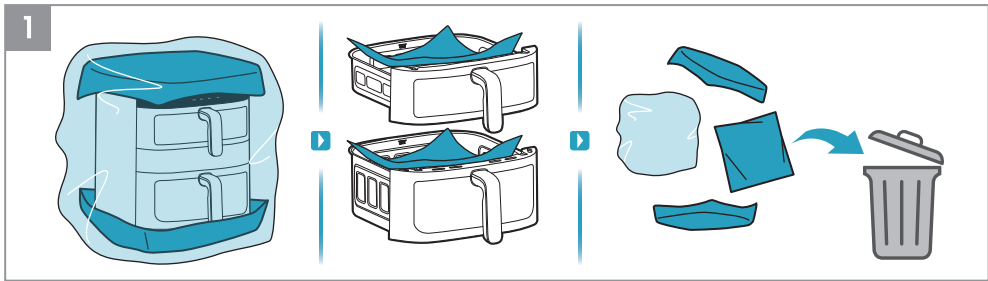

1. Fjern al emballage og beskyttelsesmateriale.

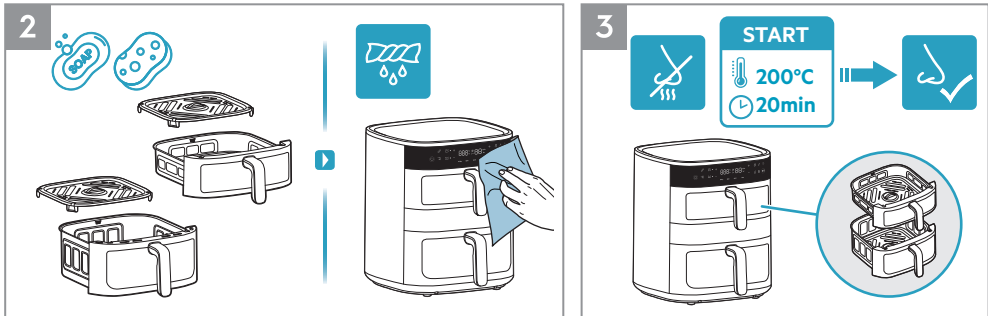

2. Rengør pande og rist med varmt vand og opvaskemiddel. Tør apparatet af indvendigt og udvendigt med en blød klud.

3. Det er normalt, at en ny enhed afgiver lugt de første gange, den anvendes. Kør den tomme airfryer ved 200 °C i 20 minutter før første brug for at undgå dette.

! Sikkerhedsforanstaltninger

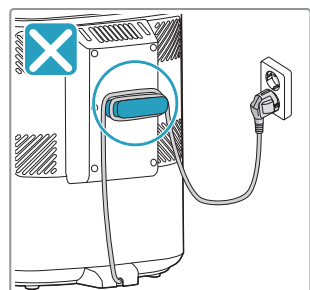
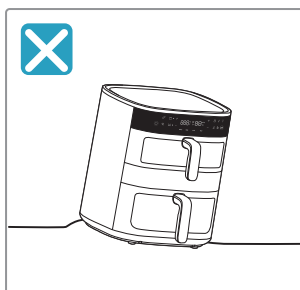
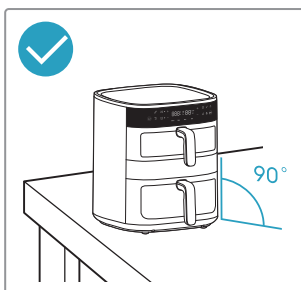
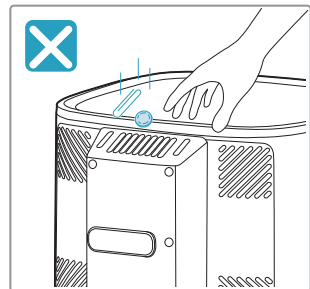
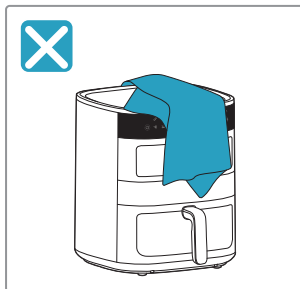
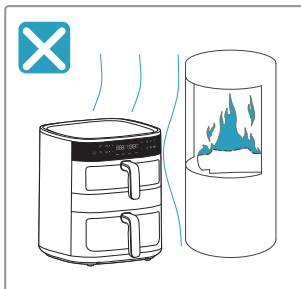

GB

BG

DE

ES

FR

GR

IT

PT

NL

CA

SE

FI



DK

NO





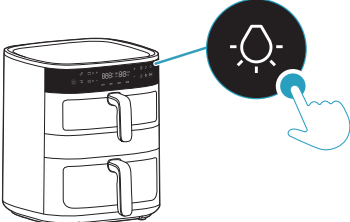
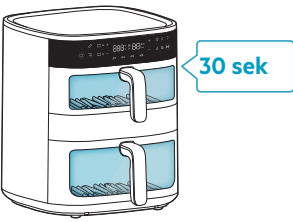

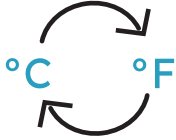



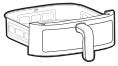

HU

AR

Belysningsstyring og konvertering af temperaturskala





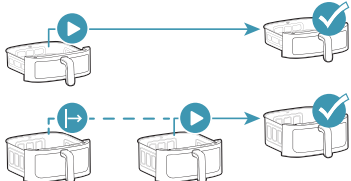









 <p>Belysningsstyring</p>		
<p>°C/°F</p> <p>Konvertering af temperaturskala</p>		

Valg af kurv

	 <p>4L</p>	 <p>7L</p>	
 <p>Øverste kurv</p>			
 <p>Nederste kurv</p>			
 <p>Link-funktion</p>			
 <p>Synkroniser slut-funktion</p>			

GB
BG
DE
ES
FR
GR
IT
PT
NL
CA
SE
FI
DK
NO
HU
AR

Forudindstillingsfunktioner

 AirFry					
AirFry	180°C	15min	60~200°C	1-99min	
	170°C	10min	60~200°C	1-99min	
	140°C	15min	60~200°C	1-99min	
	180°C	30min	60~200°C	1-99min	
	200°C	10min	60~200°C	1-99min	
Bake	170°C	15min	60~200°C	1-99min	
Grill	200°C	5min	60~200°C	1-99min	
Dry	80°C	5 timer	40~80°C	1-5timer	

GB

BG

DE

ES

FR

GR

IT

PT

NL

CA

SE

FI

DK

NO

HU

AR

Før tilberedning

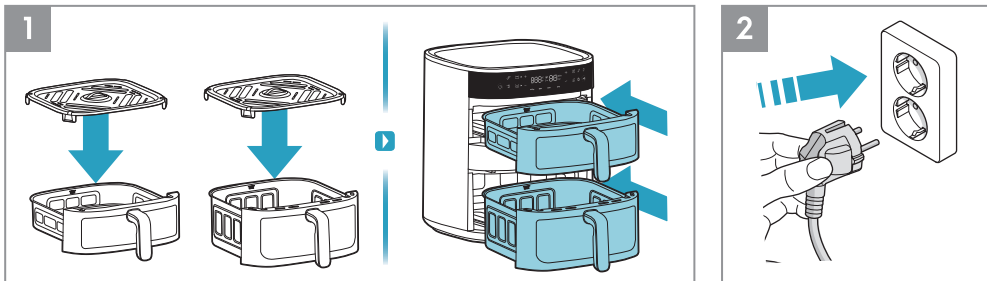

1. Før hver tilberedning skal risten placeres i kurven (den varmebestandige silikonefod på risten skal ikke fjernes), og kurven skubbes helt ind i apparatet.
2. Sæt strømstikket i stikkontakten.

Sådan bruges – enkelt kurv

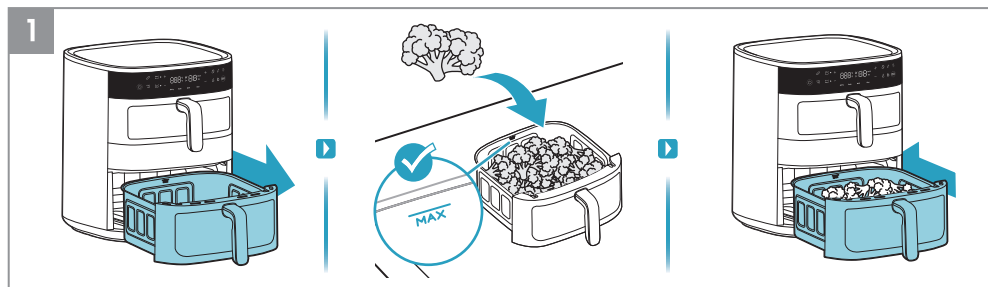

1. Træk en kurv ud, og placer den på en stabil overflade. Læg maden i kurven, og overhold kapacitetsangivelsen "MAX" (MAKS). Skub derefter kurven med maden helt tilbage i apparatet.



2. PTryk på Tænd/sluk-knappen. Vælg først kurven med mad. Vælg derefter den ønskede tilberedningsmetode, for eksempel Air Fry-funktionen. Juster tid og temperatur efter din smag, eller vælg en af de forudindstillede opskrifter, for eksempel Grøntsager. Tryk til sidst på Afspil/Pause-knappen.

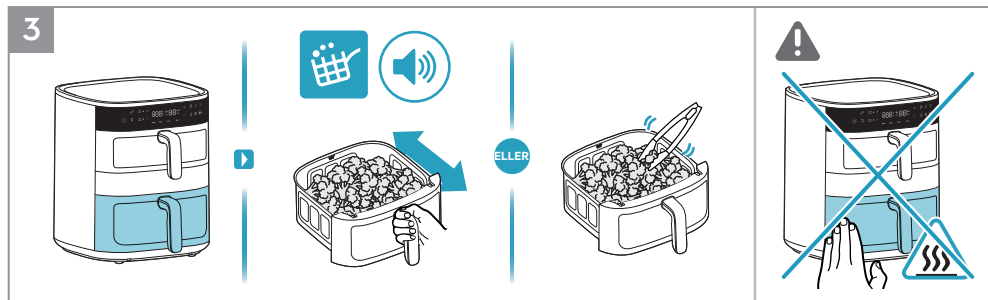

3. Når ikonet "Shake Reminder" (Påmindelse om at ryste) lyser og bipper under tilberedningen, skal du bruge varmebestandigt værktøj til at vende maden én gang eller forsigtigt ryste maden let i friturekurven.

- ⚠ **FORSIGTIG:** Ryst ikke friturekurven kraftigt for at undgå, at maden sprøjter ud og forårsager forbrændinger.
- ⚠ **FORSIGTIG:** Vær forsigtig med varme overflader, når apparatet er i brug.

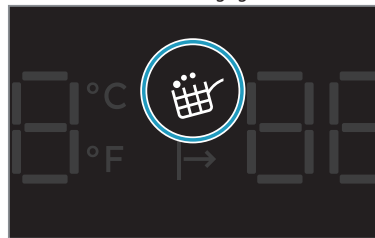

Påmindelse om at ryste

"Shake Reminder" (Påmindelse om at ryste) aktiveres under Air Fry-funktionen og de forudindstillede opskrifter, f.eks. grøntsager, fisk, kyllingelår og bøf.

Når det er tid til at ryste eller vende maden, vil ikonet "Shake Reminder" (Påmindelse om at ryste) lyse og blinke i ét minut, mens et bip gentages tre gange.

"Shake Reminder" (Påmindelse om at ryste) er ikke obligatorisk, derfor fortsætter tilberedningen som normalt, selv hvis maden ikke vendes eller rystes.



4. Ved afslutningen af tilberedningstiden afgiver apparatet et bip. Fjern forsigtigt kurven, og placer den på en varmebestandig overflade. Tag stikket ud af stikkontakten efter brug.

⚠ **FORSIGTIG:** Der kan komme varm damp ud af kurven, når den åbnes midt i eller i slutningen af tilberedningen. Sørg for, at ansigt, arme og hænder er væk fra dampen, når du åbner den.

Sådan bruges - øverste + nederste kurv

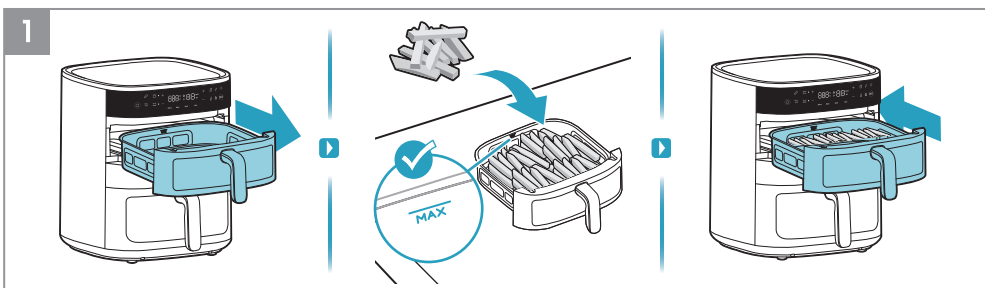

1. Træk først den øverste kurv ud, og læg maden i kurven, for eksempel pommes frites.

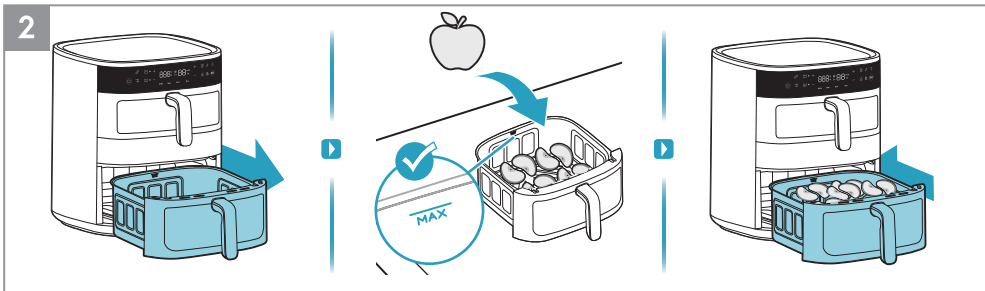

2. For det andet skal du trække den nederste kurv ud og lægge maden i kurven, for eksempel æbleskiver.



3. Tryk på Tænd/sluk-knappen. Vælg først den øverste kurv. Vælg derefter den ønskede tilberedningsmetode, for eksempel Air Fry-funktionen. Juster tid og temperatur efter din smag, eller vælg en af de forudindstillede opskrifter, for eksempel Grøntsager. Tryk til sidst på Afspil/Pause-knappen.

GB
BG
DE
ES
FR
GR
IT
PT
NL
CA
SE
FI
DK
NO
HU
AR



4. For det andet skal du vælge den nederste kurv. Vælg derefter den ønskede tilberedningsmetode, for eksempel Tørringsfunktionen. Juster tid og temperatur efter din smag. Tryk til sidst på Afspil/Pause-knappen.

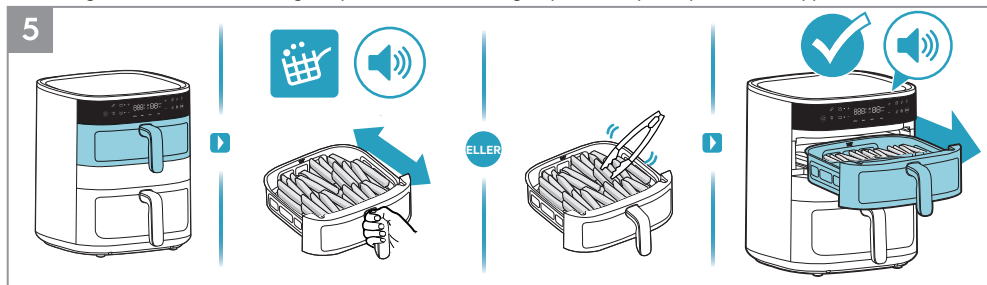

5. Når ikonet "Shake Reminder" (Påmindelse om at ryste) lyser og bipper under tilberedningen, skal du bruge varmebestandigt værktøj til at vende maden én gang eller forsigtigt ryste maden let i friturekurven. Ved afslutningen af tilberedningstiden for den øverste kurv afgiver apparatet et bip.

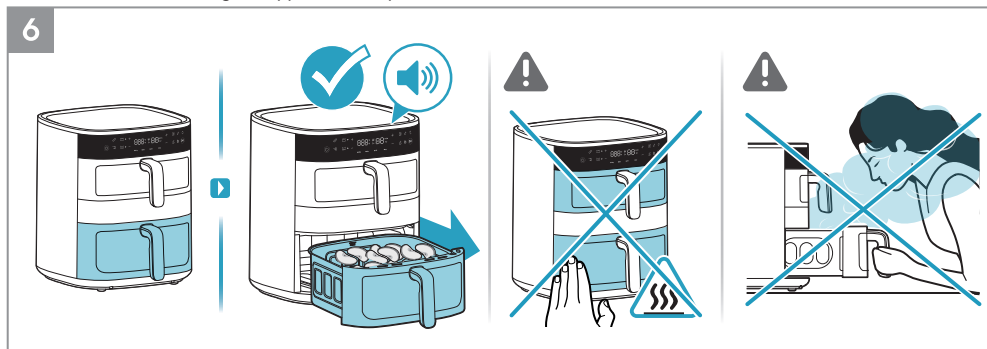

6. Når tilberedningstiden for den nederste kurv er slut, udsender apparatet et bipsignal.

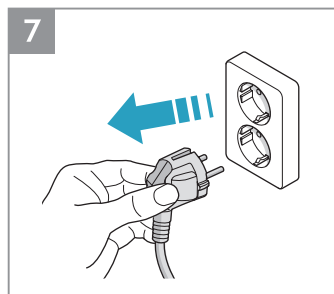

7. Tag stikket ud af stikkontakten efter brug.

Sådan bruges - Link-funktion

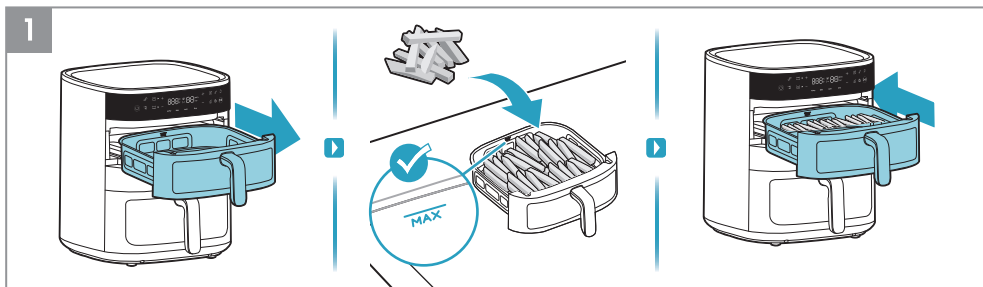

1. Træk først den øverste kurv ud, og læg maden i kurven, for eksempel pommes frites.

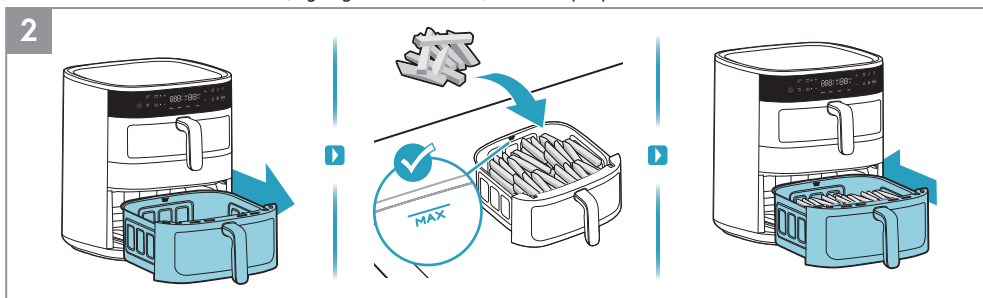

2. For det andet skal du trække den nederste kurv ud og lægge maden i kurven, for eksempel pommes frites.

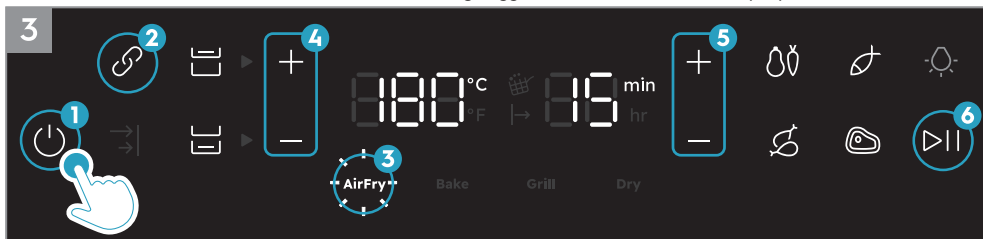

3. Tryk på Tænd/sluk-knappen. Vælg først link-funktionen. Vælg derefter den ønskede tilberedningsmetode, for eksempel Air Fry-funktionen. Juster tid og temperatur efter din smag, eller vælg en af de forudindstillede opskrifter. Tryk til sidst på Afspil/Pause-knappen.

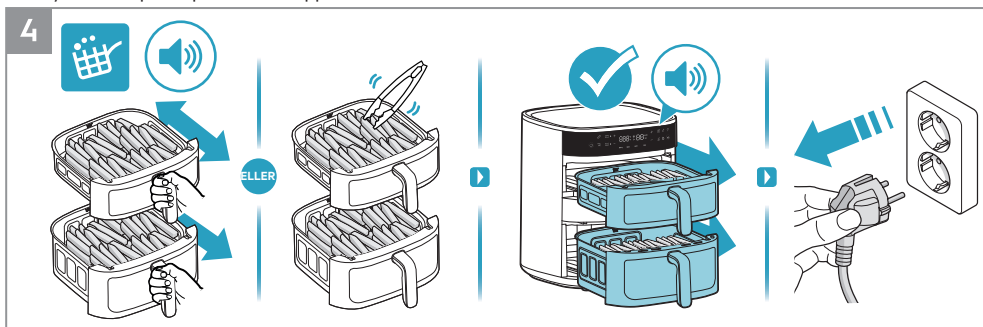

4. Når ikonet "Shake Reminder" (Påmindelse om at ryste) lyser og bipper under tilberedningen, skal du bruge varmebestandigt værktøj til at vende maden én gang eller forsigtigt ryste maden let i friturekurven. Ved afslutningen af tilberedningstiden afgiver apparatet et bip. Tag stikket ud af stikkontakten efter brug.

GB

BG

DE

ES

FR

GR

IT

PT

NL

CA

SE

FI

DK

NO

HU

AR

Sådan bruges - Synkroniser slut-funktion

1

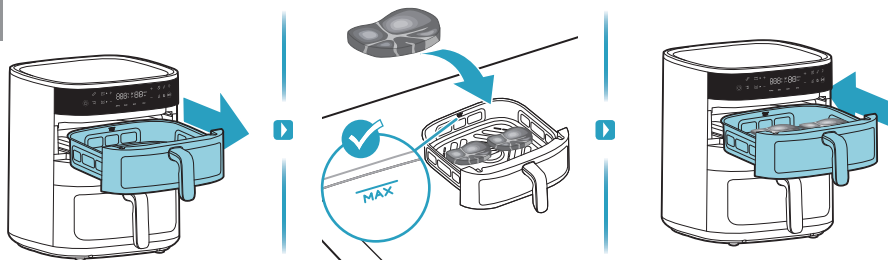

1. Træk først den øverste kurv ud, og læg maden i kurven, for eksempel en bøf.

2

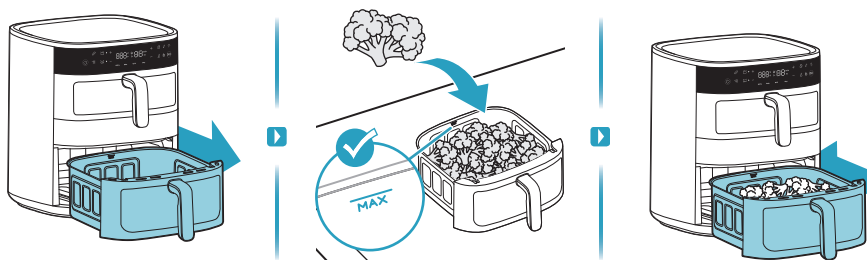

2. For det andet skal du trække den nederste kurv ud og lægge maden i kurven, for eksempel broccoli.

3

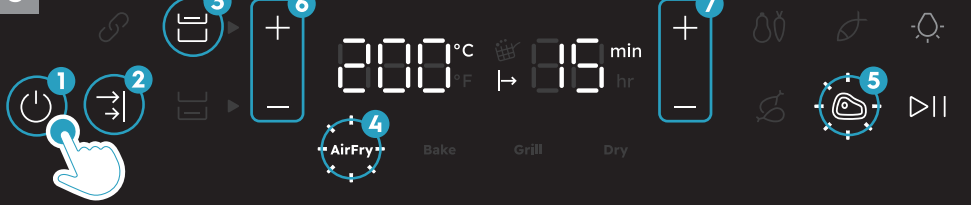

3. Tryk på Tænd/sluk-knappen. Vælg Synkroniser slut-funktion. Vælg først den øverste kurv, og vælg derefter den ønskede tilberedningsmetode, for eksempel Air Fry-funktionen. Juster tid og temperatur efter din smag, eller vælg en af de forudindstillede opskrifter, for eksempel Bøf.

4



4. Vælg derefter den nederste kurv, og vælg den ønskede tilberedningsmetode, for eksempel Air Fry-funktionen. Juster tid og temperatur efter din smag, eller vælg en af de forudindstillede opskrifter. Tryk til sidst på Afspil/Pause-knappen.

GB
BG
DE
ES
FR
GR
IT
PT
NL
CA
SE
FI
DK
NO
HU
AR

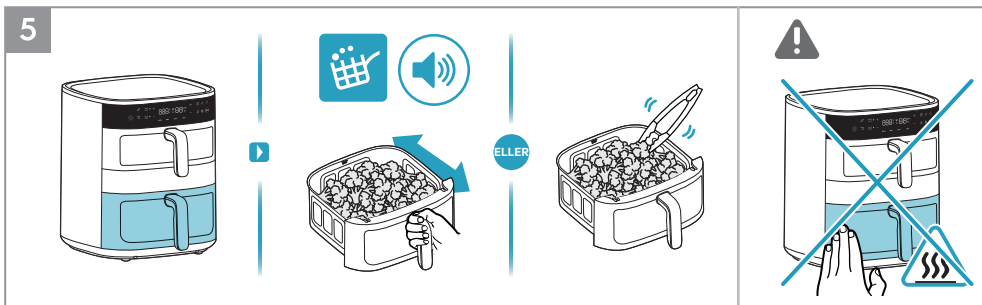

5. Først vil den nederste kurv med den længste indstillede tilberedningstid blive prioriteret til tilberedning. Når ikonet "Shake Reminder" (Påmindelse om at ryste) lyser og bipper under tilberedningen, skal du bruge varmebestandigt værktøj til at vende maden én gang eller forsigtigt ryste maden let i friturekurven.

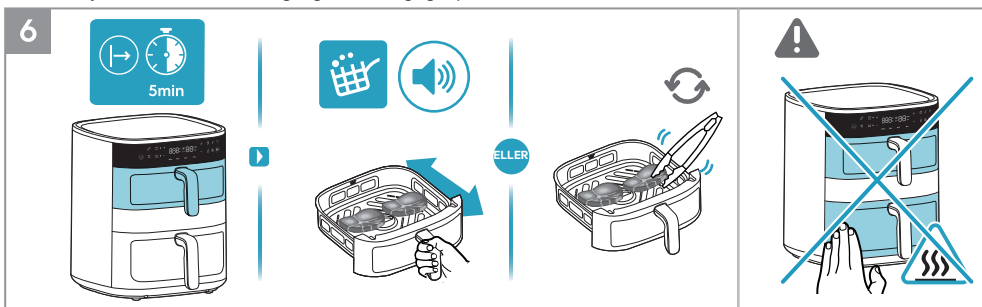

6. For det andet vil den øverste kurv med kortere indstillingstid begynde at koge. Når ikonet "Shake Reminder" (Påmindelse om at ryste) lyser og bipper under tilberedningen, skal du bruge varmebestandigt værktøj til at vende maden én gang eller forsigtigt ryste maden let i friturekurven.

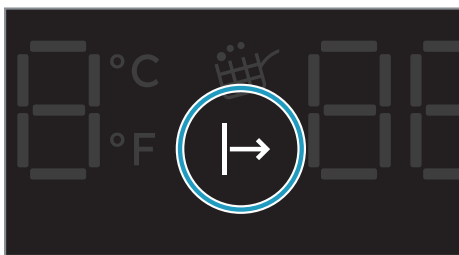

Indikator for venter på at lave mad

Når "Sync end function" (Synkroniser slut-funktion) er aktiveret, vil kurven med kortere tilberedningstid vente med at starte tilberedningen, indtil kurven med længere tilberedningstid har været i gang i et stykke tid, så begge kurve kan afslutte tilberedningen samtidig. I denne periode vil "Indikator for venter på at lave mad" lyse, indtil tilberedningen begynder.



7. Ved afslutningen af tilberedningstiden afgiver apparatet et bip. Tag stikket ud af stikkontakten efter brug.

Rengøring

1

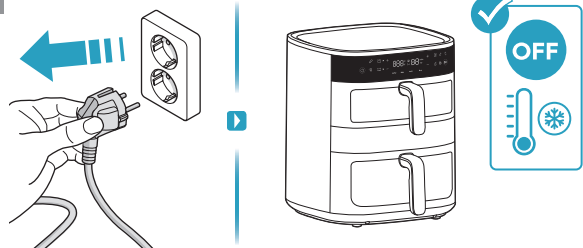

2



1. Tag altid stikket ud af stikkontakten, og vent med at rengøre apparatet, til det er kølet af.
2. Tør apparatets yderside af med en blød klud.

3

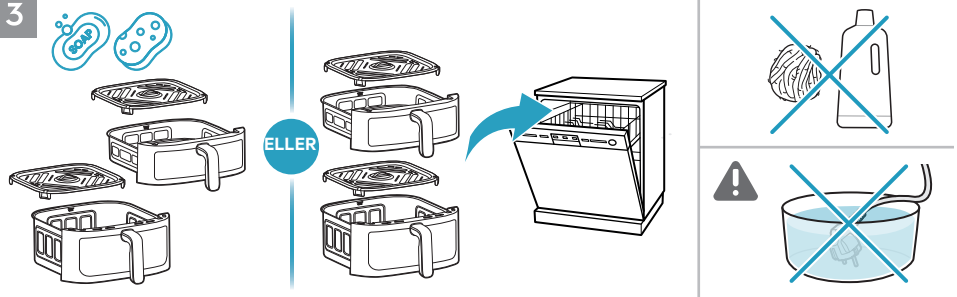

3. Rengør pande og rist med varmt vand og opvaskemiddel, eller sæt dem i opvaskemaskinen.

⚠BEMÆRK: Undgå at bruge slibende rengøringsmidler eller metalredskaber for at beskytte non-stick-belægningen.

FORSIGTIG: Nedsæk aldrig produktet, dets ledning eller stik i vand eller andre væsker.

4

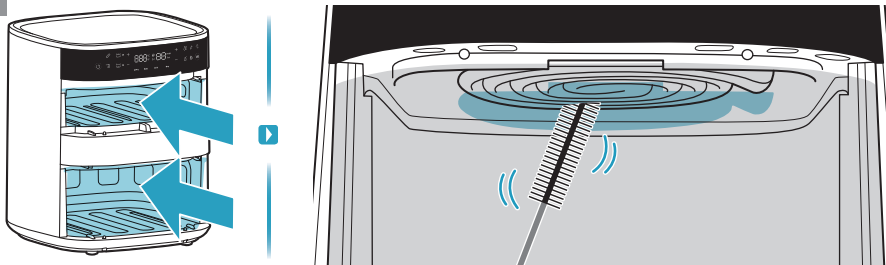

























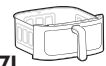













4. Rengør varmeelementet med en rengøringsbørste.





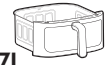















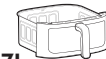

BEMÆRK: Sørg for, at apparatet er helt afkølet, før du rengør varmeelementet.

GB
BG
DE
ES
FR
GR
IT
PT
NL
CA
SE
FI
DK
NO
HU
AR

Guide til madlavning

							
AirFry	7mm/10mm 	 4L	400g	180 °C	18min		
		 7L	400g	180 °C	18min		
AirFry		 4L	400g	170 °C	8min		
		 7L	400g	170 °C	10min		
AirFry		 4L	400g/2stk	140 °C	15min		
		 7L	400g/2stk	140 °C	15min		
AirFry		 4L	1000g/8stk	180 °C	28min		
		 7L	1000g/8stk	180 °C	28min		
AirFry		 4L	400g/2stk	200 °C	10min		
		 7L	400g/2stk	200 °C	10min		
AirFry		 4L	220g/6tommer	160 °C	12min		
		 7L	220g/6tommer	160 °C	14min		

- GB
- BG
- DE
- ES
- FR
- GR
- IT
- PT
- NL
- CA
- SE
- FI
- DK**
- NO
- HU
- AR

Recipe							
AirFry		 7L	1200g	180 °C	55min		
AirFry		 7L	400g/9stk	160 °C	20min		
Grill		 4L	180g/4stk	180 °C	8min		
		 7L	180g/4stk	180 °C	9min		
Dry		 4L	180g	80 °C	3timer		
		 7L	180g	80 °C	3timer		
Dry		 4L	200g	80 °C	3timer		
		 7L	200g	80 °C	3timer		

GB
BG
DE
ES
FR
GR
IT
PT
NL
CA
SE
FI
DK
NO
HU
AR

Hvad skal man gøre hvis...

Problem	Kontroller om...
Du kan ikke aktivere eller betjene apparatet.	<ul style="list-style-type: none">• Apparatet er korrekt tilsluttet en elektrisk forsyning.• Kurvene er i den rigtige position. Sørg for, at de er skubbet helt ind i apparatet for at aktivere den elektriske forsyning.• Tilberedningstiden er indstillet.
Du kan ikke skubbe kurven ind i apparatet.	<ul style="list-style-type: none">• Kurven er fyldt over sin maksimale kapacitet.• Kurven er placeret korrekt. Den skal klikke, når du sætter den i enheden.• Der er en genstand under kurven, som er en forhindring for at lukke den ordentligt.
Der kommer hvid røg ud af apparatet.	<ul style="list-style-type: none">• Den mad, du laver, er for fedtet.• Kurven, risten og varmeelementet er rene.
Displayet viser E1	<ul style="list-style-type: none">• Åbent kredsløb i den øverste kurven.
Displayet viser E2	<ul style="list-style-type: none">• Kortslutning i den øverste kurven.
Displayet viser E3	<ul style="list-style-type: none">• Åbent kredsløb i den nederste kurven.
Displayet viser E4	<ul style="list-style-type: none">• Kortslutning i den nederste kurven.
Displayet viser E5	<ul style="list-style-type: none">• Kommunikationsfejl i kontrol-PCBA.
Displayet viser E6	<ul style="list-style-type: none">• Power PCBA-kommunikationsfejl.

* Hvis displayet viser fejlkoder, skal apparatet repareres af et servicecenter.

Tekniske data

Produkt	Model
Model	AAFD11B
Spænding (V~)	220 V ~ 240 V
Effekt (W)	2700 W
Frekvens (Hz)	50 ~ 60 Hz
Kapacitet	4 L + 7 L

GB

BG

DE

ES

FR

GR

IT

PT

NL

CA

SE

FI

DK

NO

HU

AR



Bruksanvisning

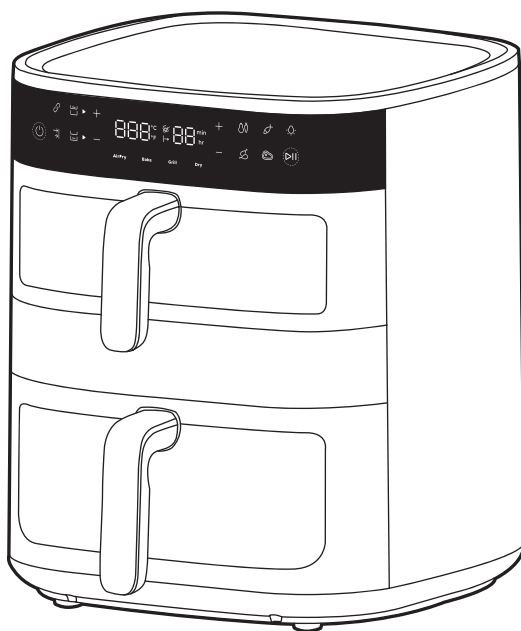

800 dobbel airfryer

Generell oversikt

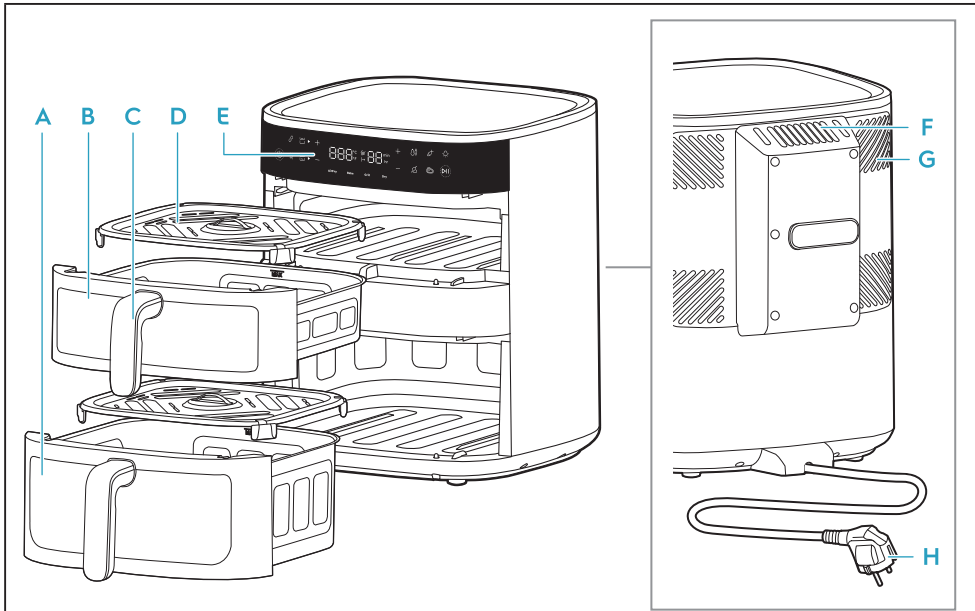

- | | | | |
|-------------------------|----------------------|------------------------|-----------------------|
| A Bunnkurv (7 l) | C Kurvhåndtak | E Kontrollpanel | G Kjølesystem |
| B Toppkurv (4 l) | D Risten | F Luftutløp | H Hovedledning |

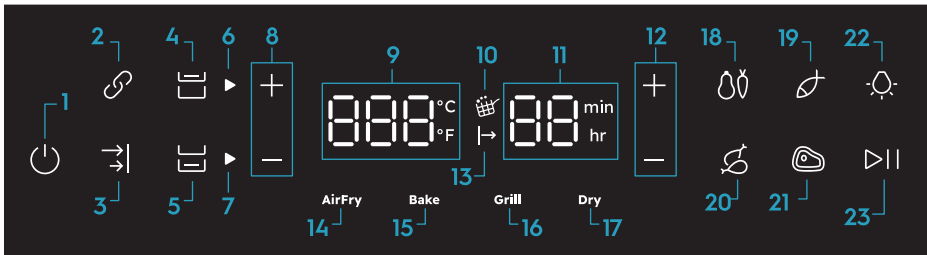

- | | | | |
|----------------------------------|---|---------------------|-----------------|
| 1. På/Av | 8. Temperaturstyring | 14. AirFry-funksjon | 20. Kylling |
| 2. Koblingsfunksjon | 9. Temperaturindikator (40–200 °C) | 15. Stekefunksjon | 21. Biff |
| 3. Slutt synkroniseringsfunksjon | 10. Ristepåminnelse | 16. Grillfunksjon | 22. Lysstyring |
| 4. Toppkurvstyring | 11. Tidsindikator (AirFry: 1-99 minutter, dehydrere: 1-5 timer) | 17. Tørkefunksjon | 23. Start/Pause |
| 5. Bunnkurvstyring | 12. Tidsstyring | 18. Grønnsaker | |
| 6. Toppkurvindikator | 13. Venter på tilberedning | 19. Fisk | |
| 7. Bunnkurvindikator | | | |

Før første bruk

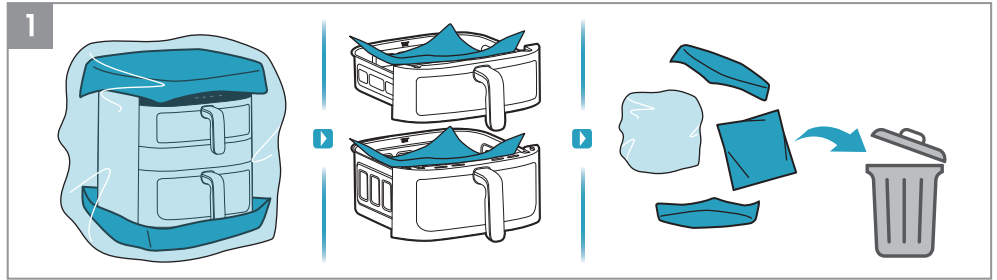

1. Fjern all emballasje og beskyttelsesmateriale.

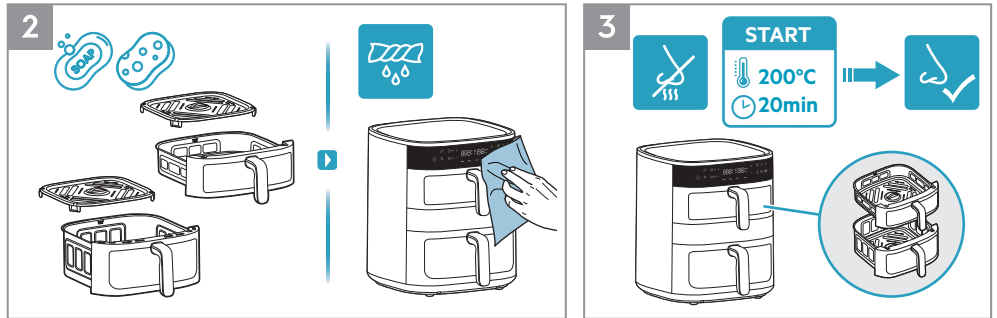



2. Rengjør pannen og risten med varmt vann og oppvaskmiddel. Tørk av apparatet innvendig og utvendig med en myk klut.

3. Det er normalt at en ny enhet avgir en lukt de første gangene den brukes. Kjør den tomme frityrkokeren ved 200 °C i 20 minutter før første gangs bruk for å unngå dette.

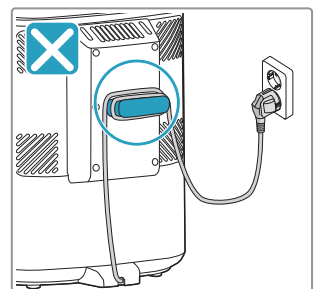
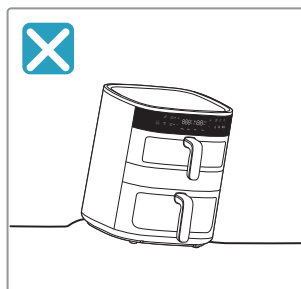
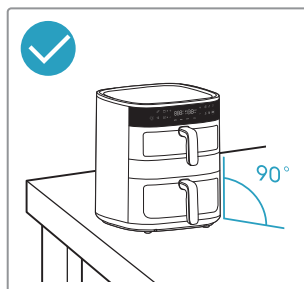
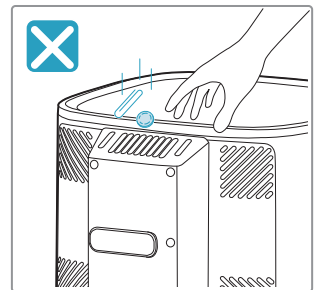
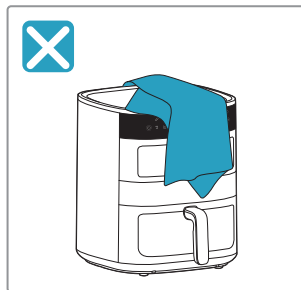
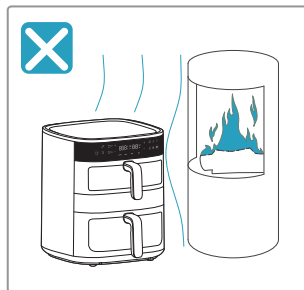



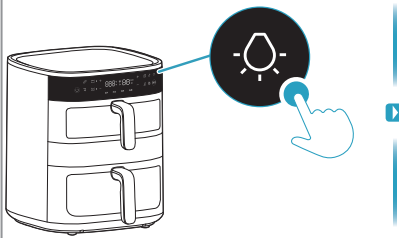
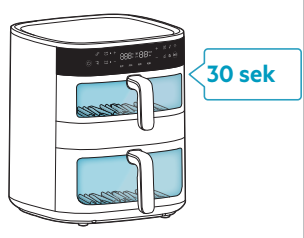

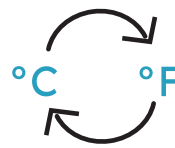



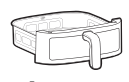

! Sikkerhetsforholdsregler



Lysstyring og temperaturskalaomregning





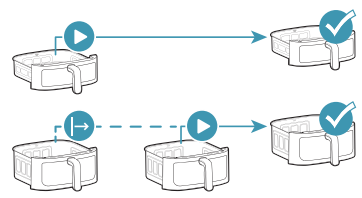





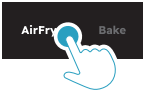



 <p>Lysstyring</p>		 <p>30 sek</p>
<p>°C/°F</p> <p>Temperaturskalaomregning</p>	 <p>30 sek</p>	

Kurvvalg

	 <p>4l</p>	 <p>7l</p>	
 <p>Toppkurv</p>			
 <p>Bunnkurv</p>			
 <p>Koblingsfunksjon</p>			
 <p>Sluttsynkroniseringsfunksjon</p>			

- GB
- BG
- DE
- ES
- FR
- GR
- IT
- PT
- NL
- CA
- SE
- FI
- DK
- NO**
- HU
- AR

Forhåndsinnstilte funksjoner

 Air Fry					
Air Fry	180°C	15min	60-200°C	1-99min	
	170°C	10min	60-200°C	1-99min	
	140°C	15min	60-200°C	1-99min	
	180°C	30min	60-200°C	1-99min	
	200°C	10min	60-200°C	1-99min	
Bake	170°C	15min	60-200°C	1-99min	
Grill	200°C	5min	60-200°C	1-99min	
Dry	80°C	5t	40-80°C	1-5t	

GB
BG
DE
ES
FR
GR
IT
PT
NL
CA
SE
FI
DK
NO
HU
AR

Før tilberedning

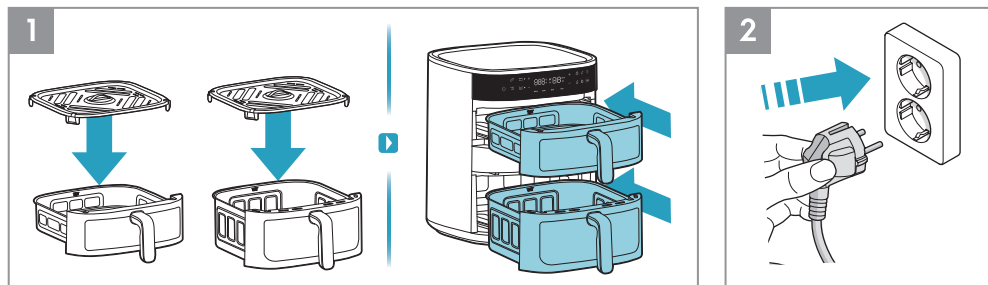

1. Før hver tilberedning må du plassere risten i kurven (den varmebestandige silikonfoten på risten trenger ikke fjernes) og skyve kurven helt inn i apparatet.
2. Sett strømpluggen inn i strømuttaket.

Hvordan bruke - Enkel kurv

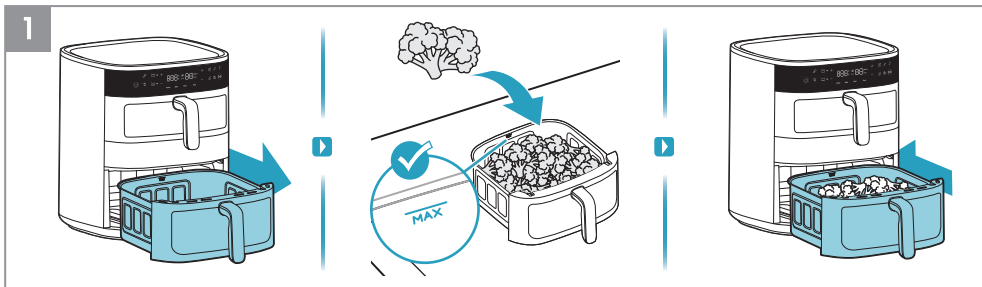

1. Trekk ut en kurv og plasser den på et stabilt underlag, legg maten i kurven og følg kapasitetsangivelsen "MAX". Skyv deretter kurven med maten helt tilbake inn i apparatet.

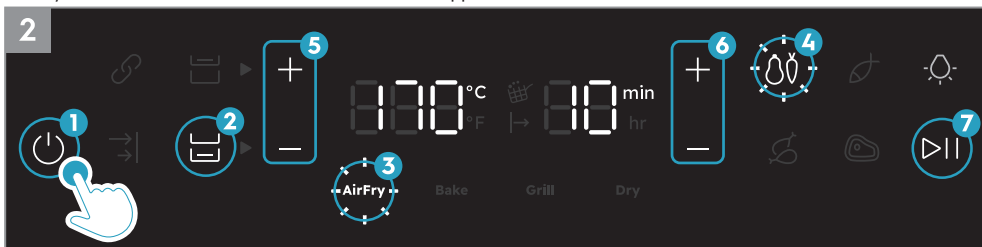

2. Trykk på Av/På-knappen. Velg først kurven med mat. Velg deretter ønsket tilberedningsmetode, for eksempel AirFry-funksjonen. Juster tid og temperatur etter smak, eller velg en av de forhåndsinnstilte oppskriftene, for eksempel "Grønnsaker". Til slutt trykker du på Start/Pause-knappen.

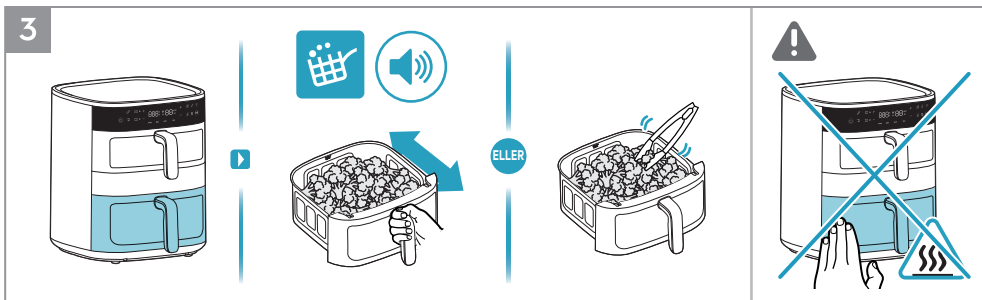

3. Når ikonet "Ristepåminnelse" lyser og piper under tilberedningen, bruk varmebestandige redskaper til å snu maten én gang eller rist forsiktig på maten i stekekurven.

⚠ FORSIKTIG: Ikke rist stekekurven kraftig for å forhindre at maten spruter og forårsaker brannskader.

⚠ FORSIKTIG: Vær forsiktig med varme overflater når apparatet er i bruk.

Ristepåminnelse

"Ristepåminnelse" aktiveres under AirFry-funksjonen og forhåndsinnstilte oppskrifter, for eksempel grønnsaker, fisk, kyllinglår og biff.

Når det er på tide å riste eller snu maten, vil "Ristepåminnelse"-ikonet lyse og blinke i ett minutt, mens en pipelyd gjentas tre ganger.

"Ristepåminnelsen" er ikke obligatorisk, og tilberedningen fortsetter som vanlig selv om maten ikke blir snudd eller ristet.

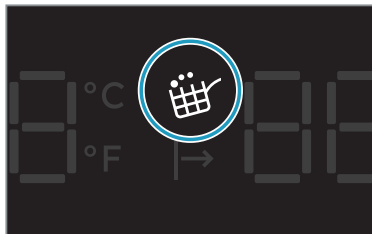

GB
BG
DE
ES
FR
GR
IT
PT
NL
CA
SE
FI
DK
NO
HU
AR

4

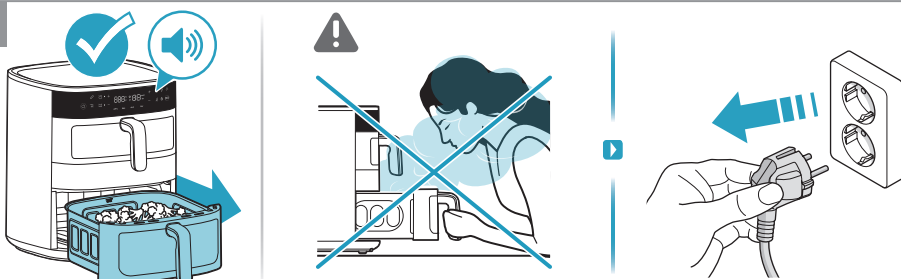

4. Når tilberedningstiden er over, vil apparatet avgi en pipelyd. Fjern kurven forsiktig og sett den på en varmebestandig overflate. Koble apparatet fra strømmettet etter bruk.

⚠ **FORSIKTIG:** Det kan komme varm damp ut av kurven når den åpnes midt i eller på slutten av tilberedningen. Sørg for at ansiktet, armene og hendene er unna dampen når du åpner den.

Hvordan bruke - Top- + Bunnkurv

1

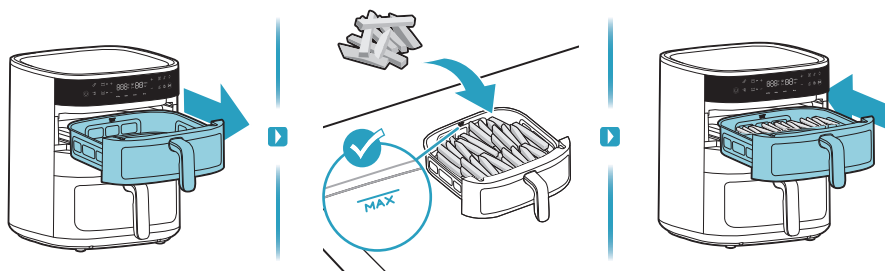

1. Først trekker du ut toppkurven og legger maten i kurven, for eksempel pommes frites.

2

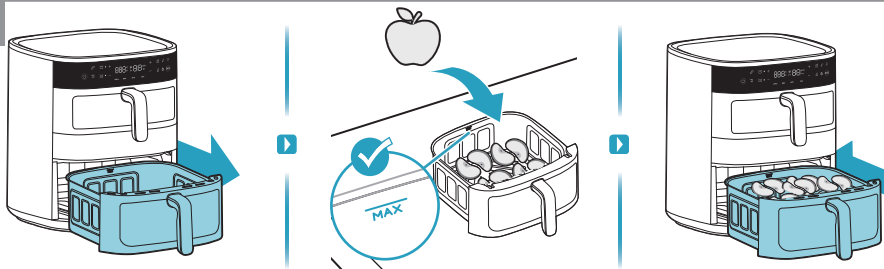

2. Deretter trekker du ut den bunnkurven og legger maten i kurven, for eksempel epleskiver.

3



3. Trykk på Av/På-knappen. Velg først toppkurven. Velg deretter ønsket tilberedningsmetode, for eksempel AirFry-funksjonen. Juster tid og temperatur etter smak, eller velg en av de forhåndsinnstilte oppskriftene, for eksempel "Grønnsaker". Til slutt trykker du på Start/Pause-knappen.



4. Velg deretter bunnkurven. Velg deretter ønsket tilberedningsmetode, for eksempel tørkefunksjonen. Juster tid og temperatur etter smak. Til slutt trykker du på Start/Pause-knappen.

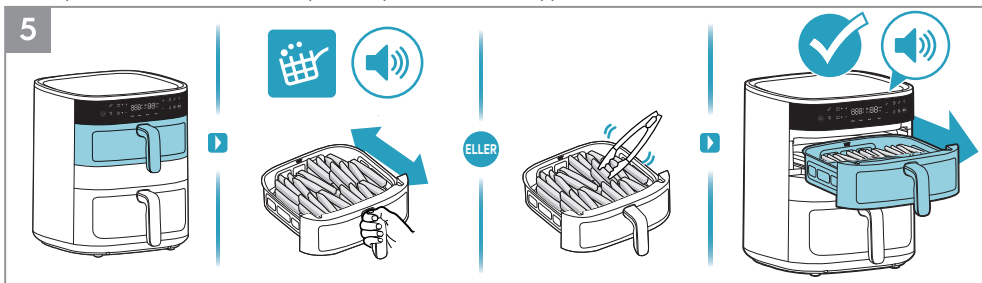

5. Når ikonet "Ristepåminnelse" lyser og piper under tilberedningen, bruk varmebestandige redskaper til å snu maten én gang eller rist forsiktig på maten i stekekurven. Når koketiden for toppkurven er over, vil apparatet avgi en pipelyd.

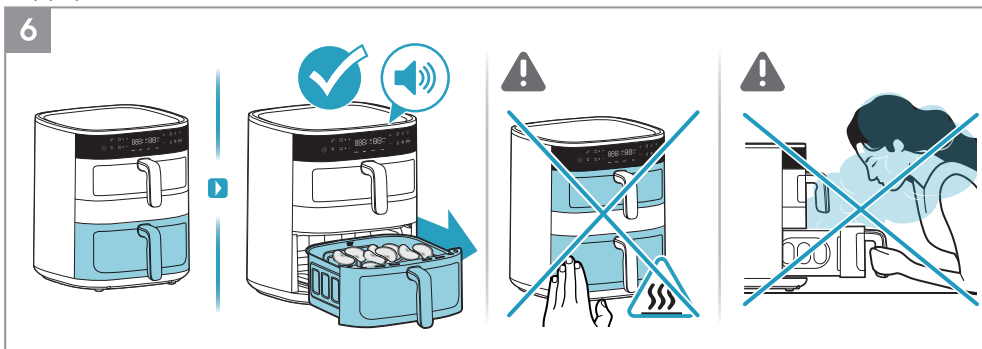

6. Når koketiden for bunnkurven er over, vil apparatet avgi en pipelyd.

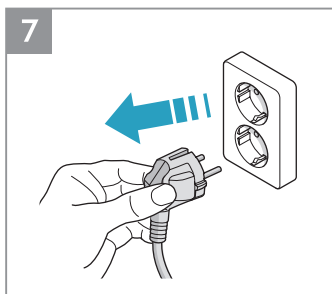

7. Koble apparatet fra strømmettet etter bruk.

GB
BG
DE
ES
FR
GR
IT
PT
NL
CA
SE
FI
DK
NO
HU
AR

Hvordan bruke - Koblingsfunksjon

1

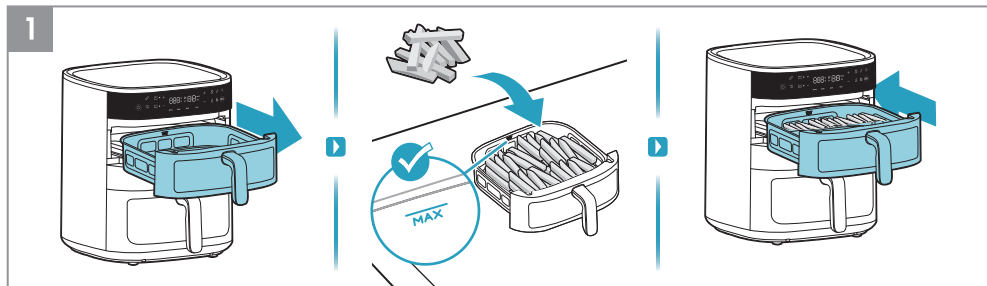

1. Først trekker du ut toppkurven og legger maten i kurven, for eksempel pommes frites.

2

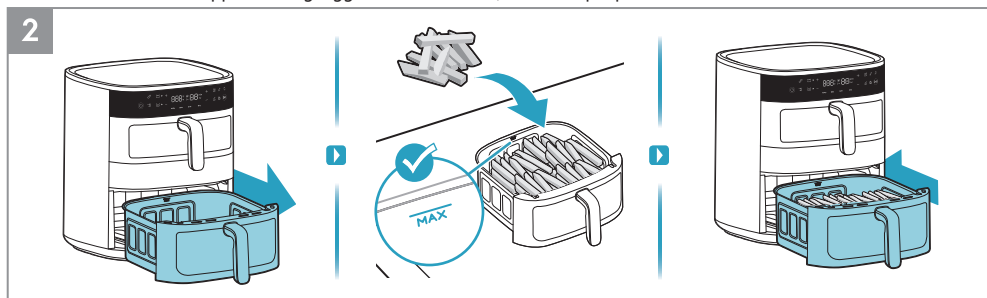

2. Deretter trekker du ut bunnkurven og legger maten i kurven, for eksempel pommes frites.

3



3. Trykk på Av/På-knappen. Velg først koblingsfunksjonen. Velg deretter ønsket tilberedningsmetode, for eksempel AirFry-funksjonen. Juster tid og temperatur etter smak, eller velg en av de forhåndsinnstilte oppskriftene. Til slutt trykker du på Start/Pause-knappen.

4

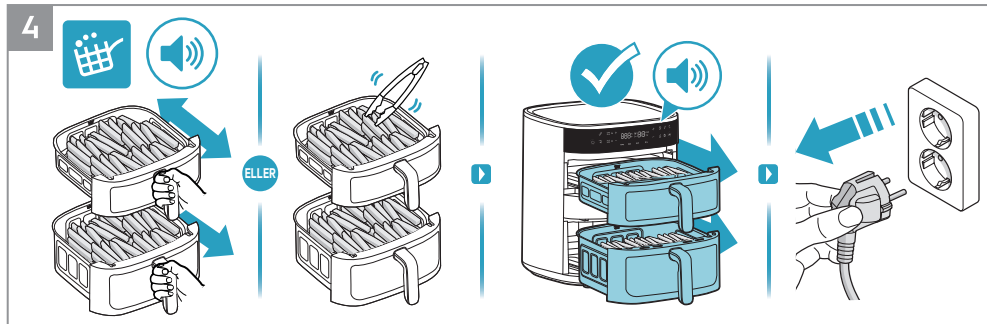

4. Når ikonet "Ristepåminnelse" lyser og piper under tilberedningen, bruk varmebestandige redskaper til å snu maten én gang eller rist forsiktig på maten i stekekurven. Når tilberedningstiden er over, vil apparatet avgi en pipelyd. Koble apparatet fra strømmettet etter bruk.

GB
BG
DE
ES
FR
GR
IT
PT
NL
CA
SE
FI
DK
NO
HU
AR

Hvordan bruke - Sluttsynkroniseringsfunksjon

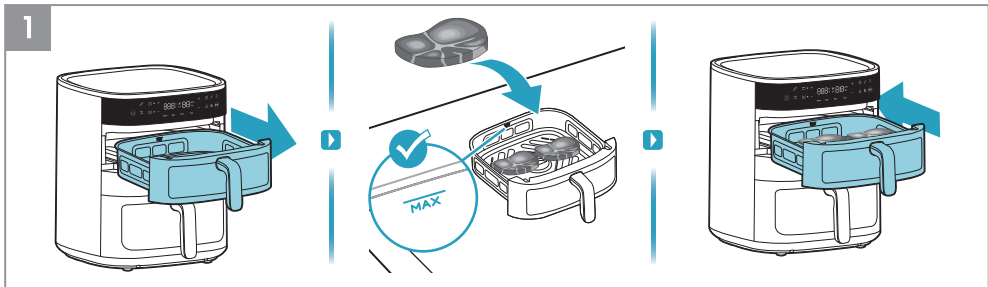

1. Først trekker du ut toppkurven og legger maten i kurven, for eksempel biff.

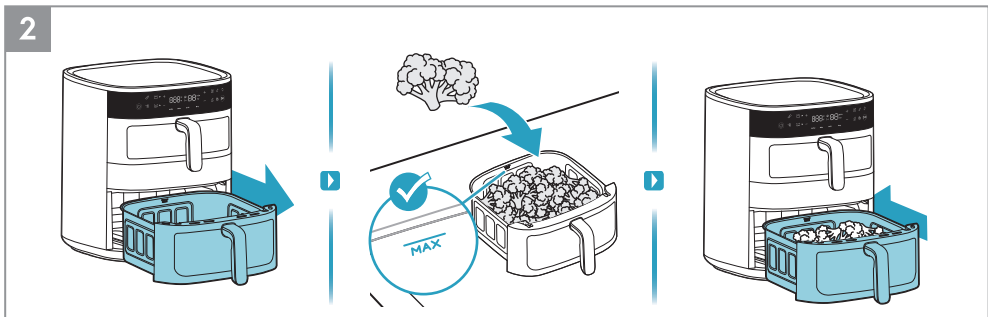

2. Deretter trekker du ut bunnkurven og legger maten i kurven, for eksempel brokkoli.

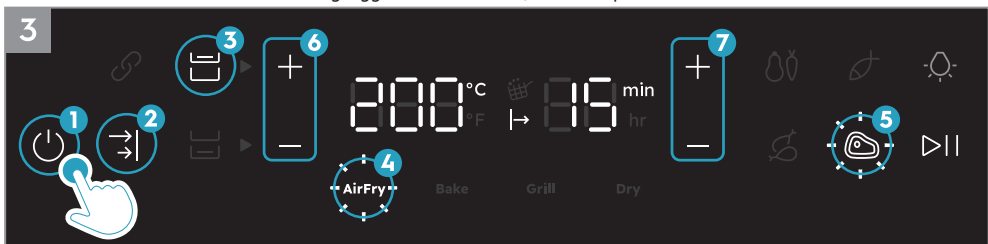

3. Trykk på Av/På-knappen. Velg sluttsynkroniseringsfunksjonen. Velg først toppkurven, og velg deretter ønsket tilberedningsmetode, for eksempel AirFry-funksjonen. Juster tid og temperatur etter smak, eller velg en av de forhåndsinnstilte oppskriftene, for eksempel "Biff".

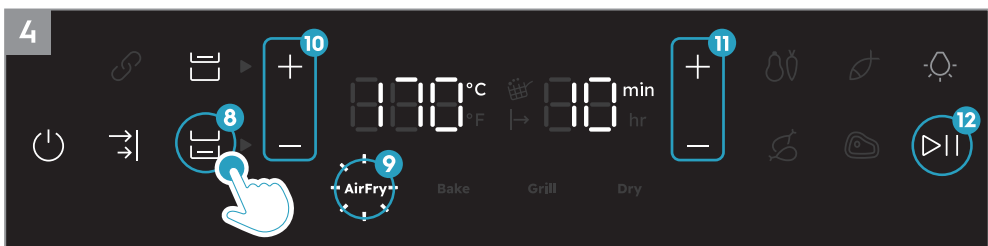

4. Velg deretter bunnkurven, velg ønsket tilberedningsmetode, for eksempel AirFry-funksjonen. Juster tid og temperatur etter smak, eller velg en av de forhåndsinnstilte oppskriftene. Til slutt trykker du på Start/Pause-knappen.

5

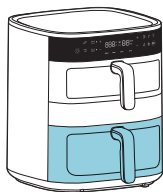

ELLER



5. Tilberedning av bunnkurven med lengre innstillingstid vil prioriteres først. Når ikonet "Ristepåminnelse" lyser og piper under tilberedningen, bruk varmebestandige redskaper til å snu maten én gang eller rist forsiktig på maten i stekekurven.

6

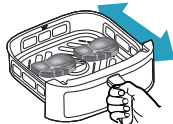
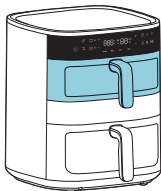

ELLER

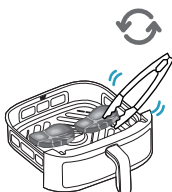

6. Deretter begynner tilberedningen av toppkurven med kortere innstillingstid. Når ikonet "Ristepåminnelse" lyser og piper under tilberedningen, bruk varmebestandige redskaper til å snu maten én gang eller rist forsiktig på maten i stekekurven.

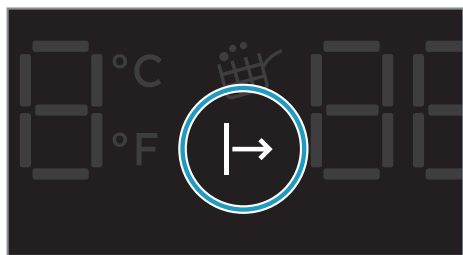

Indikator for venting på tilberedning

Når "Sluttsynkroniseringsfunksjonen" er aktivert, vil kurven med kortere tilberedningstid vente med tilberedningen til kurven med lengre tilberedningstid har tilberedt en stund, slik at begge kurvene kan avslutte tilberedningen samtidig. I denne perioden vil "Indikator for venting på tilberedning" lyse til tilberedningen starter.

7

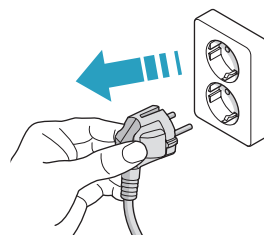
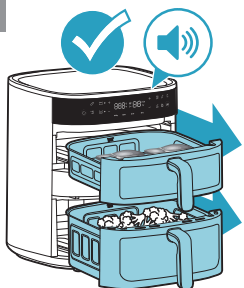

7. Når tilberedningstiden er over, vil apparatet avgi en pipelyd. Koble apparatet fra strømmettet etter bruk.

Rengjøring

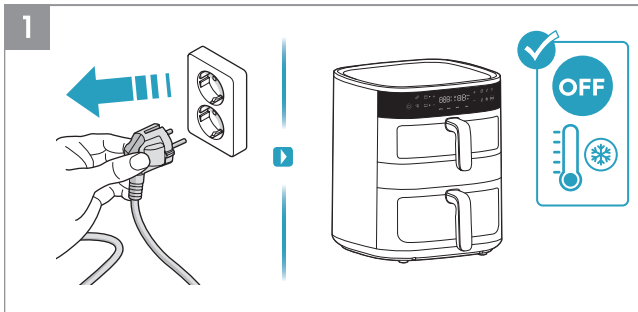

1. Koble alltid apparatet fra strømnettet og vent til det er avkjølt før du rengjør det.
2. Tørk av utsiden av apparatet med en myk klut.

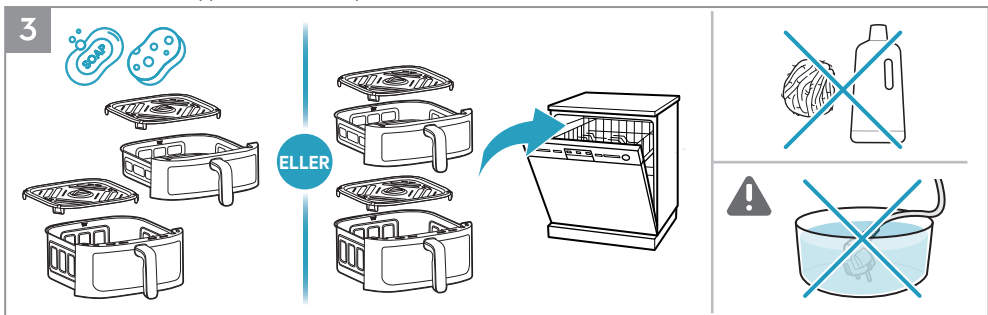
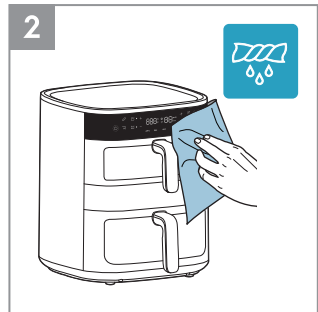

3. Rengjør pannen og risten med varmt vann og oppvaskmiddel, eller legg dem i oppvaskmaskinen.

▲MERK: Unngå å bruke slipende rengjøringsmidler eller metallverktøy for å beskytte non-stick-belegget.

FORSIKTIG: Produktets ledning eller støpsel må aldri dyppes i vann eller andre væsker.

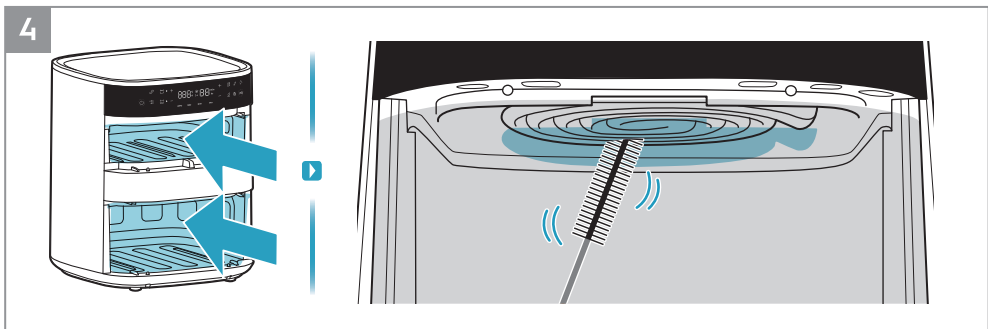

4. Rengjør varmeelementet med en rengjøringsbørste.

MERK: Sørg for at apparatet er helt avkjølt før du rengjør varmeelementet.

GB

BG

DE

ES

FR

GR

IT

PT

NL

CA

SE

FI































DK

NO

























HU

AR

Tilberedningsguide

							
AirFry 		4l	400g	180 °C	18min		
		7l	400g	180 °C	18min		
AirFry 		4l	400g	170 °C	8min		
		7l	400g	170 °C	10min		
AirFry 		4l	400g/2stk.	140 °C	15min		
		7l	400g/2stk.	140 °C	15min		
AirFry 		4l	1000g/8stk.	180 °C	28min		
		7l	1000g/8stk.	180 °C	28min		
AirFry 		4l	400g/2stk.	200 °C	10min		
		7l	400g/2stk.	200 °C	10min		
AirFry 		4l	220g/15 cm	160 °C	12min		
		7l	220g/15 cm	160 °C	14min		

GB
BG
DE
ES
FR
GR
IT
PT
NL
CA
SE
FI
DK
NO
HU
AR

							
AirFry		 7l	1200g	180 °C	55min		
AirFry		 7l	400g/9stk.	160 °C	20min		
Grill		 4l	180g/4stk.	180 °C	8min		
		 7l	180g/4stk.	180 °C	9min		
Dry		 4l	180g	80 °C	3t		
		 7l	180g	80 °C	3t		
Dry		 4l	200g	80 °C	3t		
		 7l	200g	80 °C	3t		

- GB
- BG
- DE
- ES
- FR
- GR
- IT
- PT
- NL
- CA
- SE
- FI
- DK
- NO**
- HU
- AR

Hva gjør du hvis ...

Problem	Sjekk om ...
Du ikke kan aktivere eller bruke apparatet.	<ul style="list-style-type: none">• Apparatet er riktig koblet til strømforsyningen.• Kurvene er i riktig posisjon. Sørg for at de er helt presset inn i apparatet for å aktivere strømforsyningen.• Tilberedningstiden er innstilt.
Du klarer ikke å skyve kurven inn i apparatet.	<ul style="list-style-type: none">• Kurven er fylt over sin maksimale kapasitet.• Kurven er plassert riktig. Den må klikke på plass når du setter den inn i enheten.• Det er et objekt under kurven som hindrer den i å lukkes ordentlig.
Det kommer hvit røyk ut av apparatet.	<ul style="list-style-type: none">• Maten du lager er for fet.• Kurven, risten og varmeelementet er rene.
Displayet viser E1	<ul style="list-style-type: none">• Åpen krets i toppkurven.
Displayet viser E2	<ul style="list-style-type: none">• Kortslutning i toppkurven.
Displayet viser E3	<ul style="list-style-type: none">• Åpen krets i bunnkurven.
Displayet viser E4	<ul style="list-style-type: none">• Kortslutning i bunnkurven.
Displayet viser E5	<ul style="list-style-type: none">• Kontroller-PCBA-kommunikasjonsfeil.
Displayet viser E6	<ul style="list-style-type: none">• Strøm-PCBA-kommunikasjonsfeil.

* Hvis displayet viser feilkoder, må apparatet repareres av et servicesenter.

Tekniske data

Produkt	Airfryer
Modell	AAFD11B
Spenning (V~)	220 V ~ 240 V
Effekt (W)	2700 W
Frekvens (Hz)	50 ~ 60 Hz
Kapasitet	4 L + 7 L

GB

BG

DE

ES

FR

GR

IT

PT

NL

CA

SE

FI

DK

NO

HU

AR



Kezelési útmutató

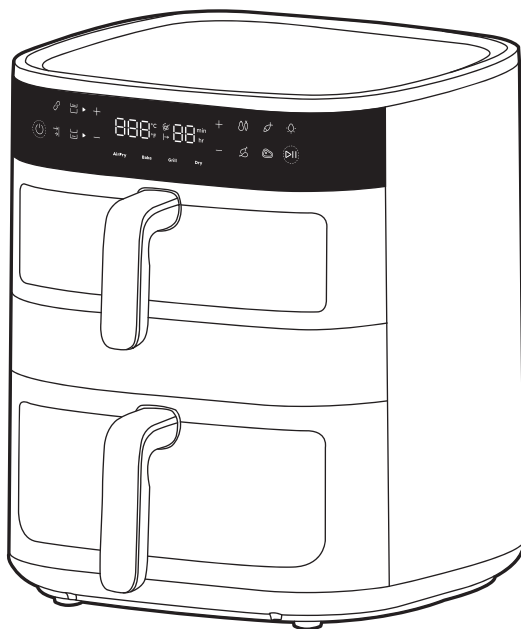

800 dupla forrólevegős sütő

Általános áttekintés

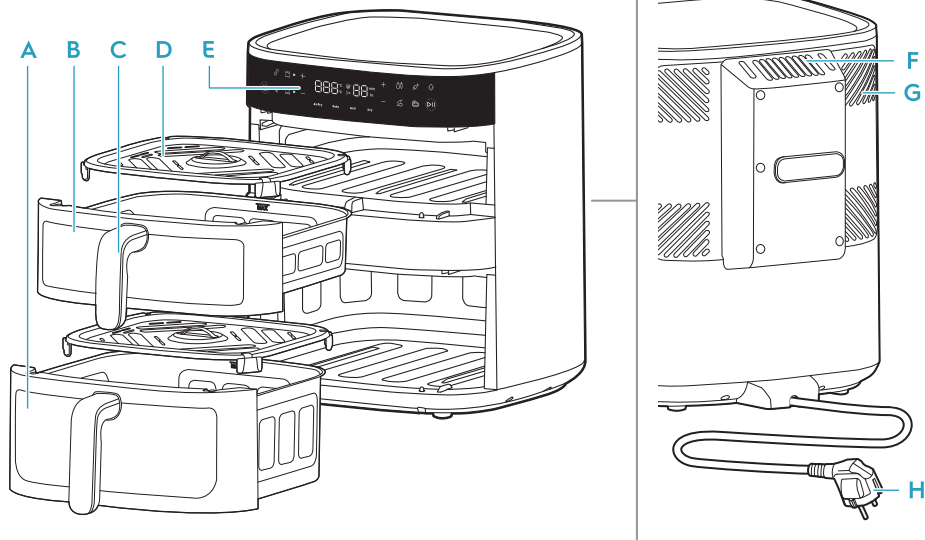

A Alsó kosár (7L)

B Felső kosár (4L)

C Kosárfogó

D Rács

E Kezelőpanel

F Levegőkimenet

G Hűtőrendszer

H Hálózati kábel

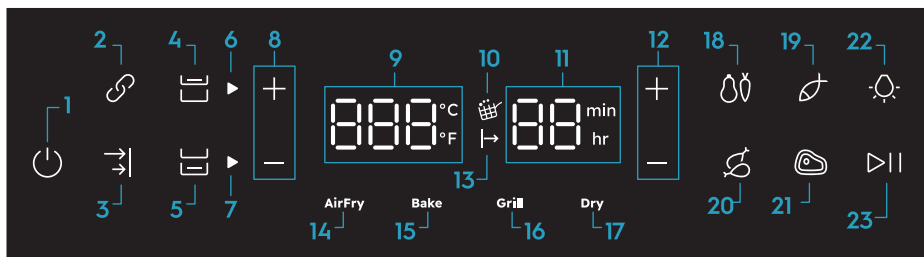

- | | | | |
|------------------------------------|---|--------------------------------|--------------------------|
| 1. Be/ki | 8. Hőmérsékletszabályozás | 13. Sütésre várakozás | 19. Hal |
| 2. Kapcsolat funkció | 9. Hőmérséklet kijelző (40-200 °C) | 14. Forrólevegős sütés funkció | 20. Csirke |
| 3. Szinkronizált befejezés funkció | 10. Rázási emlékeztető | 15. Sütés funkció | 21. Steak |
| 4. Felső kosár érintőgomb | 11. Idő kijelző (Forrólevegős sütés: 1-99 perc, Aszalás: 1-5 óra) | 16. Grillezés funkció | 22. Világítás érintőgomb |
| 5. Alsó kosár érintőgomb | 12. Idő érintőgomb | 17. Aszalás funkció | 23. Működés/szünet |
| 6. Felső kosár kijelző | | 18. Zöldségek | |
| 7. Alsó kosár kijelző | | | |

Az első használat előtt

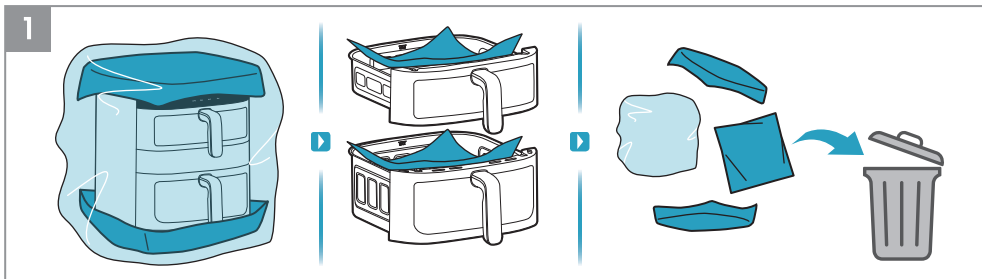

1. Távolítsa el minden csomagoló- és védőanyagot.

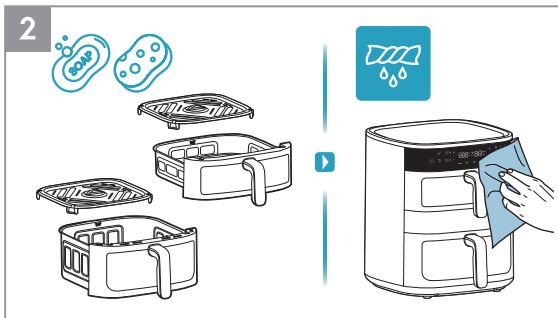

2. Meleg mosogatószeres vízzel tisztítsa meg a serpenyőt és a rácsot. Egy puha kendővel törölje le a készülék belsejét és külsejét.

3. Az egy normális jelenség, hogy egy új készülék szagokat bocsát ki az első néhány alkalommal. Ennek elkerülésére 20 percig 200°C-on működtesse az üres forrólevegős sütőt.

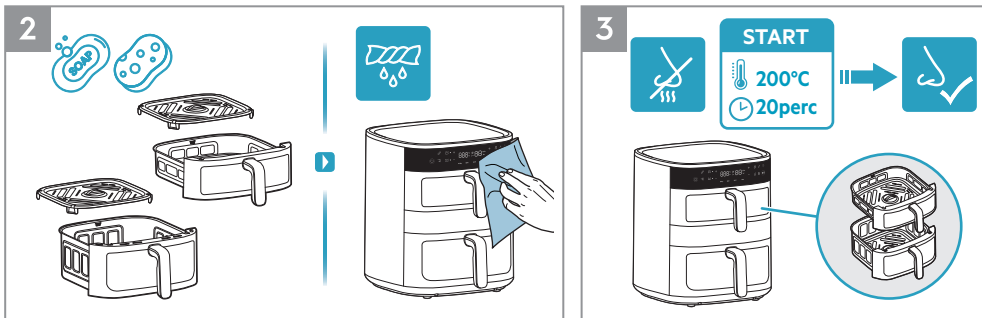

! Biztonsági óvintézkedések

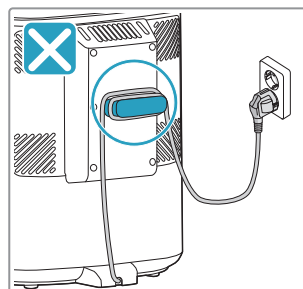
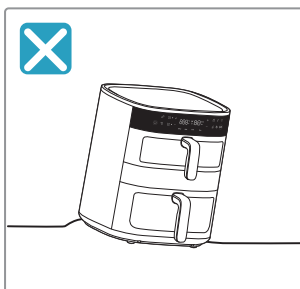
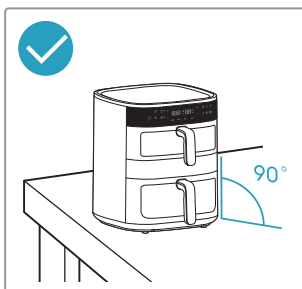
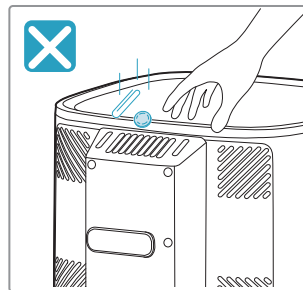
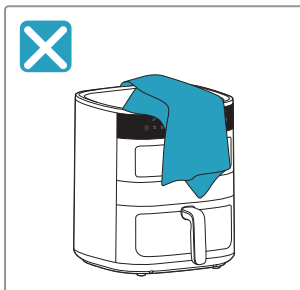
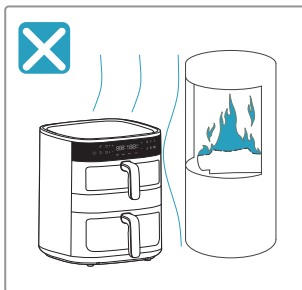

GB

BG

DE

ES

FR

GR

IT

PT

NL

CA

SE

FI



DK

NO





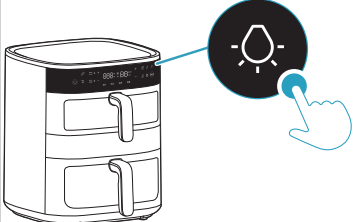
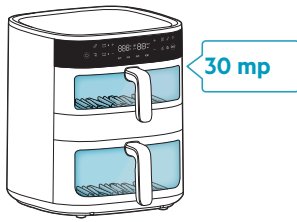
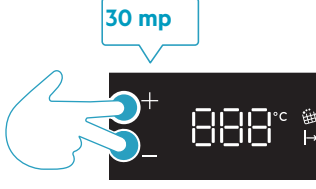





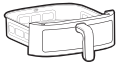

HU

AR

Világítás érintőgomb és hőmérséklet mértékegység váltás





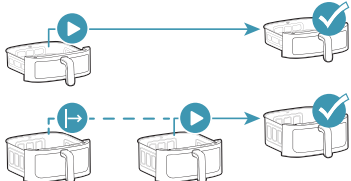









 <p>Világítás érintőgomb</p>		
<p>°C/°F</p> <p>Hőmérséklet mértékegység váltás</p>		

Kosárválasztás

	 <p>4L</p>	 <p>7L</p>	
 <p>Felső kosár</p>			
 <p>Alsó kosár</p>			
 <p>Kapcsolat funkció</p>			
 <p>Szinkronizált befejezés funkció</p>			

EN
BG
DE
ES
FR
GR
IT
PT
NL
CA
SE
FI
DK
NO
HU
AR

Előbeállítás funkció

					
AirFry	180°C	15perc	60~200°C	1~99perc	
	170°C	10perc	60~200°C	1~99perc	
	140°C	15perc	60~200°C	1~99perc	
	180°C	30perc	60~200°C	1~99perc	
	200°C	10perc	60~200°C	1~99perc	
Bake	170°C	15perc	60~200°C	1~99perc	
Grill	200°C	5perc	60~200°C	1~99perc	
Dry	80°C	5óra	40~80°C	1~5óra	

Sütés előtt

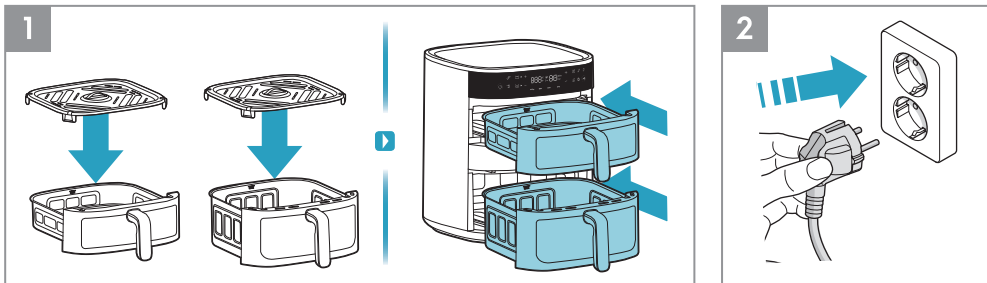

1. Mindegyik sütés előtt tegye a rácsot a kosárba (nem szükséges eltávolítani a rács hőálló szilikon lábtalpat), majd ütközésig nyomja a kosarat a készülékbe.
2. Csatlakoztassa a hálózati kábel csatlakozódugóját egy fali csatlakozóaljzatba.

Használat - egy kosár

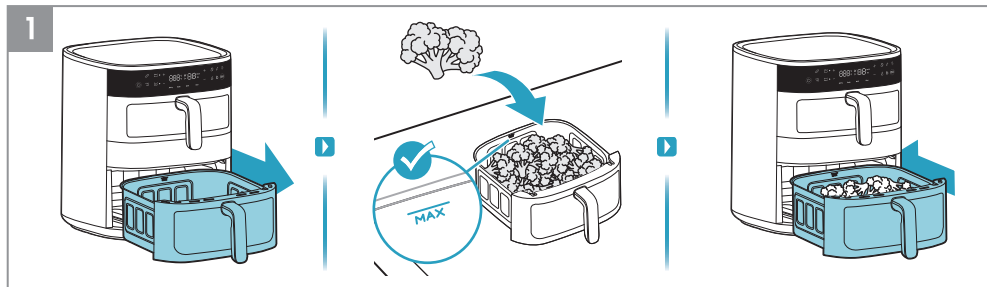

1. Húzza ki az egyik kosarat és tegye egy stabil felületre, "MAX." befogadóképesség jelzésre figyelve tegye az ételt a kosárba. Majd az étellel együtt ütközésig nyomja a kosarat a készülékbe.

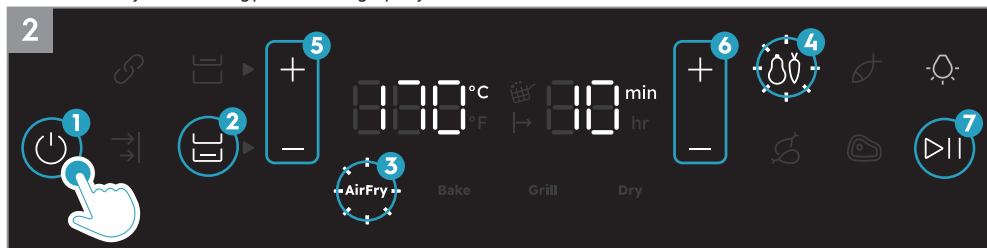

2. Nyomja meg a be/ki gombot. Először válassza ki az ételt tartalmazó kosarat. Majd válassza ki a kívánt elkészítési módszert, pl. forrólevegős sütés funkció. Az ízlésének megfelelően állítsa be az időt és a hőmérsékletet vagy válassza ki az egyik előre beállított receptet, például zöldség. Végül nyomja meg a működés/szünet gombot.

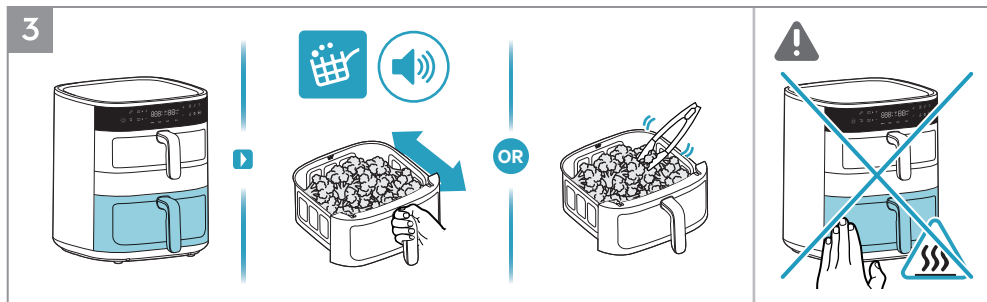

3. Amikor világítani kezd a "Rázási emlékeztető" ikon és sípjelzés hallható a sütési eljárás során, akkor egy hőálló eszköz segítségével fordítsa meg egyszer az ételt vagy körültekintően kissé rázza meg a sütőkosárban lévő ételt.

⚠ **VIGYÁZAT:** Ne rázza erőteljesen a sütőkosarat, hogy elkerülje az étel fröcskölését és égési sérülések okozását.

⚠ **VIGYÁZAT:** A készülék használata során figyeljen a forró felületekre.

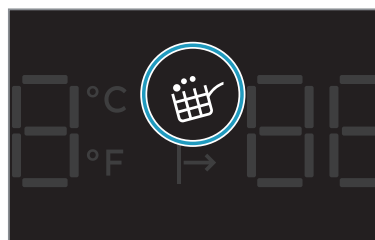

Rázási emlékeztető

A Forrólevegős sütés funkció működése alatt aktíválva van a "Rázási emlékeztető" és az az előre beállított receptek használata, mint pl. Zöldségek, Hal, Csirkecomb és Steak.

Amikor elérkezik az étel rázásának vagy megfordításának az ideje akkor egy percig villog a "Rázási emlékeztető" ikon, továbbá három sípjelzés hallható. Nem feltétlenül szükséges a "Rázási emlékeztető" figyelembevétele, mivel a szokásos módon folytatódik a sütés, még akkor is nem történt meg az étel megfordítása vagy rázása.

EN
BG
DE
ES
FR
GR
IT
PT
NL
CA
SE
FI
DK
NO
HU
AR



4. A sütési idő leteltével egy sípjelzést ad a készülék. Körültekintően vegye ki a kosarat, majd tegye egy hőálló felületre. A készülék használata után bontsa a hálózati csatlakozását.

⚠ **VIGYÁZAT:** Forró gőz léphet ki a kosárból, ha félig kinyitja vagy a sütés végén. A kinyitásakor ügyeljen arra, hogy távol legyen a gőztől az arca, a karja és a keze.

Használat - felső + alsó kosár

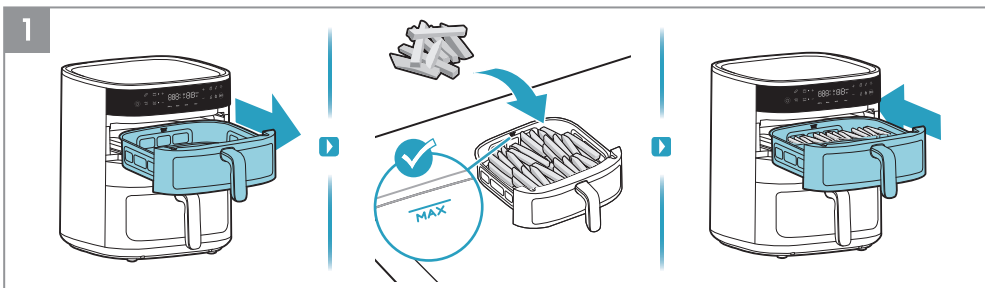

1. Először a felső kosarat húzza ki, tegye az ételt a kosárba, például, sültkrumpli.

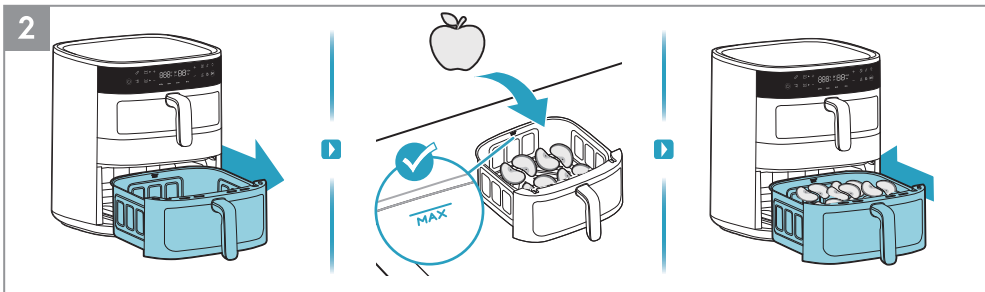

2. Másodszor az alsó kosarat húzza ki, tegye az ételt a kosárba, például, alm szeleteket.



3. Nyomja meg a be/ki gombot. Először a felső kosarat válassza ki. Majd válassza ki a kívánt elkészítés módszert, pl. forrólevegős sütés funkció. Az ízlésének megfelelően állítsa be az időt és a hőmérsékletet vagy válassza ki az egyik előre beállított receptet, például zöldség. Végül nyoma meg a működés/szünet gombot.



4. Másodszor az alsó kosarat válassza ki. Majd válassza ki a kívánt elkészítés módszert, pl. Aszalás funkció. Az ízlésének megfelelően válassza ki a hőmérsékletet és az időt. Végül nyomja meg a működés/szünet gombot.

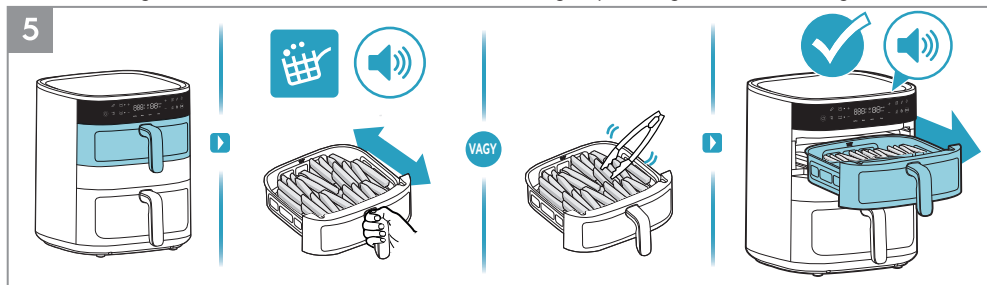

5. Amikor világítani kezd a „Rázási emlékeztető” ikon és sípjelzés hallható a sütési eljárás során, akkor egy hőálló eszköz segítségével fordítsa meg egyszer az ételt vagy körültekintően kissé rázza meg a sütőkosárban lévő ételt. A felső kosár sütési idejének a leteltével egy sípjelzést ad a készülék.

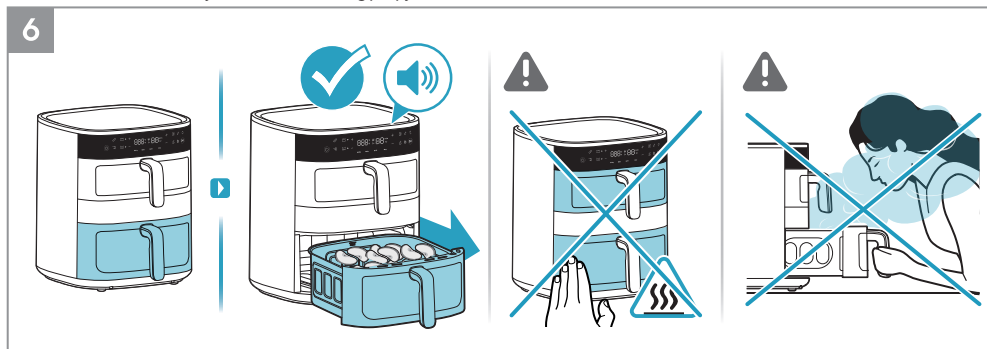

6. Az alsó kosár sütési idejének a leteltével egy sípjelzést ad a készülék.

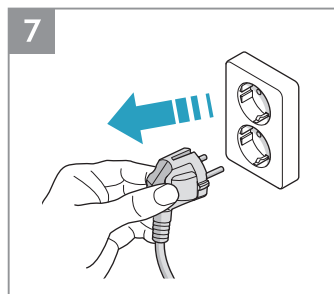

7. A készülék használata után bontsa a hálózati csatlakozását.

Használat - Kapcsolat funkció

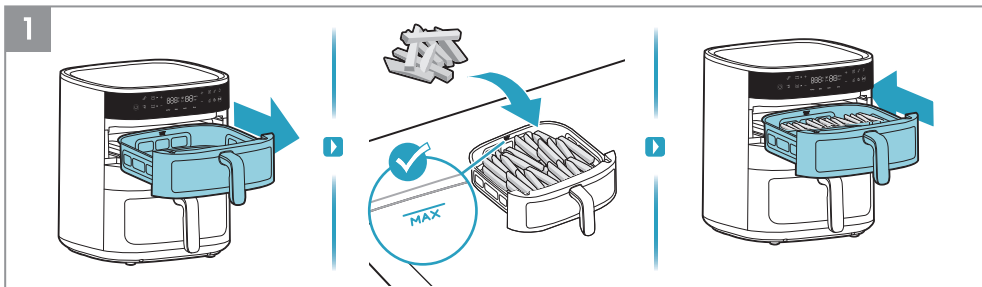

1. Először a felső kosarat húzza ki, tegye az ételt a kosárba, például, sültkrumpli.

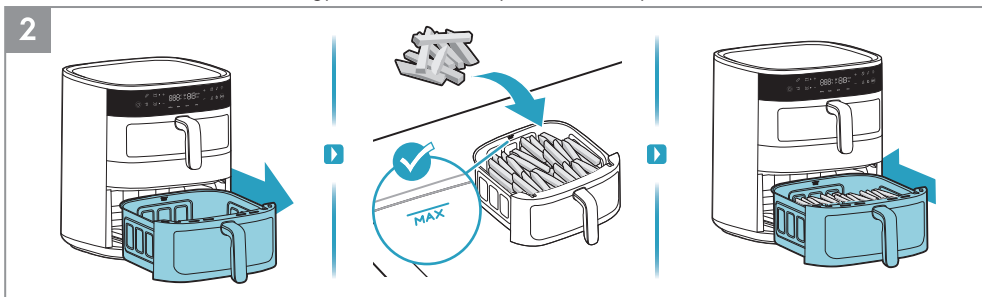

2. Másodszor az alsó kosarat húzza ki, tegye az ételt a kosárba, például, sültkrumpli.



3. Nyomja meg a be/ki gombot. Először válassza ki a Kapcsolat funkciót. Majd válassza ki a kívánt elkészítés módszert, pl. forrólevegős sütés funkciót. Az ízlésének megfelelően állítsa be az időt és a hőmérsékletet vagy válassza ki egyik előre beállított receptet. Végül nyoma meg a működés/szünet gombot.

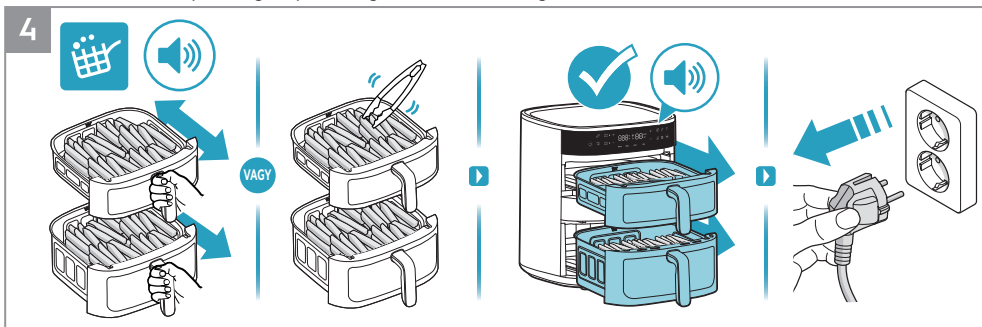

4. Amikor világítani kezd a "Rázási emlékeztető" ikon és sípjelzés hallható a sütési eljárás során, akkor egy hőálló eszköz segítségével fordítsa meg egyszer az ételt vagy körültekintően kissé rázza meg a sütőkosárban lévő ételt. A sütési idő leteltével egy sípjelzést ad a készülék. A készülék használata után bontsa a hálózati csatlakozását.

Használat - Szinkronizált befejezés funkció

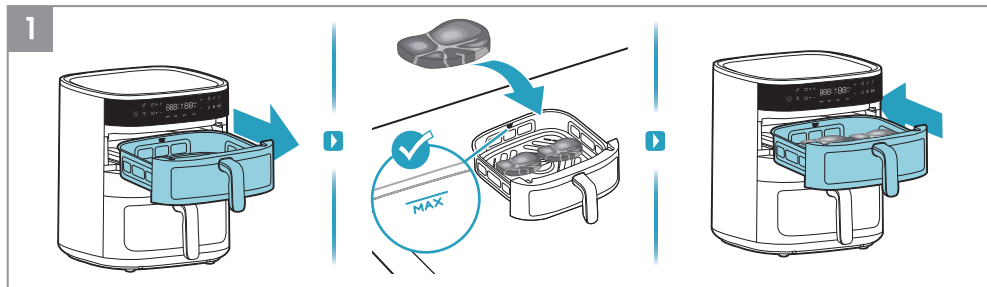

1. Először a felső kosarat húzza ki, tegye az ételt a kosárba, például, steak.

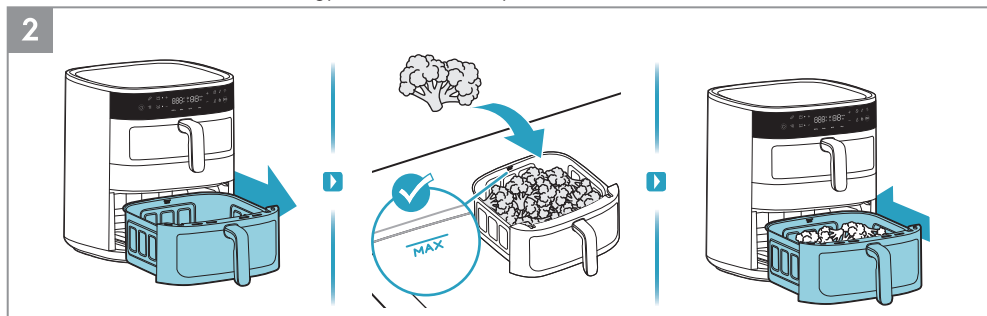

2. Másodszor az alsó kosarat húzza ki, tegye az ételt a kosárba, például, brokkoli.



3. Nyomja meg a be/ki gombot. Válassza ki a Szinkronizált befejezés funkciót. Először válassza ki a felső kosarat, majd válassza ki a kívánt elkészítés módszert, pl. forró levegős sütés funkció. Az izlésének megfelelően állítsa be az időt és a hőmérsékletet vagy válassza ki az egyik előre beállított receptet, például steak.



4. Majd válassza ki az alsó kosarat, válassza ki a kívánt elkészítés módszert, pl. forró levegős sütés funkció. Az izlésének megfelelően állítsa be az időt és a hőmérsékletet vagy válassza ki egyik előre beállított receptet. Végül nyoma meg a működés/szünet gombot.

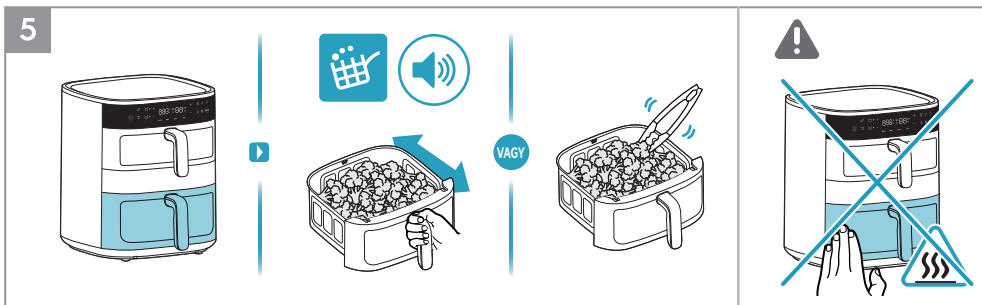

5. Először a hosszabb sütési idejű alsó kosarat részesíti előnybe a sütés során. Amikor világítani kezd a „Rázási emlékeztető” ikon és sípjelzés hallható a sütési eljárás során, akkor egy hőálló eszköz segítségével fordítsa meg egyszer az ételt vagy körültekintően kissé rázza meg a sütőkosárban lévő ételt.

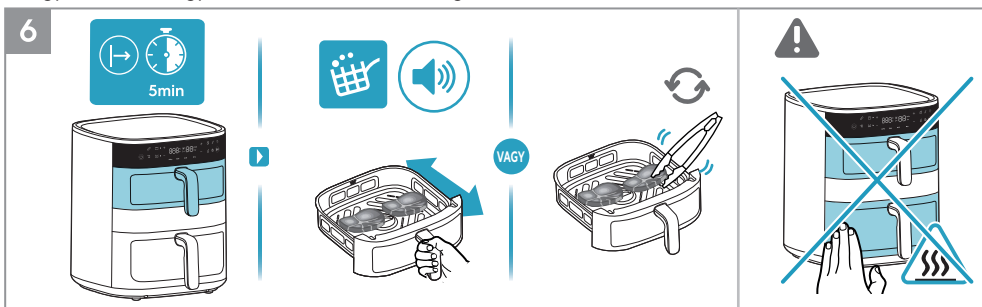

6. Másodszor a rövidebb sütési idejű felső kosár sütését kezdi meg. Amikor világítani kezd a „Rázási emlékeztető” ikon és sípjelzés hallható a sütési eljárás során, akkor egy hőálló eszköz segítségével fordítsa meg egyszer az ételt vagy körültekintően kissé rázza meg a sütőkosárban lévő ételt.

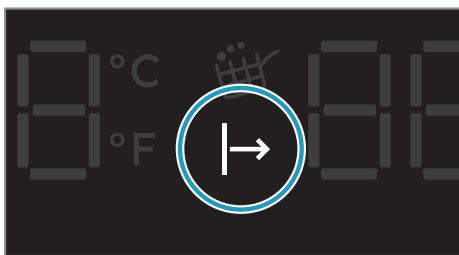

Sütésre várakozás kijelző

Amikor aktiválva van a „Szinkronizált befejezés funkció”, akkor a rövidebb sütési idejű kosár egy ideig vár a hosszabb sütési idejű kosárra, hogy egyszerre fejeződhessen be mindkét kosárban a sütés. Ezen idő alatt a sütés megkezdéséig világít a „sütésre várakozás kijelző”.

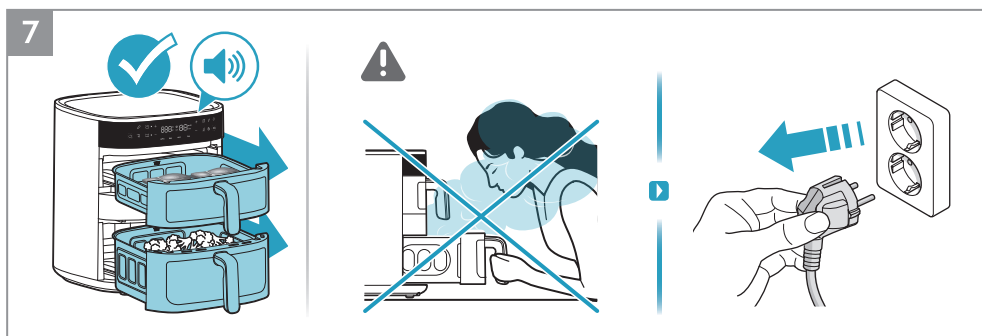

7. A sütési idő leteltével egy sípjelzést ad a készülék. A készülék használata után bontsa a hálózati csatlakozását.

Tisztítás

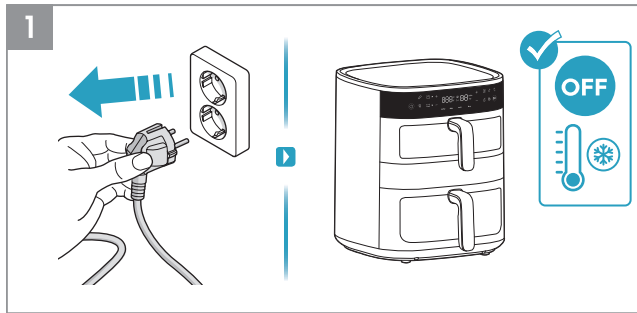

1. Mindig bontsa a készülék hálózati csatlakozását, és a tisztítás előtt várja meg, amíg az lehül.
2. Egy puha kendővel törölje le a készülék külsejét.

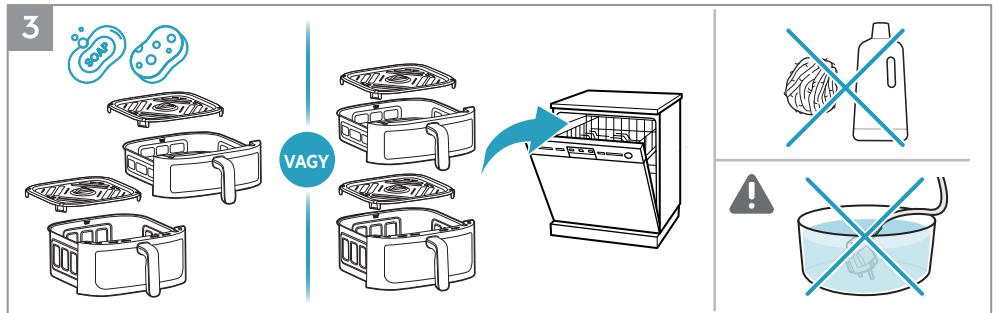

3. Meleg mosogatószeres vízzel tisztítsa meg a serpenyőt és a rácsot vagy tegye azokat mosogatógépbe.

▲MEGJEGYZÉS: Kerülje a dörzsölő tisztítószeres vagy fémeszközök használatát, hogy védje a letapadástól mentes bevonatot.



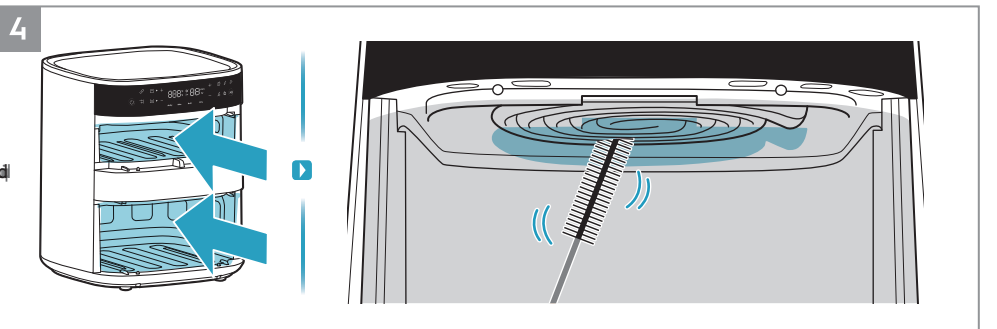



































VIGYÁZAT: Sohase merítse a készüléket, a kábelt vagy a csatlakozódugót vízbe vagy bármilyen más folyadékba.



4. Egy tisztítókefével tisztítsa meg a fűtőelemeket.

MEGJEGYZÉS: A fűtőelemek tisztítása előtt biztosítsa, hogy teljesen lehűljön a készülék.

Sütési útmutató

							
AirFry	7mm/10mm 	4L 	400g	180 °C	18perc		
		7L 	400g	180 °C	18perc		
AirFry		4L 	400g	170 °C	8perc		
		7L 	400g	170 °C	10perc		
AirFry		4L 	400g/2pcs	140 °C	15perc		
		7L 	400g/2db	140 °C	15perc		
AirFry		4L 	1000g/8db	180 °C	28perc		
		7L 	1000g/8db	180 °C	28perc		
AirFry		4L 	400g/2db	200 °C	10perc		
		7L 	400g/2db	200 °C	10perc		
AirFry		4L 	220g/6hüvelyk	160 °C	12perc		
		7L 	220g/6hüvelyk	160 °C	14perc		

GB

BG

DE

ES

FR

GR

IT

PT

NL

CA

SE























FI

DK

NO

HU

AR

Recipe							
AirFry		 7L	1200g	180 °C	55perc		
AirFry		 7L	400g/9db	160 °C	20perc		
Grill		 4L	180g/4db	180 °C	8perc		
		 7L	180g/4db	180 °C	9perc		
Dry		 4L	180g	80 °C	3óra		
		 7L	180g	80 °C	3óra		
Dry		 4L	200g	80 °C	3óra		
		 7L	200g	80 °C	3óra		

EN
BG
DE
ES
FR
GR
IT
PT
NL
CA
SE
FI
DK
NO
HU
AR

A teendő, ha...

Probléma	Ellenőrizze, hogy...
Nem tudja bekapcsolni vagy működtetni a készüléket.	<ul style="list-style-type: none">• Megfelelően van csatlakoztatva a készülék egy hálózati csatlakozóaljzathoz.• Helyesen vannak a kosarak a készülékbe rakva. A feszültségellátás biztosítása érdekében ügyeljen arra, hogy teljesen be legyenek nyomva a készülékbe.• Be van állítva a sütési idő.
Nem tudta betolni a kosarat a készülékbe.	<ul style="list-style-type: none">• A kosár maximális befogadóképességénél több van betöltve.• Helyesen van betéve a kosár. Kattanást kell hallania, amikor beteszi az egységbe.• Egy tárgy van a kosár alatt, ami akadályozza a megfelelő zárását.
Fehér füst száll ki a készülékből.	<ul style="list-style-type: none">• Túl zsíros a készíttendő étel.• Tiszta a kosár, rács és a fűtőelem.
E1 kijelzés látható a kijelzőn.	<ul style="list-style-type: none">• Felső kosárnál szakadás van.
E2 kijelzés látható a kijelzőn.	<ul style="list-style-type: none">• Felső kosárnál zárlat van.
E3 kijelzés látható a kijelzőn.	<ul style="list-style-type: none">• Alsó kosárnál szakadás van.
E4 kijelzés látható a kijelzőn.	<ul style="list-style-type: none">• Alsó kosárnál zárlat van.
E5 kijelzés látható a kijelzőn.	<ul style="list-style-type: none">• Kezelőszerv PCBA kommunikációs hiba.
E6 kijelzés látható a kijelzőn.	<ul style="list-style-type: none">• Tápellátás PCBA kommunikációs hiba.

* Ha hibakód jelenik meg a kijelzőn, akkor egy szervizben kell megjavíttatni a készüléket.

Műszaki adatok

Termék	Forrólevegős sütő
Modell	AAFD11B
Feszültség (V~)	220 V ~ 240 V
Teljesítmény (W)	2700 W
Frekvencia (Hz)	50 ~ 60 Hz
Befogadóképesség	4 l + 7 l

GB

BG

DE

ES

FR

GR

IT

PT

NL

CA

SE

FI

DK

NO

HU

AR



Electrolux

كٲب ال؁ل؁مات

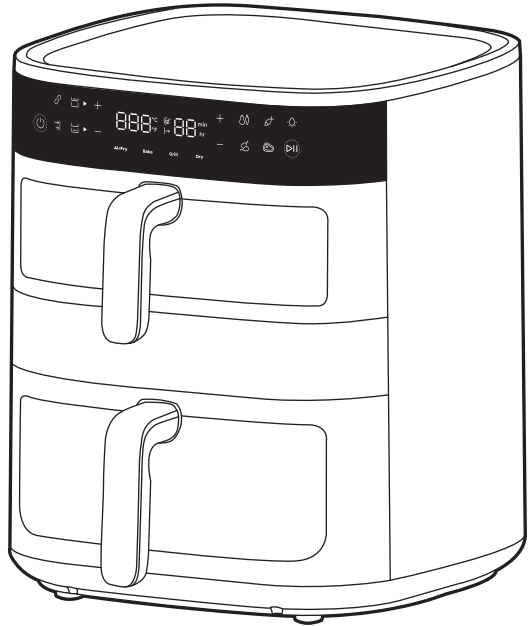

مقلاة هوائية مزدوجة 800

نظرة عامة

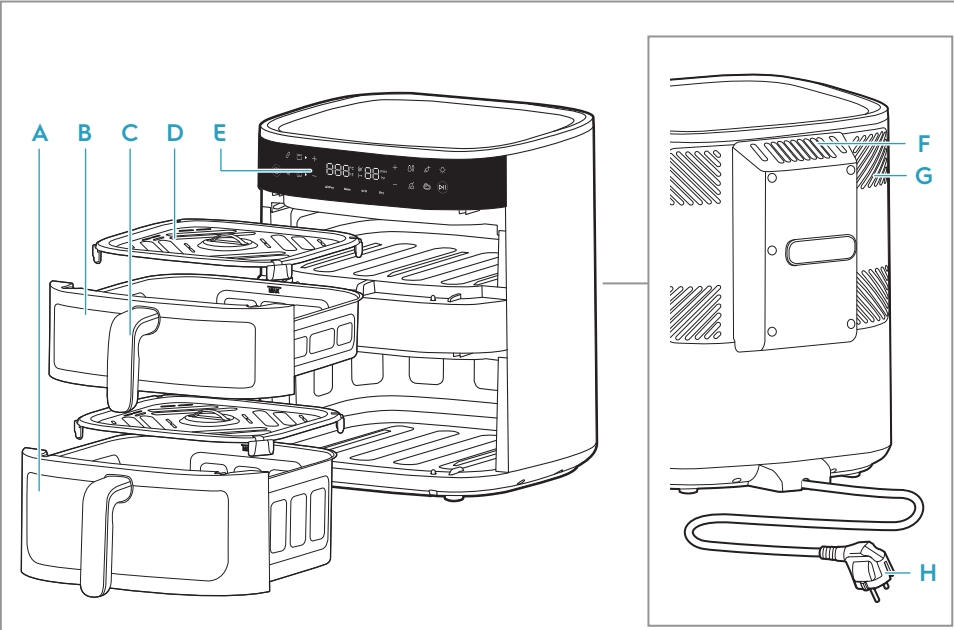

- A السلة السفلية (7 لتر) C مقبض السلة E لوحة التحكم G نظام التبريد
 B السلة العلوية (4 لتر) D شبكة F مخرج الهواء H سلك الطاقة الرئيسي

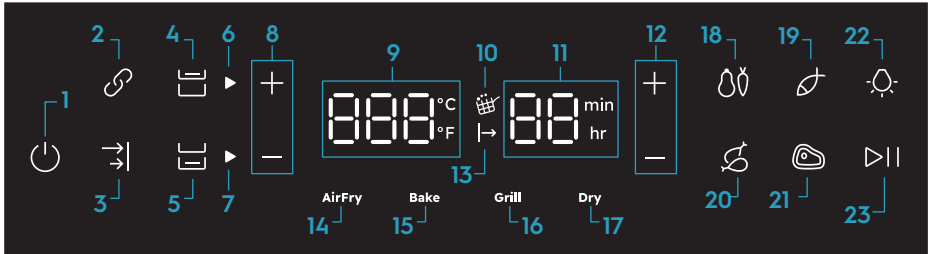

1. تشغيل/إيقاف
2. وظيفة الربط
3. وظيفة الإنهاء المتزامن
4. التحكم في السلة العلوية
5. التحكم في السلة العلوية
6. مؤشر السلة العلوية
7. مؤشر السلة السفلية
8. التحكم في درجة الحرارة
9. مؤشر درجة الحرارة (درجة مئوية 200-40)
10. تنكير بالهز
11. مؤشر الوقت القلي الهوائي: 1-99 دقيقة، (التجفيف: 1-5 ساعات)
12. التحكم في الوقت
13. الانتظار لبدء الطهي
14. وظيفة القلي الهوائي
15. وظيفة الخبز
16. وظيفة الشواء
17. وظيفة التجفيف
18. الخضراوات
19. الأسماك
20. الدجاج
21. شرائح اللحم
22. التحكم في الإضاءة
23. تشغيل/إيقاف مؤقت

قبل الاستخدام الأول

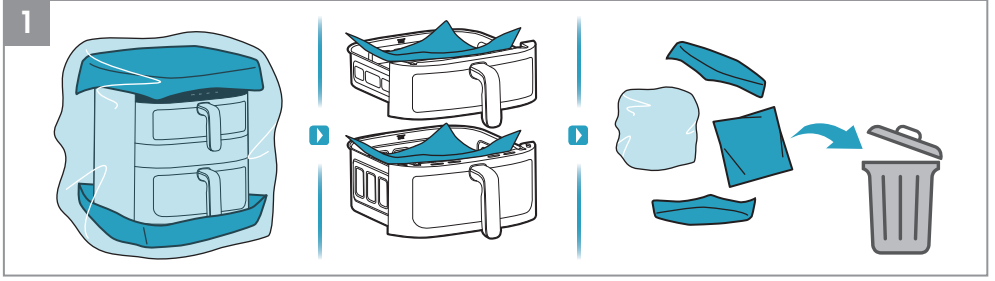

1. قم بإزالة جميع مواد التغليف والحماية.

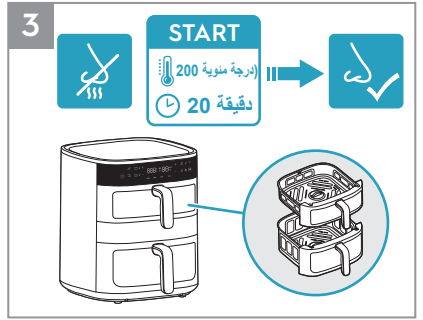
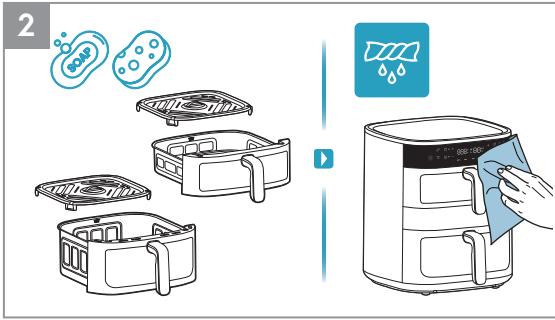

2. نظف المقلاة والشبكة بالماء الدافئ وسائل غسل الصحون. امسح داخل الجهاز وخارجه بقطعة قماش ناعمة.

3. من الطبيعي أن تتبعث روائح من الوحدة الجديدة في المرات القليلة الأولى التي يتم تشغيلها فيها. قم بتشغيل المقلاة الهوائية الفارغة على درجة حرارة 200 درجة مئوية لمدة 20 دقيقة قبل الاستخدام الأول لتجنب ذلك.



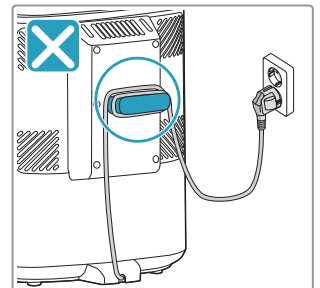
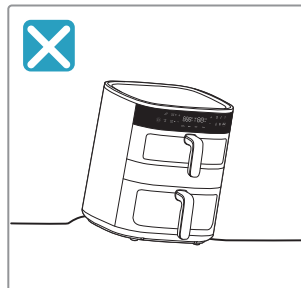
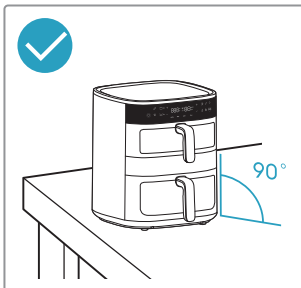
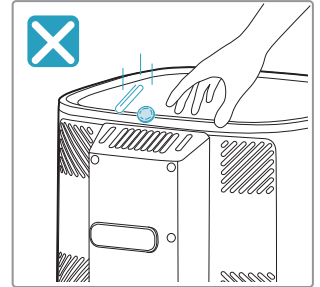
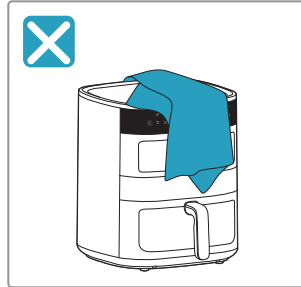
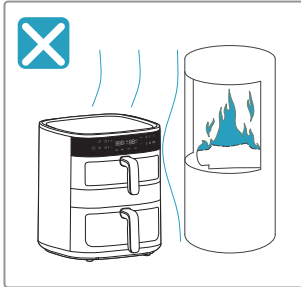



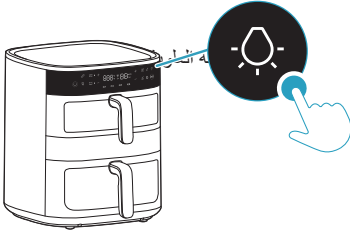
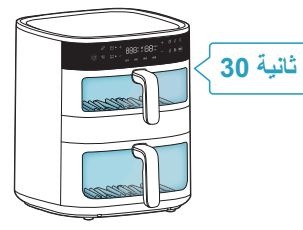
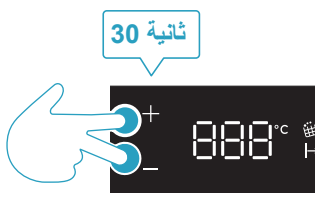
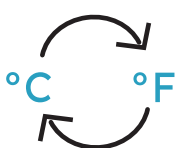



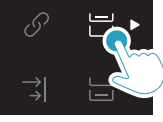
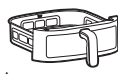
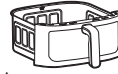

احتياطات السلامة









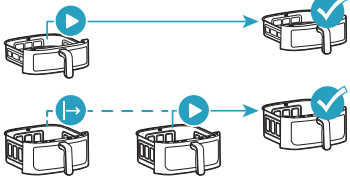



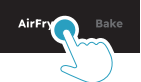



التحكم في الإضاءة وتحويل مقياس درجة الحرارة

 <p>التحكم في الإضاءة</p>		
<p>°C/°F</p> <p>تحويل مقياس درجة الحرارة</p>		

اختيار السلة

	 <p>4 لتر</p>	 <p>7 لتر</p>	
 <p>السلة العلوية</p>			
 <p>السلة السفلية</p>			
 <p>وظيفة الربط</p>			
 <p>وظيفة الإنهاء المتزامن</p>			

وظائف مُعدة مسبقًا

					
AirFry	180 درجة مئوية	15 دقيقة	200~60 درجة مئوية	99~1 دقيقة	
	170 درجة مئوية	10 دقيقة	200~60 درجة مئوية	99~1 دقيقة	
	140 درجة مئوية	15 دقيقة	200~60 درجة مئوية	99~1 دقيقة	
	180 درجة مئوية	30 دقيقة	200~60 درجة مئوية	99~1 دقيقة	
	220 درجة مئوية	10 دقيقة	200~60 درجة مئوية	99~1 دقيقة	
Bake	170 درجة مئوية	15 دقيقة	200~60 درجة مئوية	99~1 دقيقة	
Grill	200 درجة مئوية	5 دقيقة	200~60 درجة مئوية	99~1 دقيقة	
Dry	80 درجة مئوية	5 ساعات	200~60 درجة مئوية	1~5 ساعات	

GB
BG
DE
ES
FR
GR
IT
PT
NL
CA
SE
FI
DK
NO
HU
AR

قبل الطهي

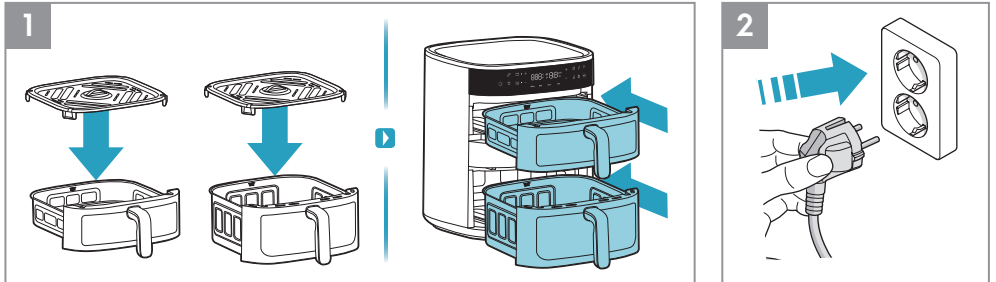

- قبل كل عملية طهي، يرجى وضع الشبكة في السلة (لا يلزم إزالة وسادة السيليكون المقاومة للحرارة الخاصة بالشبكة)، ودفع السلة بالكامل داخل الجهاز.
- ادخل قابس الطاقة في مأخذ الطاقة.

طريقة الاستخدام - سلة واحدة

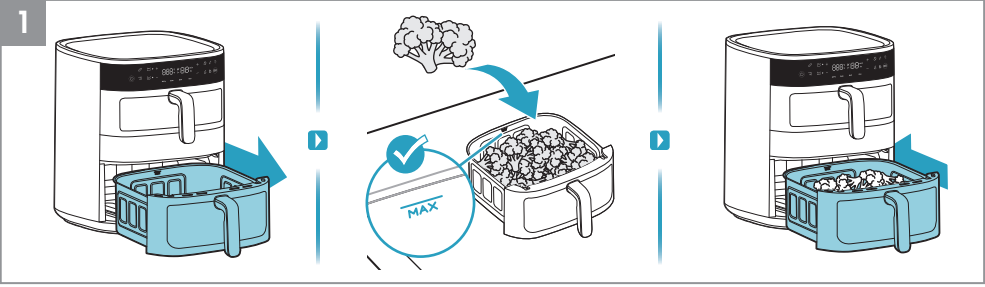

1. اسحب سلة واحدة وضعها على سطح ثابت، وضع الطعام في السلة، مع مراعاة مؤشر السعة القصوى. ثم ادفع السلة التي تحتوي على الطعام بالكامل إلى داخل الجهاز.



2. اضغط على زر التشغيل/الإيقاف. اختر أولاً السلة التي بها الطعام. ثم اختر طريقة الطهي التي ترغب بها، على سبيل المثال، وظيفة القلي الهوائي. اضبط الوقت ودرجة الحرارة حسب ذوقك أو اختر إحدى الوصفات المعدة مسبقاً، على سبيل المثال، الخضروات. وأخيراً، اضغط على زر تشغيل/إيقاف مؤقت.

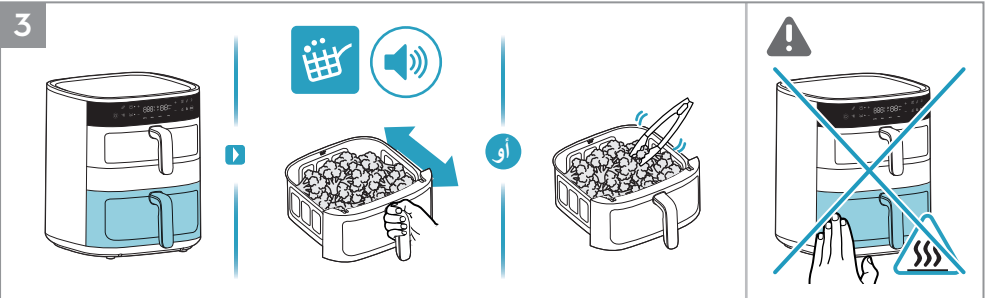

3. عندما يضيء رمز "التذكير بالهز" ويصدر صوت تنبيه أثناء عملية الطهي، استخدم أدوات مقاومة للحرارة لقلب الطعام مرة واحدة أو قم بهز الطعام برفق في سلة القلي قليلاً.

⚠ تنبيه : لا تهز سلة القلي بقوة لتجنب تناثر الطعام والتسبب في الحروق .

⚠ تنبيه : توخ الحذر من الأسطح الساخنة عند استخدام الجهاز .

تذكير بالهز

يتم تفعيل خاصية "التذكير بالهز" أثناء وظيفة القلي الهوائي والوصفات المعدة مسبقاً، مثل الخضراوات والأسماك وأفخاذ الدجاج وشرايح اللحم .

عندما يحين وقت هز أو قلب طعامك، سيضيء رمز "تذكير بالهز" ويومض لمدة دقيقة واحدة، بينما سينتكر صوت التنبيه ثلاث مرات .

إن خاصية "التذكير بالهز" ليست إلزامية، وبالتالي سيستمر الطهي كالمعتاد حتى لو لم يتم قلب الطعام أو هزه .

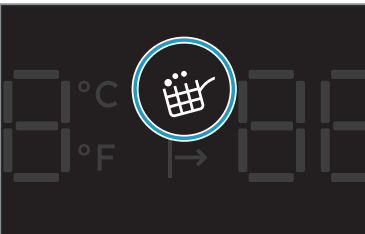

GB
BG
DE
ES
FR
GR
IT
PT
NL
CA
SE
FI
DK
NO
HU

AR

4



3. في نهاية وقت الطهي، سيصدر الجهاز إشارة صوتية. قم بإزالة السلة بعناية وضعها على سطح مقاوم للحرارة. افصل الجهاز عن الكهرباء عند استخدامه.

⚠ تنبيه: قد يخرج البخار الساخن من السلة عند فتحها في منتصف عملية الطهي أو في نهايتها. تأكد من إبعاد وجهك وذراعك ويدك عن البخار عند فتحها.

طريقة الاستخدام - السلة العلوية + السلة السفلية

1

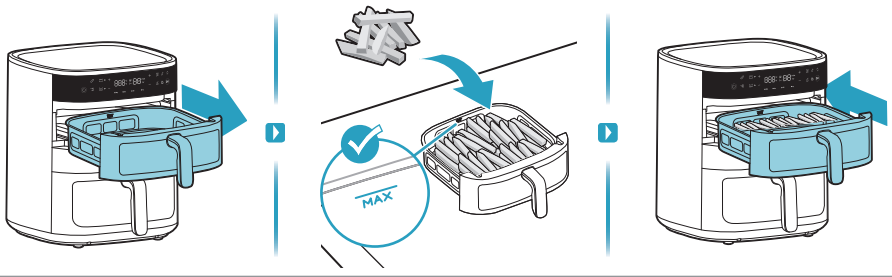

1. أولاً، اسحب السلة العلوية وضع الطعام فيها، على سبيل المثال، البطاطس المقلية.

2

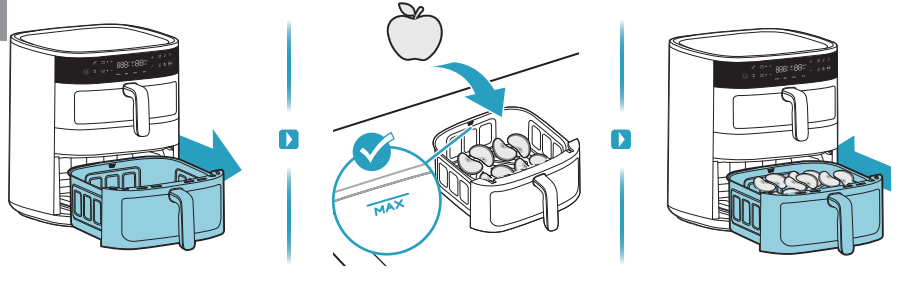

2. ثانيًا، اسحب السلة السفلية وضع الطعام فيها، على سبيل المثال شرائح التفاح.

3



3. اضغط على زر التشغيل/الإيقاف. اختر السلة العلوية أولاً. ثم اختر طريقة الطهي التي ترغب بها، على سبيل المثال، وظيفة القلي الهوائي. اضبط الوقت ودرجة الحرارة حسب ذوقك أو اختر إحدى الوصفات المعدة مسبقًا، على سبيل المثال، الخضروات. وأخيرًا، اضغط على زر تشغيل/إيقاف مؤقت.



4. ثانيًا، اختر السلة السفلية. ثم اختر طريقة الطهي التي ترغب بها، على سبيل المثال، وظيفة القلي التجفيف. اضبط الوقت ودرجة الحرارة حسب ذوقك. وأخيرًا، اضغط على زر تشغيل/إيقاف مؤقت.

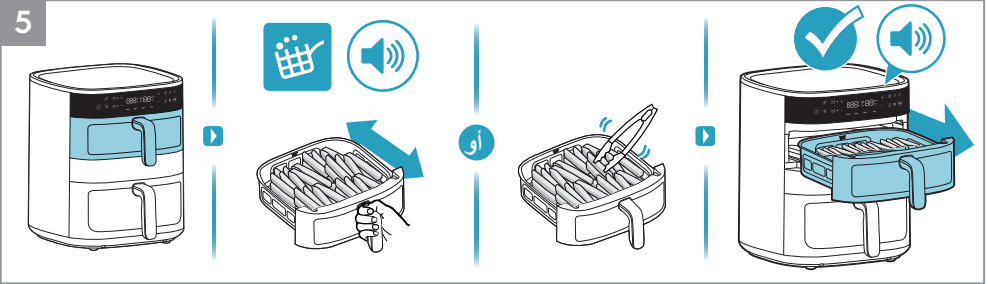

5. عندما يضيء رمز "التذكير بالهز" ويصدر صوت تنبيه أثناء عملية الطهي، استخدم أدوات مقاومة للحرارة لقلب الطعام مرة واحدة أو قم بهز الطعام برفق في سلة القلي قليلاً. في نهاية وقت الطهي في السلة العلوية، سيصدر الجهاز إشارة صوتية.

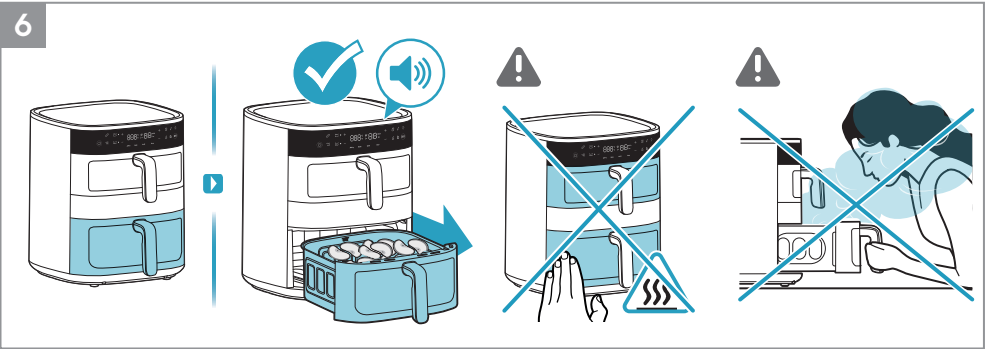

6. في نهاية وقت الطهي في السلة السفلية، سيصدر الجهاز إشارة صوتية.

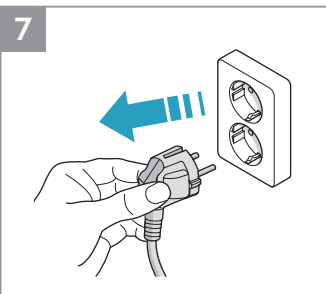

7. افصل الجهاز عن الكهرباء بعد استخدامه.

طريقة الاستخدام - وظيفة الربط

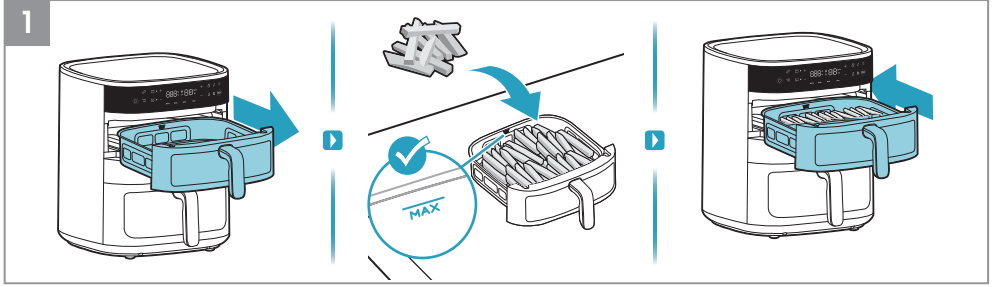

1. أولاً، اسحب السلة العلوية وضع الطعام فيها، على سبيل المثال، البطاطس المقلية.

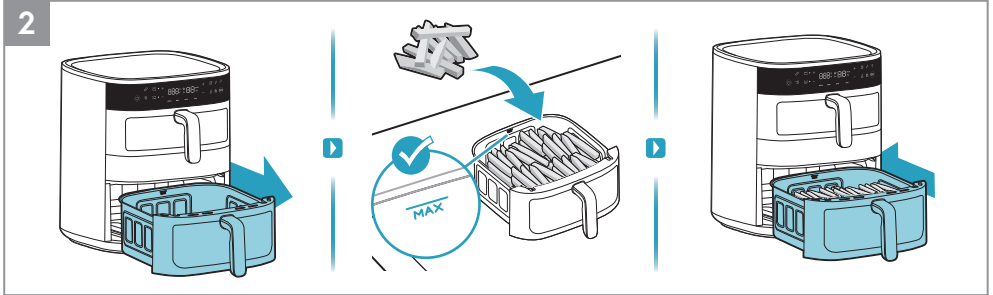

2. ثانيًا، اسحب السلة السفلية وضع الطعام فيها، على سبيل المثال البطاطس المقلية .



3. اضغط على زر التشغيل/الإيقاف. اختر أولاً وظيفة الربط. ثم اختر طريقة الطهي التي ترغب بها، على سبيل المثال، وظيفة القلي الهوائي. اضبط الوقت ودرجة الحرارة حسب نوبك أو اختر إحدى الوصفات المُعدة مسبقًا. وأخيرًا، اضغط على زر تشغيل/إيقاف مؤقت .

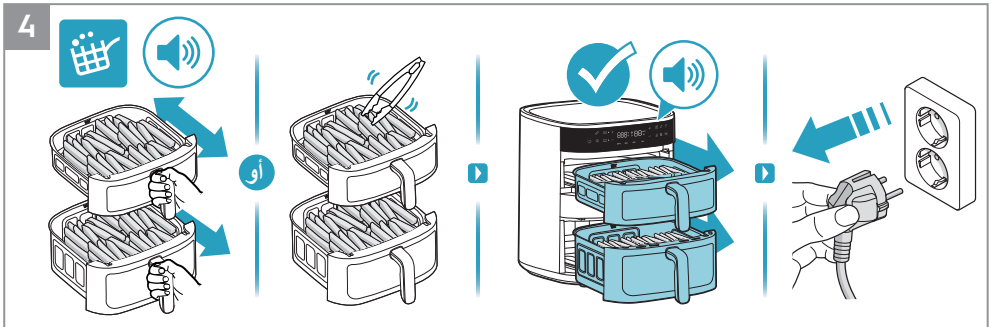

4. عندما يضيء رمز "التذكير بالهز" ويصدر صوت تنبيه أثناء عملية الطهي، استخدم أدوات مقاومة للحرارة لقلب الطعام مرة واحدة أو قم بهز الطعام برفق في سلة القلي قليلاً. في نهاية وقت الطهي، سيصدر الجهاز إشارة صوتية. أفضل الجهاز عن الكهرباء بعد استخدامه .

طريقة الاستخدام - وظيفة الإنهاء المتزامن

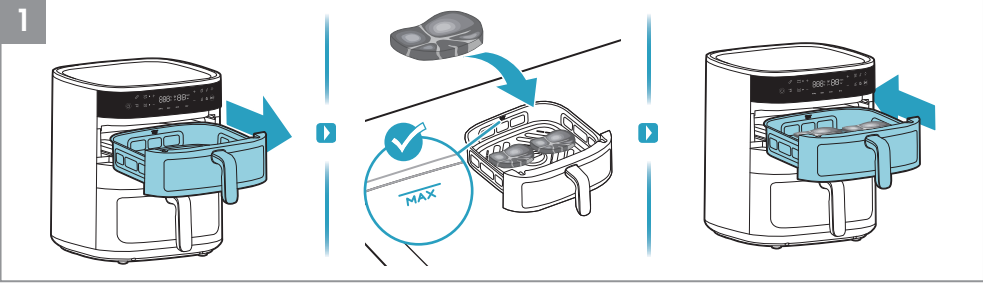

1. أولاً، اسحب السلة العلوية وضع الطعام فيها، على سبيل المثال، شرائح اللحم .

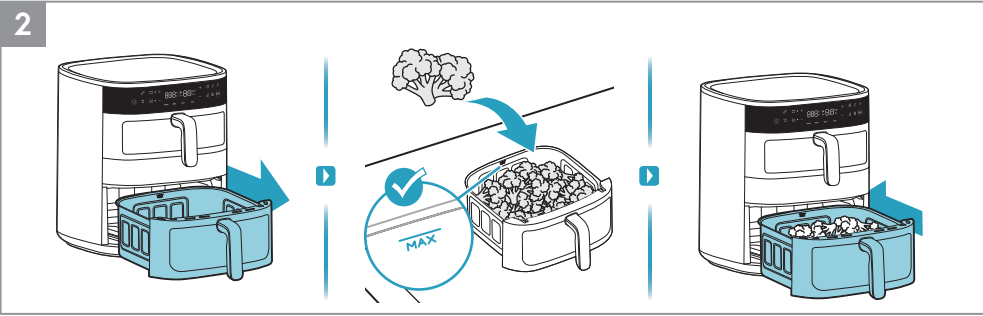

2. ثانيًا، اسحب السلة السفلية وضع الطعام فيها، على سبيل المثال، البروكلي .



3. اضغط على زر التشغيل/الإيقاف. اختر وظيفة الإنهاء المتزامن. أولاً، اختر السلة العلوية، ثم اختر طريقة الطهي التي ترغب بها، على سبيل المثال، وظيفة القلي الهوائي. اضبط الوقت ودرجة الحرارة حسب ذوقك أو اختر إحدى الوصفات المعدة مسبقًا، على سبيل المثال، شرائح اللحم .

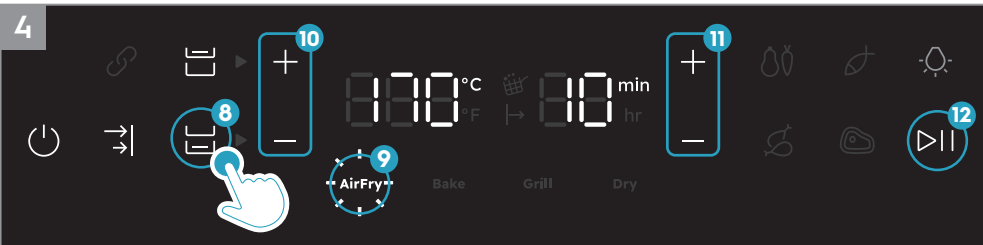

4. ثم اختر السلة السفلية، واختر طريقة الطهي التي ترغب بها، على سبيل المثال، وظيفة القلي الهوائي. اضبط الوقت ودرجة الحرارة حسب ذوقك أو اختر إحدى الوصفات المعدة مسبقًا. وأخيرًا، اضغط على زر تشغيل/إيقاف مؤقت .

5

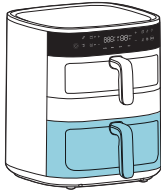

أو



5. أولاً، سيتم إعطاء الأولوية للسلة السفلية ذات وقت الإعداد الأطول في الطهي. عندما يضيء رمز "التذكير بالهز" ويصدر صوت تنبيه أثناء عملية الطهي، استخدم أدوات مقاومة للحرارة لقلب الطعام مرة واحدة أو قم بهز الطعام برفق في سلة القلي قليلاً.

6

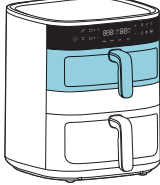

أو

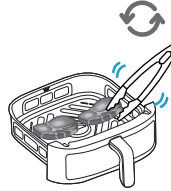

6. ثانيًا، ستبدأ السلة العلوية ذات وقت الإعداد الأقصر في الطهي. عندما يضيء رمز "التذكير بالهز" ويصدر صوت تنبيه أثناء عملية الطهي، استخدم أدوات مقاومة للحرارة لقلب الطعام مرة واحدة أو قم بهز الطعام برفق في سلة القلي قليلاً.

مؤشر الانتظار لبدء الطهي

عند تفعيل "وظيفة الإنهاء المتزامن"، ستنظر السلة ذات وقت الطهي الأقصر حتى تنتهي السلة ذات وقت الطهي الأطول من الطهي لفترة من الوقت، بحيث يمكن لكلتا السلتين إنهاء الطهي في نفس الوقت. خلال هذه الفترة، سيضيء "مؤشر الانتظار لبدء الطهي" حتى يبدأ الطهي.

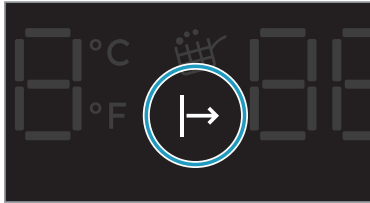

7

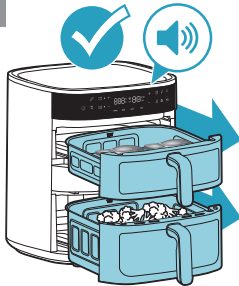

▶

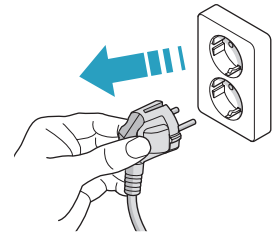

7. في نهاية وقت الطهي، سيصدر الجهاز إشارة صوتية. افصل الجهاز عن الكهرباء بعد استخدامه.

التنظيف

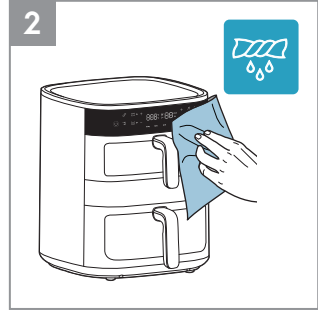
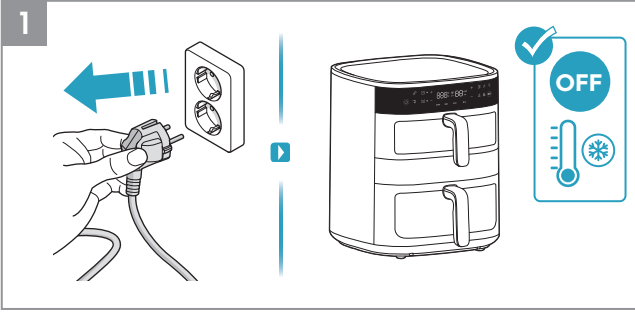

1. افصل الجهاز دائماً عن الكهرباء وانتظر حتى يبرد قبل تنظيفه.
2. امسح الجزء الخارجي من الجهاز بقطعة قماش ناعمة .

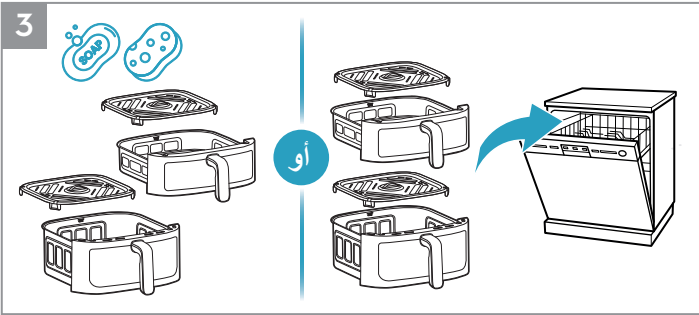

3. نظف المقلاة والشبكة بالماء الدافئ وسائل غسل الصحون، أو ضعهما في غسالة الصحون .

⚠ ملحوظة : تجنب استخدام منتجات التنظيف الكاشطة أو الأدوات المعدنية لحماية الطبقة غير اللاصقة .



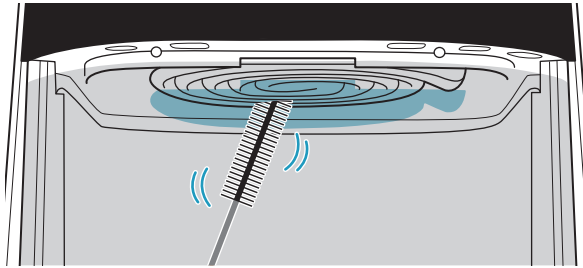
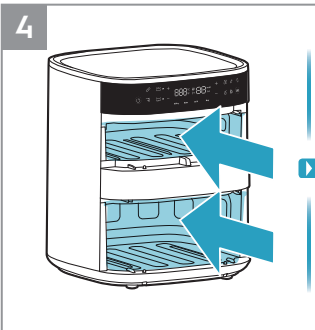









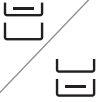

























تنبيه : لا تقم أبداً بغمر المنتج أو السلك أو القابس في الماء أو أي سائل آخر .

























4. نظف عنصر التسخين بفرشاة تنظيف .

ملحوظة : تأكد من الجهاز قد برد تماماً قبل تنظيف عنصر التسخين .

التنظيف

							
AirFry	7mm/10mm 	 4 لتر	400 غرام	180 درجة مئوية	18 دقيقة		
		 7 لتر	400 غرام	180 درجة مئوية	18 دقيقة		
AirFry		 4 لتر	400 غرام	170 درجة مئوية	8 دقيقة		
		 7 لتر	400 غرام	170 درجة مئوية	10 دقيقة		
AirFry		 4 لتر	400 غرام/قطعتين	140 درجة مئوية	15 دقيقة		
		 7 لتر	400 غرام/قطعتين	140 درجة مئوية	15 دقيقة		
AirFry		 4 لتر	1000g/8pcs	180 درجة مئوية	28 دقيقة		
		 7 لتر	1000g/8pcs	180 درجة مئوية	28 دقيقة		
AirFry		 4 لتر	400 غرام/قطعتين	200 درجة مئوية	10 دقيقة		
		 7 لتر	400 غرام/قطعتين	200 درجة مئوية	10 دقيقة		
AirFry		 4 لتر	220 غرام/6 بوصة	160 درجة مئوية	12 دقيقة		
		 7 لتر	220 غرام/6 بوصة	160 درجة مئوية	14 دقيقة		

GB
BG
DE
ES
FR
GR
IT
PT
NL
CA
SE
FI
DK
NO
HU
AR

Recipe							
AirFry		 7 لتر	1200 غرام	180 درجة مئوية	55 دقيقة		
Bake		 4 لتر	400g/9pcs	160 درجة مئوية	20 دقيقة		
Grill		 4 لتر	180g/4pcs	180 درجة مئوية	8 دقيقة		
		 7 لتر	180g/4pcs	180 درجة مئوية	9 دقيقة		
Dry		 4 لتر	180 غرام	80 درجة مئوية	3 ساعات		
		 7 لتر	180 غرام	80 درجة مئوية	3 ساعات		
Dry		 4 لتر	200 غرام	80 درجة مئوية	3 ساعات		
		 7 لتر	200 غرام	80 درجة مئوية	3 ساعات		

ما الذي يجب فعله في الحالات التالية ...

المشكلة	تحقق ما إذا كان ...
لا يمكنك تفعيل الجهاز أو تشغيله .	<ul style="list-style-type: none"> • الجهاز موصل بشكل صحيح بمصدر الطاقة الكهربائية . • السلال في الوضع الصحيح . تأكد من إدخالها بالكامل في الجهاز لتفعيل التيار الكهربائي . • تم ضبط وقت الطهي .
لا يمكنك إدخال السلة في الجهاز .	<ul style="list-style-type: none"> • تم ملء السلة بما يتجاوز سعتها القصوى . • تم وضع السلة بشكل صحيح . يجب أن يصدر صوت طقطقة عند وضعه في الوحدة . • يوجد جسم أسفل السلة يعيق إغلاقها بشكل صحيح .
يخرج دخان أبيض من الجهاز .	<ul style="list-style-type: none"> • الطعام الذي تعده دهني للغاية . • السلة والشبكة وعنصر التسخين نظيفة .
E1 تعرض الشاشة .	• الدائرة الكهربائية للسلة العلوية مفتوحة .
E2 تعرض الشاشة .	• دائرة قصر للسلة العلوية .
E3 تعرض الشاشة .	• الدائرة الكهربائية للسلة السفلية مفتوحة .
E4 تعرض الشاشة .	• دائرة قصر للسلة السفلية .
E5 تعرض الشاشة .	• فشل في الاتصال بمجموعة لوحة الدوائر المطبوعة للتحكم .
E6 تعرض الشاشة .	• فشل الاتصال بمجموعة لوحة الدوائر المطبوعة للطاقة .

* في حال ظهور رموز خطأ على الشاشة، يجب إصلاح الجهاز بواسطة مركز خدمة معتمد .

البيانات الفنية

المنتج	مقلاة هوائية
رقم الموديل	AAFD11B
الجهد (فولت ~)	220 فولت ~ 240 فولت
الطاقة (واط)	2700 واط
التردد (هرتز)	50 ~ 60 Hz
السعة	4 لتر + 7 لتر

